



Installation and Maintenance Manual
CTC EcoLogic XL/L/M II
Control unit
Model XL/L/M
400V 3N~/ 230V 1N~



Translation of the original instructions.
Keep for future use.
Read carefully before use.

Table of contents

1.	Congratulations on buying your new product!	3	10.	Operation and Maintenance	100
2.	Safety instructions	5	11.	Troubleshooting	101
3.	Important to consider!	6	11.1	Information messages.....	103
4.	Design and function of CTC EcoLogic	7	11.2	Alarm messages.....	104
4.1	Main components.....	7	11.3	Critical alarms - Risk of freezing	106
4.3	Scope of delivery.....	9	12.	Pipe installation	107
4.2	Heating circuit.....	9	12.1	System type 1*	107
4.4	DHW.....	11	12.2	System types 2 and 3*	110
4.5	Additional heat	11	12.3	System types 4 and 5*	115
4.7	Solar collectors*	12	12.4	System type 6*	120
4.6	Pool*	12	13.	Valves	124
4.8	Recharging borehole/ground*	13	13.1	Three-way mixing valve.....	124
4.9	Free cooling*	13	13.2	3-way valves	125
4.10	Active cooling*.....	13	13.3	Bivalent mixing valve.....	126
5.	House heating settings	18	14.	Electrical installation	127
6.	Technical data	21	14.1	High voltage	127
7.	Display settings	22	14.2	Communication between CTC EcoLogic and CTC EcoAir/CTC EcoPart.....	127
7.1	Start page	22	14.3	Protection – low voltage (sensor)	131
7.2	Installation wizard.....	23	15.	Wiring diagram	134
7.3	Heating/Cooling	24	15.1	Relay board A2.....	134
7.4	DHW.....	27	15.2	Expansion board A3	135
7.5	Ventilation.....	28	15.3	I/O board A7.....	136
7.6	Schedule	29	15.4	Connection table for electrical components.....	137
7.7	Operation data	31	15.5	Resistances for sensors.....	141
8.	Advanced	45	16.	Installation, Communication	142
8.1	Display	45	16.1	Remote - Screen Mirroring	143
8.2	Settings	47	16.2	myUplink.....	144
8.3	Define	74	17.	First start	145
8.4	Cascade connection	84			
8.5	Service	91			
9.	Parameter list CTC EcoLogic XL/L/M	97			

Software update



software.ctc.se

EN

For more information on updated functions and downloading the latest software, see the website "software.ctc.se".

1. Congratulations on buying your new product!



You have just purchased a CTC EcoLogic, which we hope you will be very pleased with. On the following pages, you can read about how to maintain your CTC EcoLogic. One part contains general information for the property owner etc. and one part has been written for the installer. Save this manual containing the installation and maintenance instructions. You will enjoy your CTC EcoLogic for many years to come, and this is where you will find the information you need.

CTC EcoLogic is available in three different designs:

- CTC EcoLogic XL
- CTC EcoLogic L
- CTC EcoLogic M

CTC EcoLogic XL has more features than CTC EcoLogic L, and CTC EcoLogic L has more features than CTC EcoLogic M. These are marked with */** in the Installation and Maintenance Manual.

CTC EcoLogic L and CTC EcoLogic M can easily be upgraded by installing extension board and/or I/O board.

The Complete System

CTC EcoLogic is a complete system that meets your home's heating and hot water requirements. It is equipped with a unique control system that monitors and controls your entire heating circuit regardless of how you choose to tailor it.

CTC EcoLogic has a control system that:

- monitors all DHW and heating circuit functions;
- monitors and controls your heat pump, solar collectors*, additional heat, buffer tank, pool*, etc.;
- allows for individual settings;
- indicates desired values, for instance, temperatures and energy consumption;
- facilitates settings in a simple and structured manner.

Service-friendly, second to none

Easily accessible electrical components, along with effective troubleshooting functions in the control program, make the CTC EcoLogic easy to service. It is supplied with a room sensor as standard, which is equipped with LED lights that flash in the event of a fault. CTC EcoLogic is fully equipped to work with the CTC EcoAir outdoor air heat pump, the CTC EcoPart ground source heat pump, solar collectors* and an external boiler where present. CTC EcoLogic can control a number of combinations to give you an extremely flexible, eco-friendly and energy-saving heating system.

* Applies to CTC EcoLogic XL/L.

Cyber security UK

This information extends to England, Wales, Scotland and Northern Ireland.

CTC AB meets the applicable security requirement in Schedule 1 according to The Product Security and Telecommunications

Infrastructure (Security Requirements for Relevant Connectable Products) Regulations 2023.

The defined support period in terms of security update is three years from the date of manufacture.

The date of manufacturer is found in the serial number, placed on the product.

xxxxYYWWxxxx

YY = Year

WW = Week

If a suspected software security issue or flaw has been discovered,

scan the QR code to get to the reporting page or visit <https://ctc-heating.com/cyber-security> to report.



2. Safety instructions



The installation should be preceded by an omnipolar safety switch according to overvoltage category III, which ensures disconnection from all electric power sources.

Turn off the power with an omnipolar switch before doing any work on the product.



The product must be connected to protective earth.



The product is classified as IP X1. The product must not be rinsed with water.

The product must not be started if it is not filled with water; instructions are in the "Pipe installation" section.



Never jeopardise safety by removing bolted covers, hoods or similar.

If these instructions are not followed when installing, operating and maintaining the system, CTC's commitment under the applicable warranty terms is not binding.



Service of the product's electrical system must only be carried out by a qualified electrician in compliance with the specific requirements of the national standard for electrical safety.

Replacement of damaged supply cable, must be carried out by the manufacturer or qualified service engineer to avoid risk.

This device can be used by children from the age of eight years and above and by people with reduced physical, sensory or mental ability or lack of experience or knowledge if they have been taught, either with supervision or with the instructions provided, how to use the device safely and understand the risks involved. Children should not play with the device. Cleaning and maintenance should not be carried out by children without supervision.

3. Important to consider!

Check the following points in particular at the time of delivery and installation:

- Remove the packaging and check that the product (electrical connection box and display) has not been damaged in transit. Report any transport damage directly to the carrier.
- Check for missing parts.
- The product must not be installed where the ambient temperature is higher than 60 °C.
- To control CTC EcoPart 600M, CTC EcoLogic must have software version 20190620 or later.
- Register your product for warranty and insurance via the website <https://www.ctc-heating.com/customer-service#warranty-registration>
- Click the "i button" in the lower right corner of the screen in the "Advanced" menu, this displays the product's serial number.
- Click on "Heat pump" on the main menu page for "Operation data" to see "Software version HP PCB".

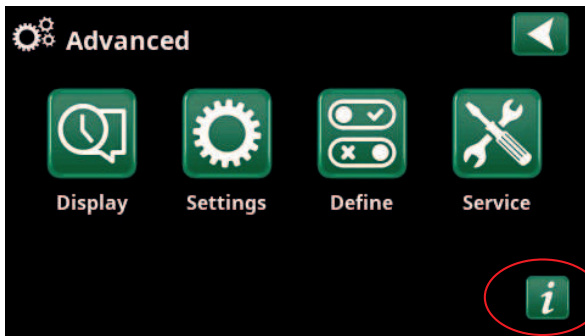
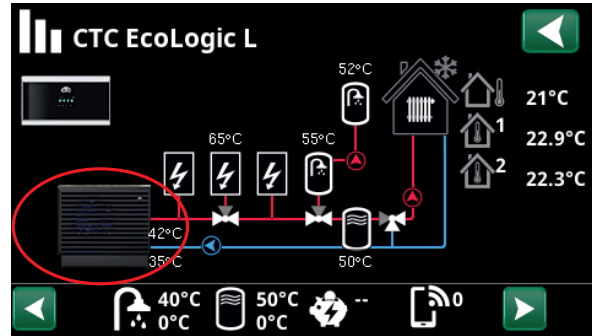

! If these instructions are not followed during the installation, operation and maintenance of the system, CTC's liability under the applicable warranty terms is not binding.

i Information in this type of box [i] is intended to help ensure that the product functions optimally.

! i Information in this type of box [!i] is particularly important for correctly installing and using the product.

Fill in the information below. It may come in useful if anything should happen.

Product:	Serial number:
Installer:	Name:
Date:	Tel. no.:
Electrical installer:	Name:
Date:	Tel. no.:

No liability is accepted for any misprints. We reserve the right to make design changes.

4. Design and function of CTC EcoLogic

This chapter describes the main components as well as the subsystems, which, in different configurations, form part of the six main systems (System Types 1 to 6). For more information about System Types 1 to 6, refer to the "Pipe Installation" chapter.

4.1 Main components

4.1.1 Printed circuit board (PCB)

The images below show important components when connecting the CTC EcoLogic.

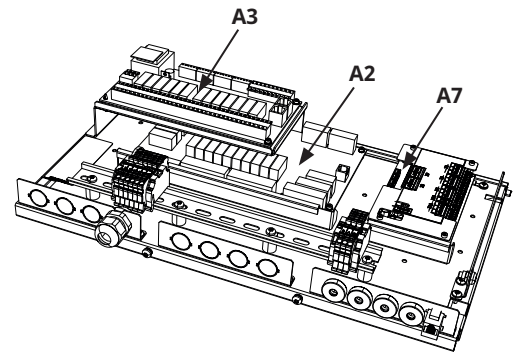

Relay board (A2)

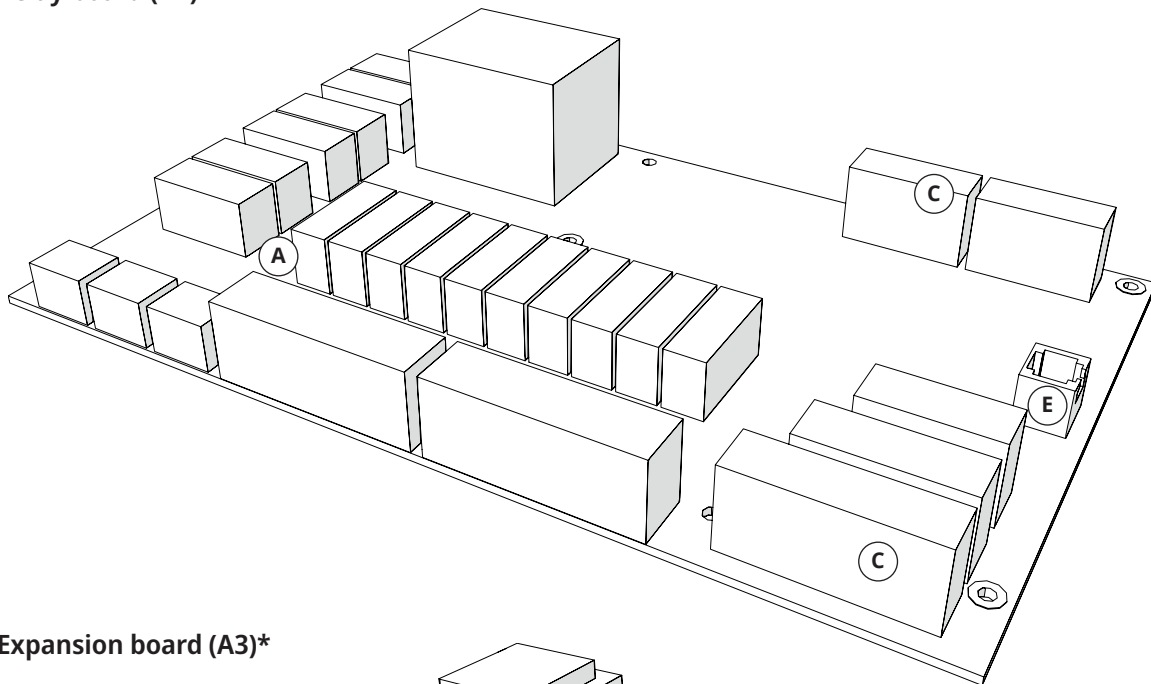

Expansion board (A3)*

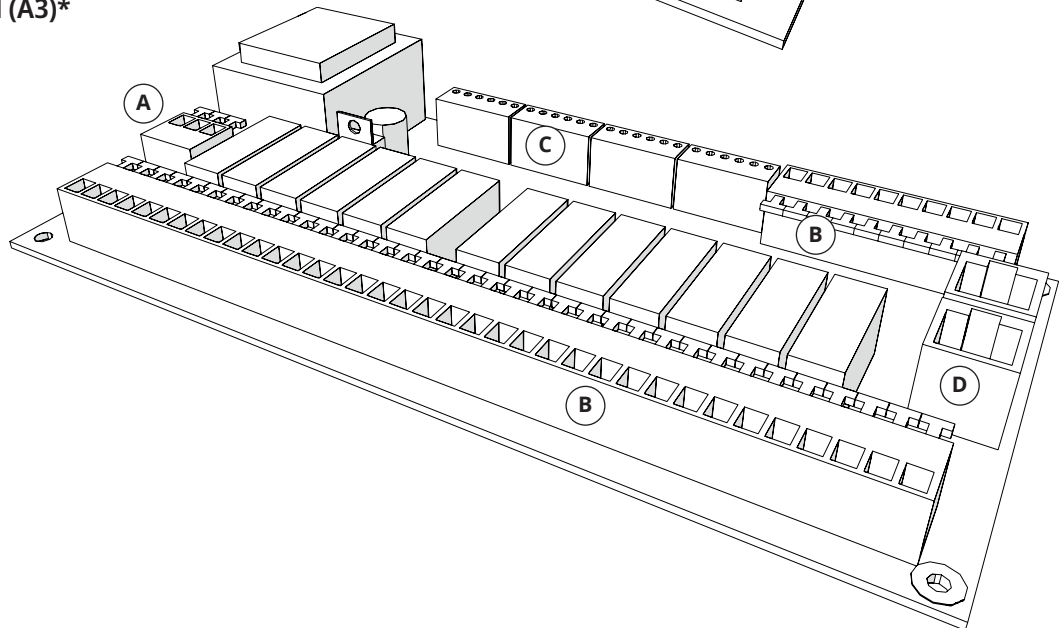

* Supplied with CTC EcoLogic XL/L.
Accessory pack available for CTC EcoLogic M.

I/O board (A7)**

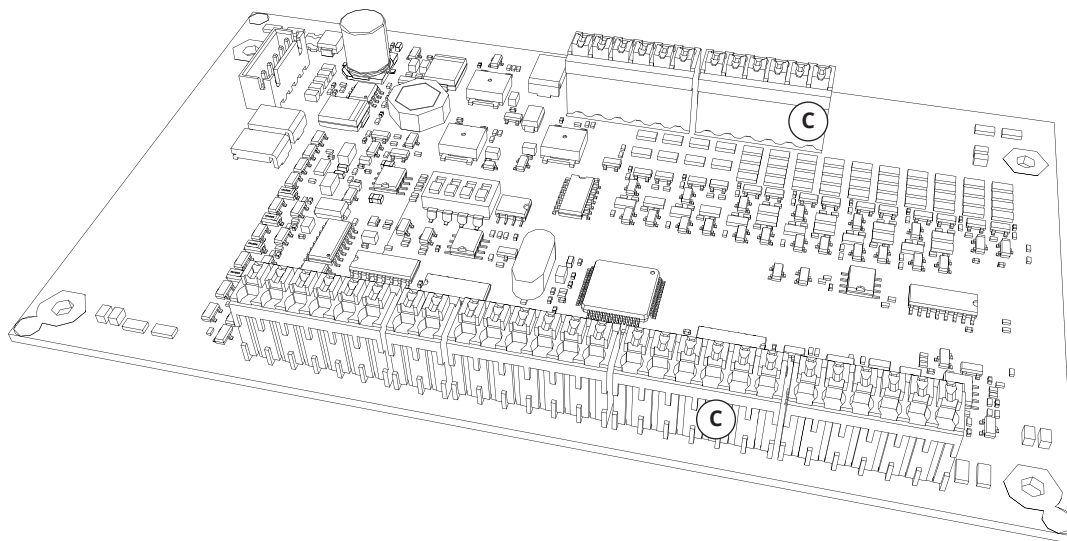

4.1.2 Display unit

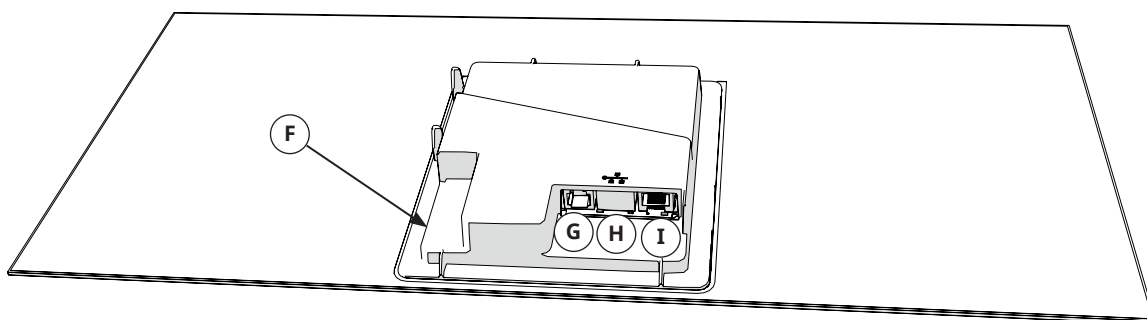

- | | | | |
|---|--|---|---|
| A | Power supply 230V | F | USB port |
| B | Terminal block 230V | G | BMS connection |
| C | Terminal block, low voltage | H | Network connection (Ethernet) |
| D | Communication display unit relay/expansion board | I | Display unit power supply/ internal communication |
| E | Communication, heat pump | | |

**** Supplied with CTC EcoLogic XL.
Accessory pack available for CTC EcoLogic L/M.**

4.3 Scope of delivery

The figure below shows the main components in the CTC EcoLogic delivery.

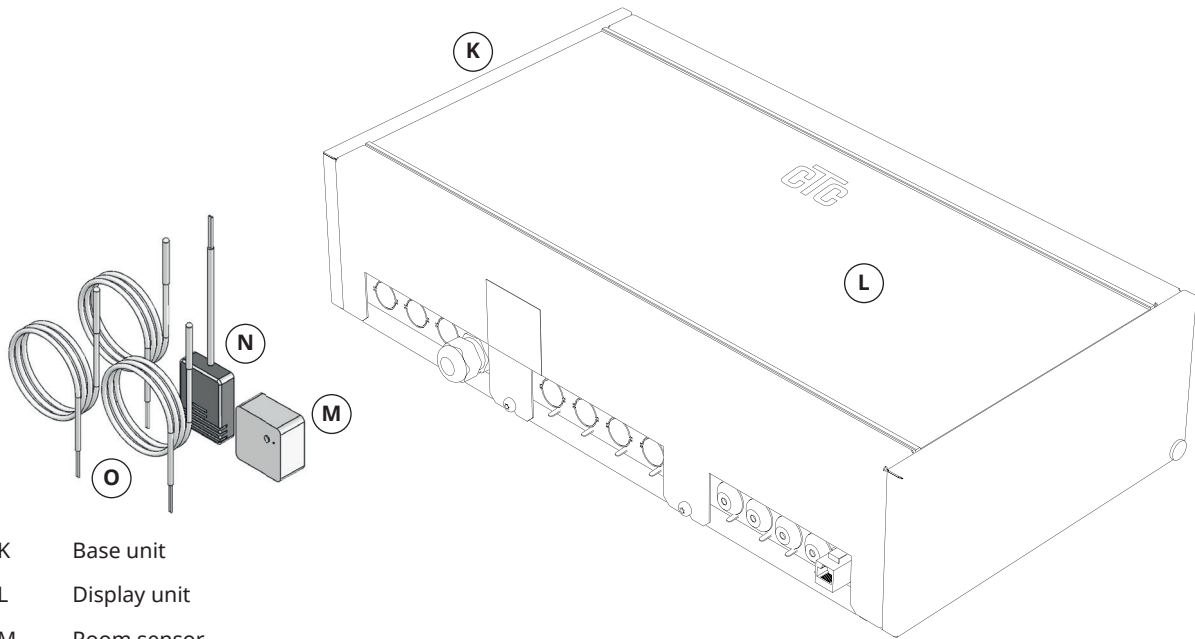

- K Base unit
- L Display unit
- M Room sensor
- N Outdoor sensor
- O 3 x Primary flow sensors (22k)

4.2 Heating circuit

CTC EcoLogic can control up to four* heating circuits using room sensors – for example, two radiator circuits and two floor heating circuits.

The required curve inclination and adjustment is set when operating outdoor sensors only. This value is different from home to home and should be adjusted to suit your needs.

A room sensor that is correctly positioned provides more comfort and more heating circuit savings. The room sensor picks up the current indoor temperature and adjusts the heat, for example when it is windy outside and the house is losing heat, which the outdoor sensor is unable to register. During solar insolation, or other instances when heat builds inside the house, the room sensor can also reduce the heat supplied, thus saving energy. Another way to save energy is to use the night reduction function, which reduces the indoor house temperature at certain times or periods, for example during the night or when you are away on holiday.

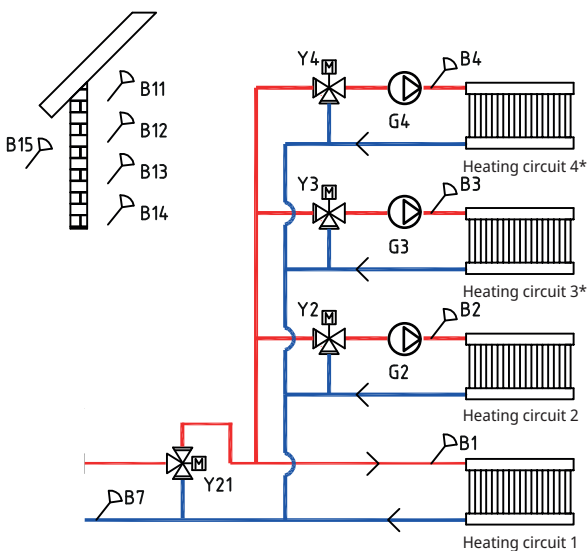

Degree minutes, System Types 1-3

For System Types 1, 2 and 3 (see the schematic diagrams for System Types 1 to 6 in the "Pipe installation" chapter), the control system measures the temperature in the heating circuit each minute. Once a certain cumulative heat loss (measured in degree minutes) is measured, the heat pump is started up to compensate for the loss.

"Degree minutes" refers to the product of the cumulative heat loss in degrees (°C) and the time measured for this in minutes. For example, 60 degree minutes may arise if a total of one degree of heat loss accumulates for one hour, or three degrees of cumulative heat loss is measured after 20 minutes.

*Applies CTC EcoLogic XL/L.
CTC EcoLogic M can control up to two heating circuits

The first heat pump starts when heat loss reaches 60 degree minutes (factory setting) and stops when the system has recovered the loss (at 0 degree minutes). If several heat pumps are connected at the same time as the heat loss increases, heat pump 2 starts when there is a loss of 90 degree minutes (the factory-set difference between the heat pumps is 30 degree minutes). If additional heat is needed, this is added when there is a heat loss of 500 degree minutes and stops at 400 degree minutes (both values are factory set).

Buffer Tank, System Types 4-6

If a buffer tank is connected (see the schematic diagrams for Systems Types 4 to 6 in the "Pipe Installation" chapter), the heating circuit can be kept at a constant temperature.

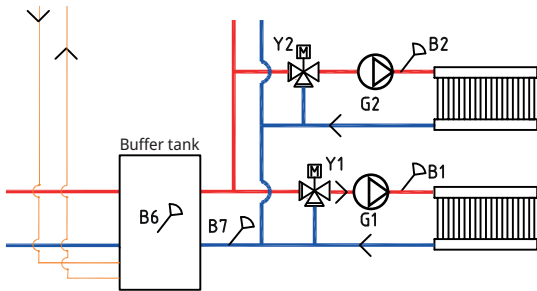

The heat pump is controlled based on the temperature in the buffer tank. The compressor starts at a certain predefined time after the sensor in the tank measures a temperature that is lower than the setpoint for the tank and stops when the tank measures a temperature difference that is set higher than the setpoint for the tank. The indoor temperature in conjunction with the outdoor temperature and chosen heat curve determine at which temperature the primary flow temperature will be aimed.

4.3.1 Heat pump

CTC EcoLogic can control up to ten heat pumps*, two of which can be connected via 3-way valves to deliver heat to either the heating circuit or the DHW circuit.

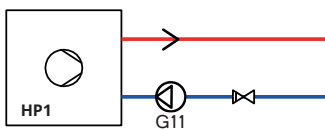

Heat pump operation is a so-called floating condensation, where the heat pump heats to the temperature required by the heating circuit. This temperature varies depending on the outdoor temperature and which set inclination and adjustment of the heat curve has been chosen. Installed room sensors affect the temperature required in the heating circuit.

Savings from a heat pump are directly linked to the COP value. COP means the output in proportion to the supplied power. Thus, COP = 3 means that for 1 kW of supplied power from the compressor, 3 kW of heat output is produced.

The lower the temperature the heat pump needs to produce, the higher the COP value obtained from the heat pump, as this is a more advantageous operation for the compressor. The heat pump therefore only heats to the temperature required by the heating circuit. This is economical in terms of the service life of the compressor and in maximising operating economy.

4.3.1.1 More than two heat pumps*

Two heat pumps can be connected via 3-way valves that alternate the charging between the DHW tank and the heating circuit. If more than two heat pumps are installed, these are connected to the heating circuit. The heat pumps are connected via the Modbus communication interface.

When two or more heat pumps are connected to the same system, the common pipes, 3-way valves and mixing valves must be sized so that they are able to cope with the total flow from the heat pumps. Check the flow of the heat pumps by comparing primary/return/outdoor temperature (refer to the "Installation and Maintenance Manual" chapter in the heat pump manual).

4.3.1.2 Prioritisation of heat pump operation

When CTC EcoLogic controls two or more heat pumps of different sizes, the connected heat pumps are divided into two categories: small or large heat pumps. Dividing the available heat pumps into two different size categories means it is possible to change the output in small steps and in this way achieve modulating operation.

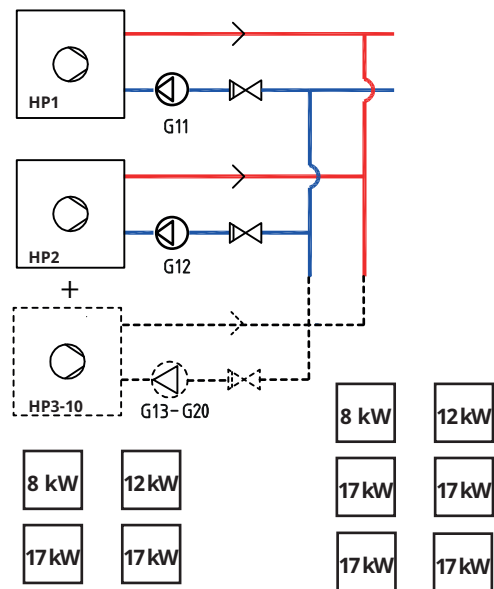

In the example above, 8 kW and 12 kW are classed as small, while the two 17 kW machines are classed as large.

In the example above, 8 kW and 12 kW are classed as small, while the four 17 kW machines are classed as large.

When, for example, a need for power occurs, a large heat pump is switched on at the same time as a small heat pump is switched off, and vice versa when

*Applies CTC EcoLogic XL/L.
CTC EcoLogic M can control up to two heating pumps

reducing power. Within both the small and large groups, reciprocal heat pump operation is prioritised according to accumulated operation time.

When combining different types of heat pumps, air/water and ground source pumps are prioritised according to the current outdoor temperature.

4.3.1.3 Different Heat Pumps

CTC EcoLogic can control different types of CTC heat pumps, for example, CTC EcoAir (air/water heat pump) and CTC EcoPart (liquid-to-water heat pump).

The outdoor temperature at which CTC EcoAir is prioritised over CTC EcoPart is set in the "Advanced/Settings/Heat Pump" menu. This means that the operating economy can be maximised, as at a high outdoor temperature a greater energy yield is obtained from the CTC EcoAir than from the CTC EcoPart. This combination works exceptionally well for installations where, for example, the ground source heat pump is undersized. An air-to-water heat pump can then be used to give the bedrock a longer time to 'recover' and provide the system with increased power.

4.3.1.4 Pressure/level switch

In some cases, extra protection is required due to local requirements or provisions. For example, the requirement in some areas is for the system to be installed within a water catchment area.

The pressure/level switch connects to terminal blocks K22/K23/K24/K25 and is then defined in the "Advanced/Define/Def. Heat Pump" menu. If there is a leak, the compressor and brine pump stops and the Flow/level switch alarm appears on the display.

4.3.1.5 Speed-controlled charge pump

Each heat pump should have a separate charge pump that starts and stops together with its respective heat pump. If the charge pump is speed-controlled, the flow will be automatically set without adjustment via the control valve.

In the heating circuit, the charge pump will work towards a fixed difference between supply and return from the heat pump.

If a speed-controlled charge pump is not installed, the flow may be adjusted manually in accordance with the heat pump's manual. The difference between incoming and outgoing water from the heat pump will vary depending on the operating conditions during the year.

When the outdoor temperature is less than +2 °C, the charge pumps must start in order to protect against frost in cases where an air/water heat pump is installed. A speed-controlled charge pump will only work at 50% of its maximum capacity. This provides for increased savings on the charge pump's operating economy. In addition, the heat losses are lowered compared with a charge pump with a fixed speed setting.

4.4 DHW

DHW can be directed from heat pumps, solar collectors and additional heat to the DHW tank.

The required DHW comfort level is set in the DHW menu. In this main menu, it is possible to schedule increased water temperatures during certain times of the day.

The stop temperature in the DHW tank is factory-set at 55°C. When DHW is being drained and the temperature in the tank falls to 5°C below the stop temperature, the heat pump starts and raises the water temperature towards the set stop temperature.

The stop temperature is adapted to DHW needs and to the heat pump model installed.

When there is a requirement for heat in the house at the same time, the heat pump charges the heating circuit even when the stop temperature (55°C) in the DHW tank has been reached.

4.5 Additional heat

CTC EcoLogic can control an external additional heat source (pellet, oil, gas or electric boiler) which is connected before or after the DHW system.

In the "Advanced/Settings/Additional Heat" menu, systems 1, 2 and 3 can be set according to the cumulative heat loss in degree minutes at which CTC EcoLogic will start the additional heat as well as the difference between the start and stop of the additional heat. Additional heat is factory set to start when there is a loss of 500 degree minutes and to stop when the loss totals 400 degree minutes (set difference = 100 degree minutes).

For System Types 4, 5 and 6, additional heat can be set to start at a certain time after heat loss occurs in the tank. The factory setting is 180 minutes.

4.5.1 Wood boiler

In system 1, CTC EcoLogic can be connected to a wood boiler.

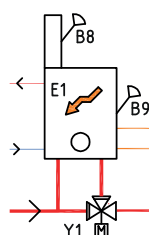

When wood-firing is started and the flue gas sensor reaches the value set in the "Advanced/Settings/Additional Heat/Start Flue Gas °C" menu (factory-set to 'Off'), the control activates the "Wood operation" status.

When wood operation is active, the heat pump(s) or additional heat are not used

for heating. When the flue gas sensor is below the set value, wood operation status is interrupted.

A charging system such as Laddomat 21 is recommended for the wood boiler for optimum performance. In special cases, for instance operating a water-jacketed stove, a charge pump controlled directly by the flue gas temperature can be used.

Wood operation can also be activated when the primary flow sensor (B1) is 10 °C above the setpoint.

4.6 Pool*

For System Types 4 to 6, the pool can be connected in parallel with the heating circuit via a heat exchanger in order to separate the liquids.

Via a sensor in the pool, the pool's charge pump starts and stops in order to maintain the set temperature in the pool (factory set at 22°C) and the temperature is allowed to fall by 1°C before the charge pump starts again. It is also possible to set a high and low pool priority, which determines whether additional heat will be used to heat the pool. See the "Advanced/Settings/Pool" menu.

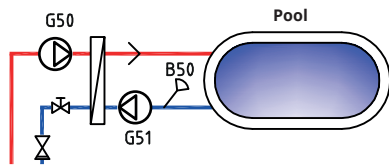

4.7 Solar collectors*

Solar collectors can be connected to the buffer tank, DHW system and the bedrock/ground source heating circuit via 3-way valves.

When the temperature rises and the temperature difference exceeds 7°C (factory setting) between the solar collectors and the DHW tank, the charge pump starts and transfers the solar heat to the DHW system. The speed-controlled pump controls the flow so that it always delivers a temperature of at least 7°C higher. This means that if solar collector output rises, the charge pump will increase the flow, and if solar collector output decreases, the charge pump will reduce the flow. When the DHW tank temperature increases or the solar collectors drop in temperature and the temperature difference becomes 3°C (factory setting), the charging stops and does not start again until the temperature is at least 7°C warmer than in the DHW tank.

If both the DHW tank and buffer tank are defined, the DHW tank is prioritised. Charging first takes place to the DHW tank; once the set setpoint has been reached, charging changes to the buffer tank. Charging continues until a need for DHW arises or the set setpoint has been reached.

There are protective functions for the solar collectors/ the collector (refer to the "Advanced/Settings/Solar collectors/Protection Collector" menu).

Heat exchangers and pumps (G32) do not need to be installed to the solar heating circuit if there is already an existing loop in the connected DHW/heating tank.

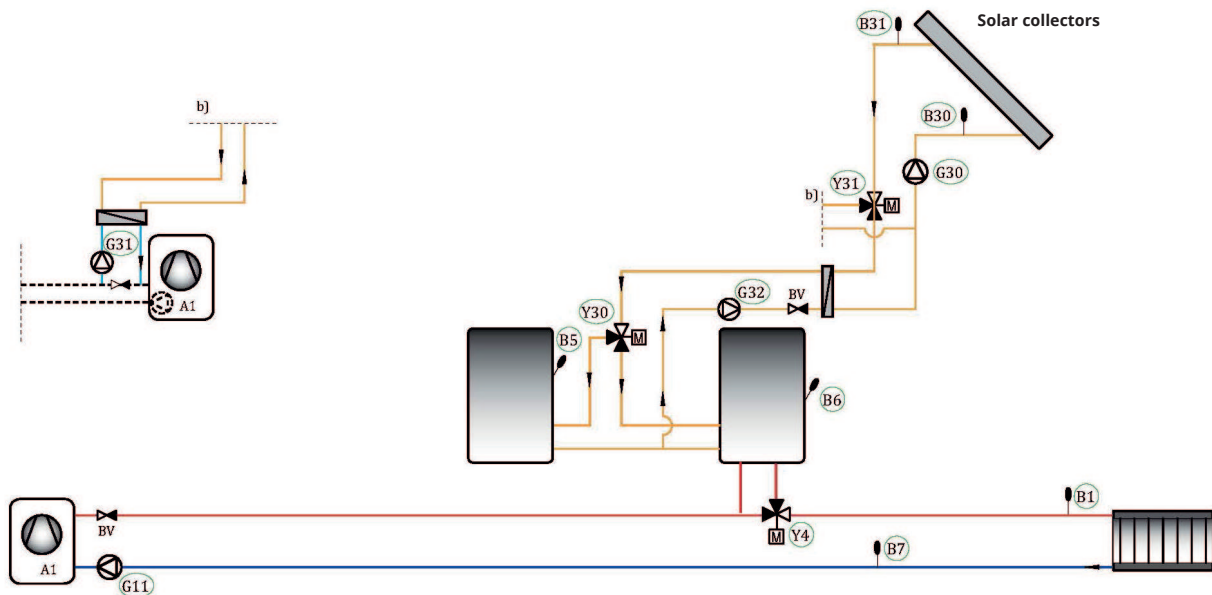

*Applies CTC EcoLogic XL/L.

4.8 Recharging borehole/ground*

If a liquid/water heat pump (the CTC EcoPart) is used, a diverting can be installed in the solar circuit and connected to the brine circuit (borehole/ground loop) to recharge the brine circuit when the DHW tank/buffer tank are fully charged (factory set at 85°C), or when the temperature in the solar collectors is not sufficiently high to charge the tank but is able to provide an addition to the brine circuit. Refer to the "Settings/Solar collectors/Max DHW Tank °C" menu or the "Settings/Solar collectors/Max Buffer tank °C" menu.

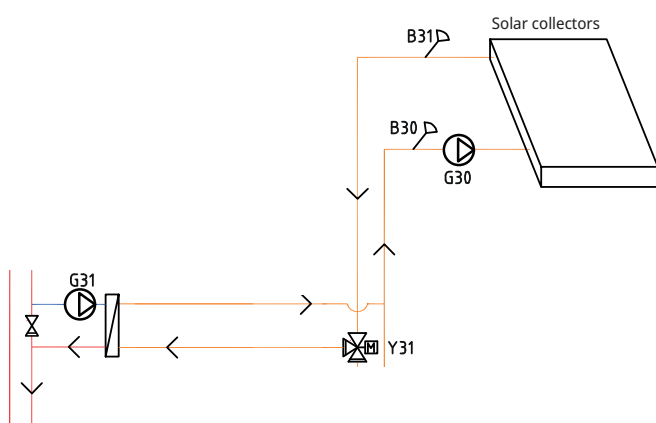

The solar collector temperature should be factory set at 60 °C warmer than the brine temperature for the charging to start (refer to the "Advanced/Settings/Solar collectors/dT Max Bedrock °C" menu). When the difference between the temperature in the solar collectors and the brine circuit falls to 30°C, the charging is stopped. If the brine circuit temperature becomes warmer than the set value, recharging will also be interrupted, as the temperature then becomes too high for the heat pump to work (refer to the "Advanced/Settings/Solar collectors/Max Brine °C" menu).

When the solar energy system works towards the brine circuit, the flow is factory set to switch to the DHW circuit every thirty minutes (refer to the "Advanced/Settings/Solar collectors/Test Frequency Min" menu) to check whether charging is possible, since the DHW circuit always has the highest priority. If possible, charging towards the DHW tank will continue. Otherwise the charging reverts to the brine circuit.

4.9 Free cooling*

Free cooling – also called “natural cooling” or “passive cooling” – exploits the free cooling found in bedrock. A bedrock/ground source heat installation is easily supplemented with a fan convactor, a circulation pump, pipe and pipe parts, e.g. CTC EcoComfort. Operating costs are very low as the cold itself does not need to be produced, instead being simply transferred from the bedrock to the house.

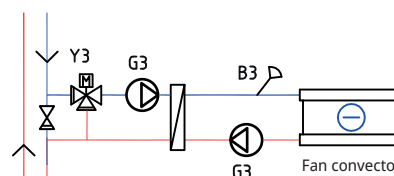

In the "Advanced/Settings/Cooling" menu, the temperature from which cooling will be permitted, among other things, can be set.

4.10 Active cooling*

Active cooling is when the heat pump is used to produce cooling. CTC Ecologic system 4 and 5 are systems for heating or cooling with a buffer tank. The DHW tank, cooling tank and buffer tank can have one or two temperature sensors.

An active heat pump always produces both heat and cool. Active cooling is when the cool from the heat pump is used to cool the building.

4.10.1 Active cooling air-to-water heat pump

When active cooling is used with an air-to-water heat pump the heat is dumped outside.

4.10.2 Active brine cooling, ground/heat pump**

Brine cooling is when the low temperature of the brine is used, but also actively is cooled down by the heat pump. The heat that is extracted when the brine flow is cooled is stored, if possible, in a DHW tank, buffer tank or a pool. When the system can't store more heat, the heat is instead dumped into the boreholes or into the outdoor air.

When the brine has been cooled by the heat pump, the brine goes to a heat exchanger where the water in the distribution system is cooled down before the flow is led back to the boreholes. If there is a high demand for cooling, the brine goes directly back to the heat pump instead of going to the bore holes.

*Applies CTC EcoLogic XL/L.

4.10.3 CTC EcoLogic System 4

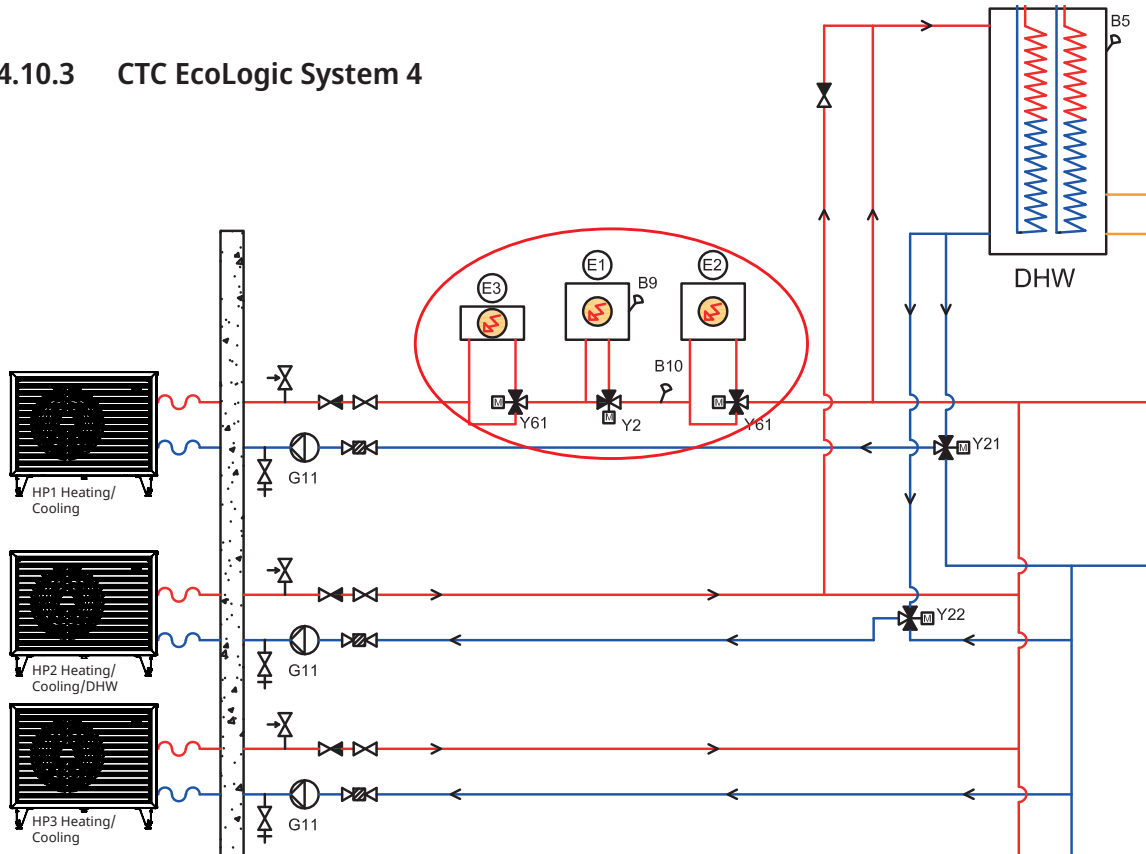

CTC EcoLogic System 4 - bypassing additional heat during cooling. Example with three heat pumps.

- Diverting valve (Y61) is activated when heat pump(s) produce cooling. Additional heat (E1-E3) is bypassed if the 3-way valve is installed.
- The mixing valve (Y2) is closed for additional heat during cooling.
- Diverting valve heat dumping (Y64)* is used when excess heat is to be directed to heat dumping.
- Proportional diverting valve cooling (Y70)** is used to divide available cooling to the cooling tank and/or collector.
- Return sensor (B73) is used to read the temperature of the cooling flow from the heating system.
- Sensor, proportional diverting valve (B70)** is used to read the temperature of the outgoing brine.
- Sensor, heat exchanger cooling tank (B75)** is used to read the temperature between the exchanger and cooling tank.
- All heat pumps of model CTC EcoAir 700M (1-10 HP)/CTC EcoAir C100 (1-4 HP) can produce cooling**. They are connected to diverting valve (Y61).
- All CTC EcoPart heat pumps can produce active brine cooling in combination with the CTC EcoLogic XL control unit.

- Max. two heat pumps (HP1 and HP2) are used to produce hot water (via 3-way valve (Y21) and (Y22)).

Common tank, heating/cooling

- When switching from heating to cooling:
 - Heating is deactivated.
 - Delay until cooling is allowed (see menu "Advanced/Settings/Cooling").
- When switching from cooling to heating:
 - Heating is activated.
- Cooling and heating cannot be active at the same time.

Separated tank, heating/cooling or No cooling tank

- Cooling and additional heat sources cannot be active at the same time. (Applies to air-to-water heat pump).
- Cooling and heating can be active at the same time.

4.10.4 CTC EcoLogic System 5

Common and separated heating/cooling

- The only difference compared to system 4 is that system 5 lacks additional heat (E2-E3).

*Applies to CTC EcoLogic XL/L.

**Only applies to CTC EcoLogic XL.

4.10.5 Electrical components

The following electrical components must be installed during active cooling:

- Sensor (B61 and B77) in cooling tank.
- Return sensor (B73).
- Primary flow sensor 3 (B3)
When separated heating/cooling, the system is controlled with (B3).

- Diverting valve, heating/cooling (Y61).
With separate heating/cooling tank and to bypass additional heat.
- 3-way valve, cooling relay (Y62).
To avoid heat loss from the heat tank in a separate heating/cooling tank system. The external control signal that is sent when cooling demand is active can also be used for, for example, a floor heating system.

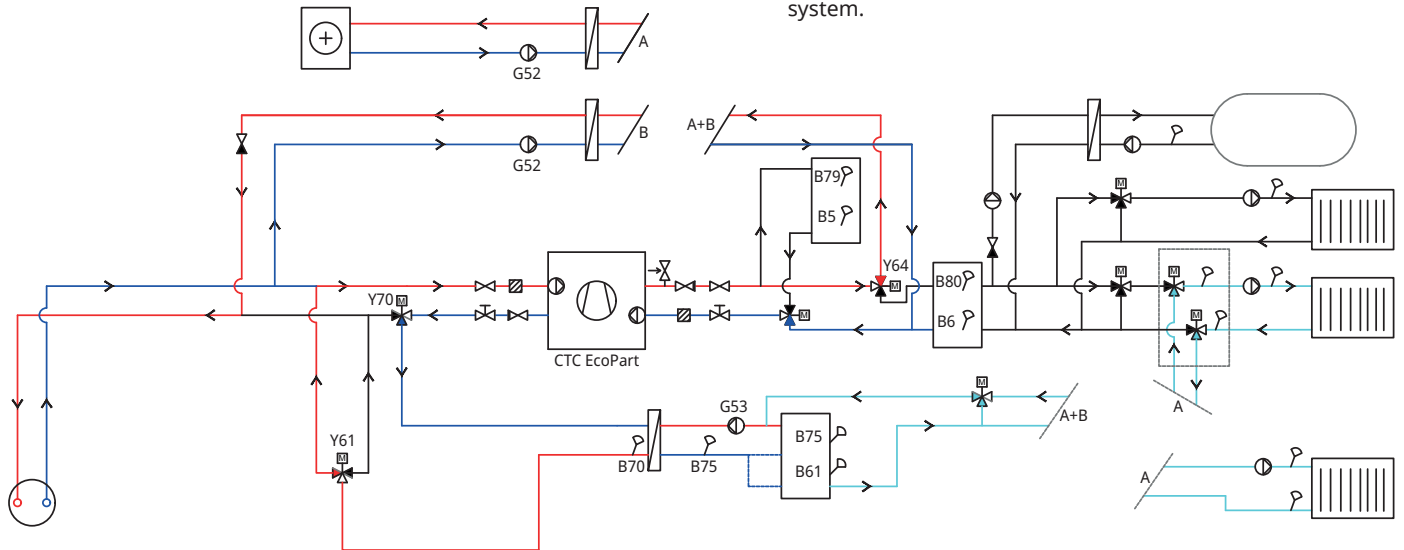

CTC EcoLogic System 4/5 - active brine cooling.
Sensors B77, B79 and B80 only applies to CTC EcoLogic XL.

4.10.6 Distribution Heating/Cooling

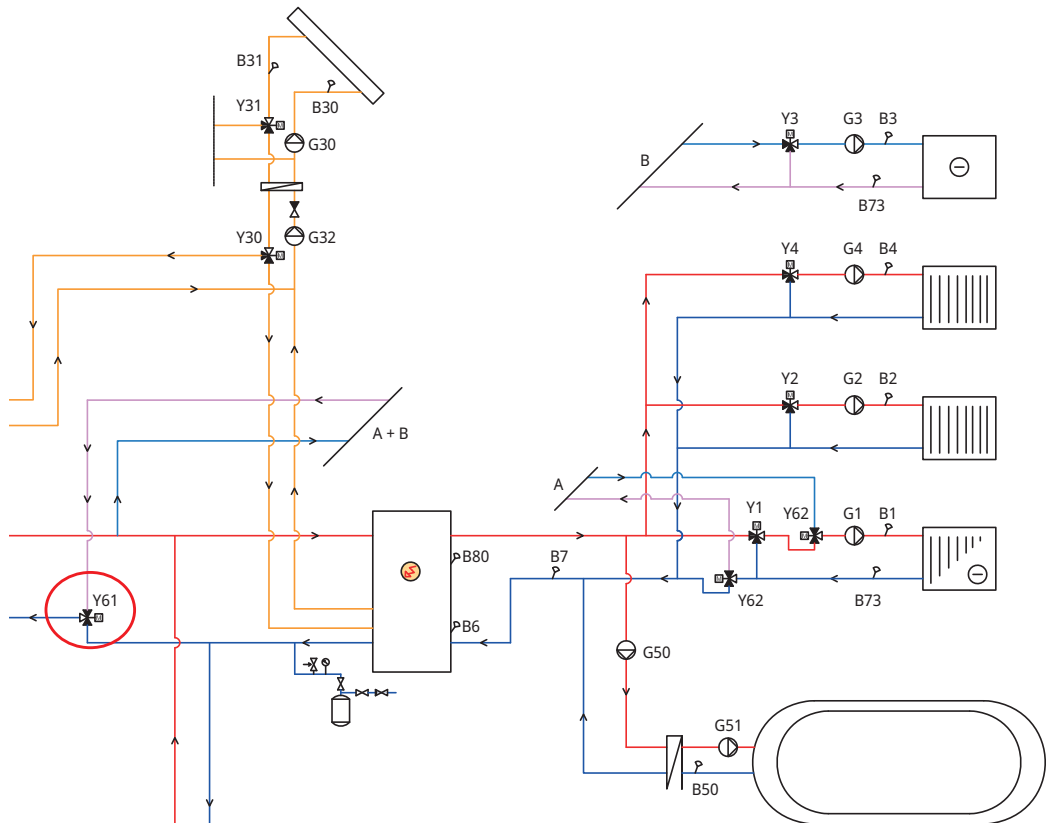

CTC EcoLogic System 4/5 - Cooling tank is missing in the system.

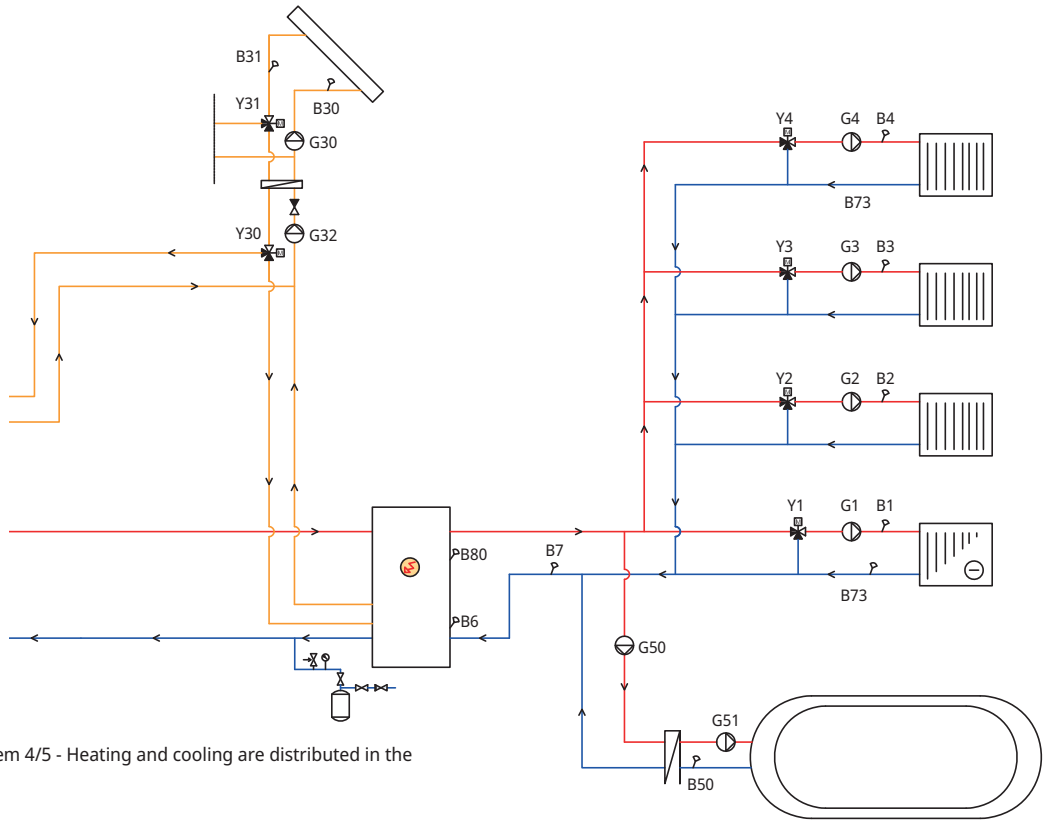

CTC EcoLogic System 4/5 - Heating and cooling are distributed in the same buffer tank.

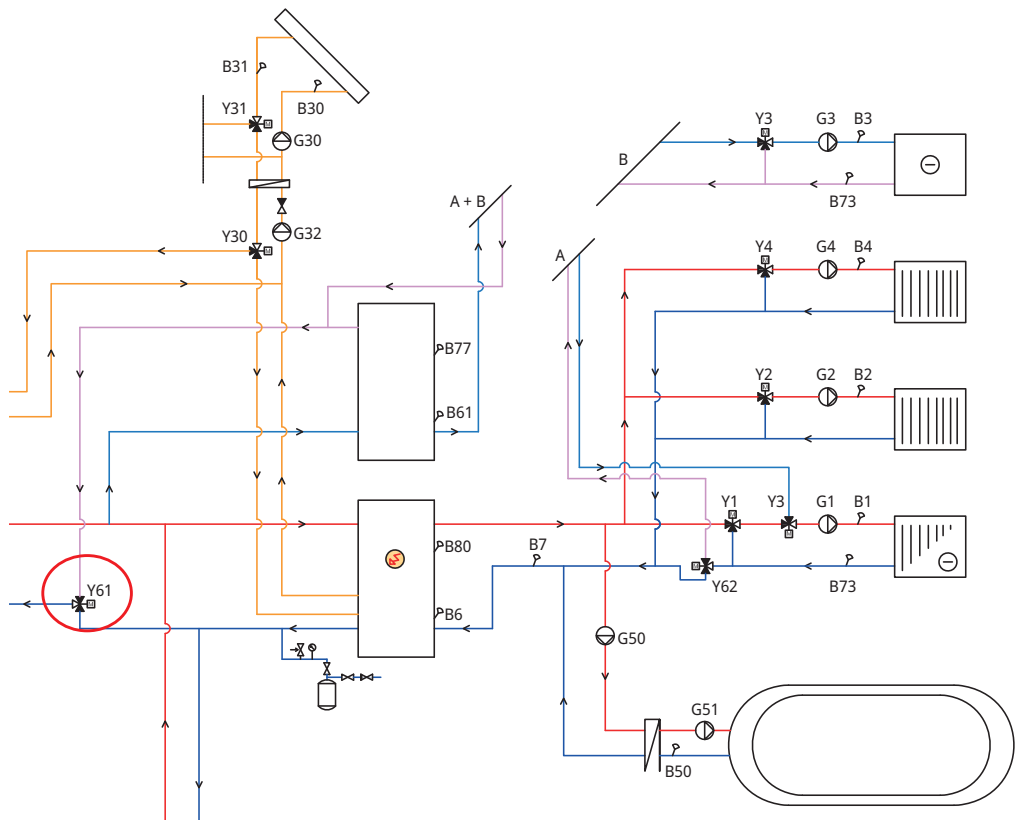

CTC EcoLogic System 4/5 - Cooling is distributed in a separate cooling tank.

4.10.7 Control logic, consumer

The control logic for the consumer is described below. See the "Settings Cooling" section of the "Control system" chapter for more information about relevant menu settings.

Active cooling must be defined in the "Advanced/Define/Cooling" menu in order to be activated as shown below.

Common heating/cooling

Active cooling in a common system is permitted if the following criteria are met at the same time:

- the delay time has passed after the production of heat has ended.
--> see menu bar "Heating off, delay".
- the outdoor temperature exceeds (or is equal to) the temperature from which cooling is to be permitted.
--> see the "Cooling permit. from outdoor T °C" menu.

Non-common heating/cooling

Active cooling in a separate system is permitted if the following criteria are met at the same time:

- the outdoor temperature exceeds (or is equal to) the temperature from which cooling is to be permitted.
--> see the "Cooling permit. from outdoor T °C" menu.
- For systems with common tank, heating/cooling: the delay time has passed after the production of heat has ended.
--> see menu bar "Heating off, delay".

Room sensor installed

If a room sensor has been installed, active cooling is permitted if the following criteria are met at the same time:

- the room temperature exceeds (or equals) the set value plus the set temperature diff.
--> see the "Room temp cooling °C" menu.
--> The temperature diff. is set in the "Service/Coded settings" menu.
- when the delay time has passed.
--> see the "Start delay" menu.

Active cooling is stopped when the room temperature is less than (or equal to) the set stop temperature minus the set temperature diff.

Room sensor not installed

- Cooling is activated when the delay time has passed.
--> see the "Start delay" menu.

Block cooling

- Cooling can be temporarily deactivated by blocking cooling externally without any effect on delays.
--> see the "Ext. block cooling" menu.

Primary flow temperature

- The minimum primary flow temperature is calculated from the value set for the primary flow temperature at outdoor temperatures of +20 °C and +40 °C respectively.
--> see the "Primary flow at outdoor temp +20 °C/+40 °C" menus.
- The estimated diff. is calculated from the diff. set value permitted between the primary flow and return temperature of the cooling flow at outdoor temperatures of +20 °C and +40 °C respectively.
--> see the "Primary flow diff. outdoor temp +20 °C/+40 °C" menus.

Every x minutes, a new primary flow temperature is calculated based on the return temperature.
--> see the "Diff delay calc." menu.

If the value is lower than the minimum primary flow temperature, then this sets the minimum primary flow temperature.

Mixing valve control is calculated from the current and estimated primary flow temperature.

4.10.8 Alarm logic cooling

An alarm is triggered if:

- The cooling flow temperature is lower than the set value (factory setting: 18 °C) minus 0.5 °C.
The value is set on the menu bar "Min. flow temp cooling" in the menu "Advanced/Service/Coded settings/Cooling".

or

- For a common system: the primary flow temperature is lower than the room temperature minus the set flow diff. (factory setting: 5 °C) minus 0.5 °C.
The "flow diff." value is set on the menu bar "Max. diff. room temp. cooling °C" in the "Advanced/Service/Coded settings/Cooling" menu.

If any of the conditions are met for 10 minutes, the mixing valve (Y3) closes for 5 minutes at separated heating/cooling. The mixing valve is permitted to control the system for a total of 30 minutes. If the error persists after this time, the alarm will be triggered and appear in the display on the start menu.

5. House heating settings

The House Heating Curve

The heating curve is the central part of the product's control system. It is the heating curve which determines the compensated flow temperature requirements for your property dependent upon the outdoor temperatures. It is important that the heating curve is correctly adjusted, so that you achieve the best operation and economy possible.

One property requires a radiator temperature of 30 °C when the outdoor temperature is 0 °C, whilst a different property requires 40 °C. The difference between different properties is determined by the radiator surface area, the number of radiators and how well insulated the house is.

Adjusting the heating curve

In the "Heating curve" menu under "Settings/Heating circuit", you can fine adjust the values of the heating curve for the primary flow temperature in relation to the outdoor temperature in the graph, as well as set the values for curve inclination and curve adjustment for the heating circuit.

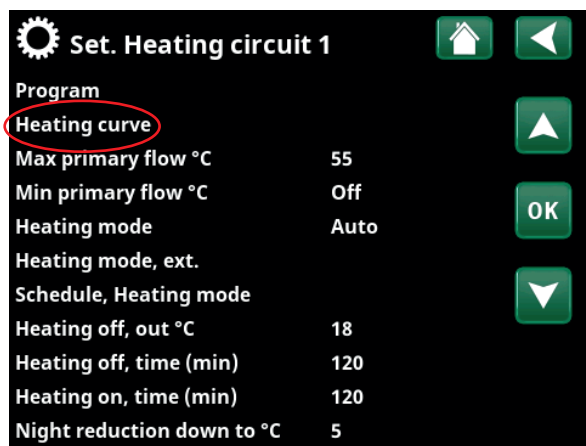

Part of the "Advanced/Settings/Heating Circuit/Heating Circuit 1" menu.

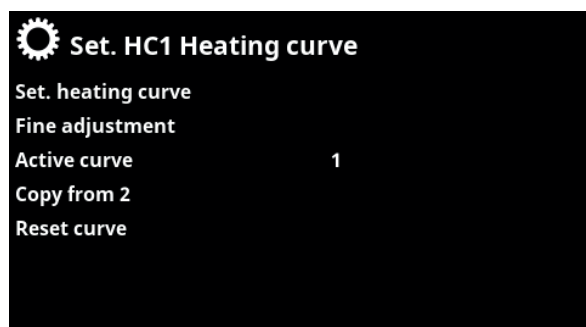

Menu: "Advanced/Settings/Heating Circuit/Heating Circuit 1/Heating curve". Active curve: #1.

Ask your installer to help you set these values.

It is extremely important to set the heating curve and, in some cases, unfortunately, this process may take several weeks. The best way of doing this, upon the initial start-up, is to select operation without any room sensor. The system then operates using the outdoor temperature reading and the property's heating curve only.

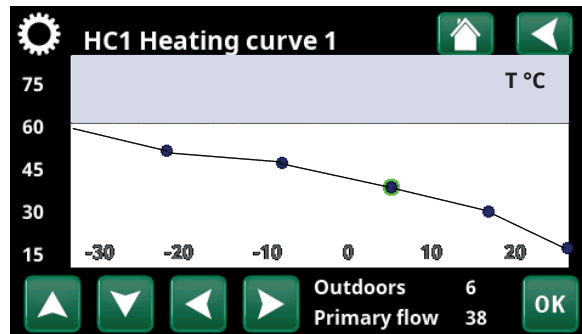

Menu: "Advanced/Settings/Heating Circuit/Heating Circuit 1/Heating curve/Fine adjustment".

For more information on how to set the heating curve, see section "Heating curve" in chapter "Settings / Heating circuit".

During the adjustment period it is important that:

- the night reduction function is not selected.
- all thermostat valves on the radiators be fully opened. (This is to find the lowest curve for the most economical use of the heat pump).
- the outdoor temperature is not higher than +5 °C.
- the radiator system is operational and correctly adjusted between different circuits.

Appropriate Default Values

During installation you can seldom achieve a precise setting for the heating curve instantly. In this case, the values given below may provide a good starting point. Radiators with small heat-emission surfaces require a higher primary flow temperature.

Floor heating only:	Inclination 35
Low temperature system: (well insulated houses)	Inclination 40
Normal temperature system: (factory setting)	Inclination 50
High temperature system: (older houses, small radiators, poorly insulated)	Inclination 60

Adjusting the heating curve

The method described below can be used to adjust the heating curve correctly.

Adjustment if it is too cold indoors:

- If the outdoor temperature is **lower** than 0 °C: Increase the Inclination value by a couple of degrees. Wait 24 hours to see if any further adjustment is required.
- If the outdoor temperature is **higher** than 0 °C: Increase the Adjustment value by a couple of degrees. Wait 24 hours to see if any further adjustment is required.

Adjustment if it is too warm indoors:

- If the outdoor temperature is **lower** than 0 °C: Decrease the Inclination value by a couple of degrees. Wait 24 hours to see if any further adjustment is required.
- If the outdoor temperature is **higher** than 0 °C: Decrease the Adjustment value by a couple of degrees. Wait 24 hours to see if any further adjustment is required.

i The set heating curve always takes priority. The room sensor can only increase or decrease the heat beyond the set heating curve to a certain extent. Where operating without a room sensor, the selected heating curve determines the flow temperature supplied to the radiators.

Examples of Heating Curves

You can see in the diagram below how the heating curve changes with different Inclination settings. The gradient of the curve shows the temperatures that the radiators require at different outdoor temperatures.

Curve inclination

The inclination value which is set is the primary flow temperature when the outside temperature is -15 °C.

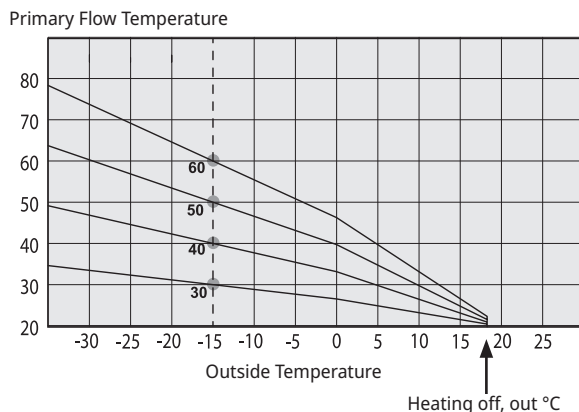

Curve adjustment

The curve can be parallel displaced (adjusted) by the desired number of degrees to adapt to different systems/houses.

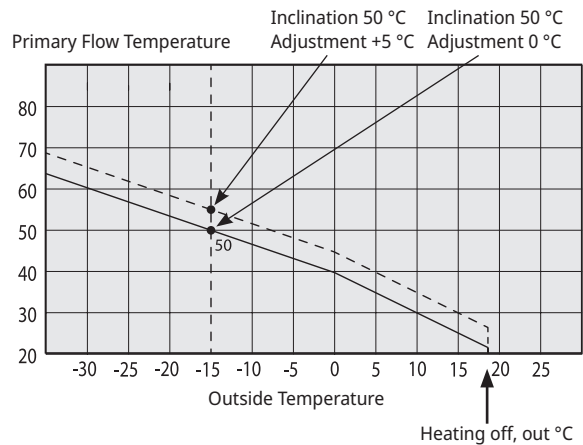

Example

Curve inclination 60 °C
Curve adjustment 0 °C

In this example, the maximum outgoing primary flow temperature is set at 55 °C. The minimum permitted primary flow temperature is 27 °C (e.g. summer-time basement heating or the floor circuits in a bathroom).

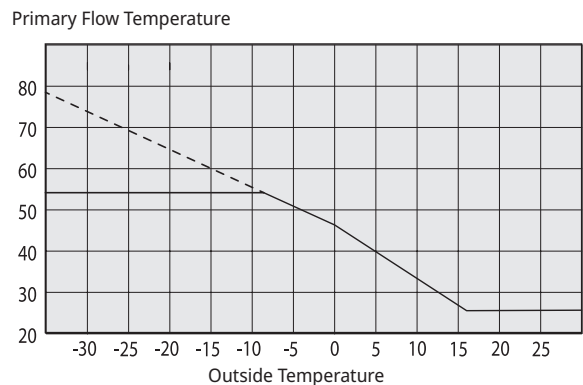

i If the values set are too low, this may mean that the desired room temperature is not being reached. You then need to adjust the heating curve, as necessary, following the method shown above.

Summer season

All properties have internal heat gains (lamps, oven, body heat, etc.), which means that the heating can be switched off when the outdoor temperature is lower than the desired room temperature. The better insulated the house is, the earlier the heating from the heat pump can be switched off.

The example shows the product set at the default value of 18°C.

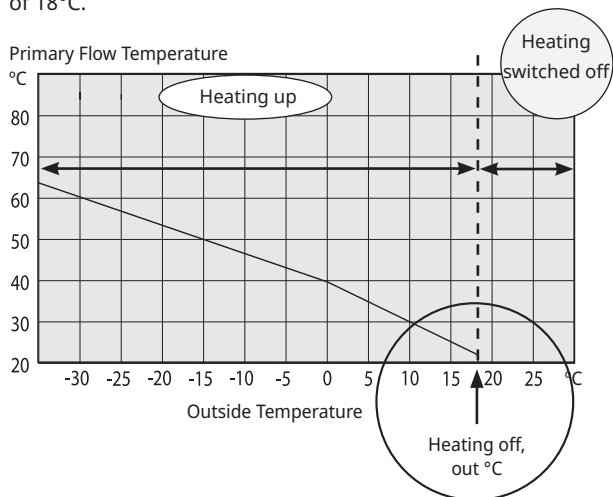

This value, "Heating off, out °C", can be changed in the "Advanced/Settings/Heat circuit" menu.

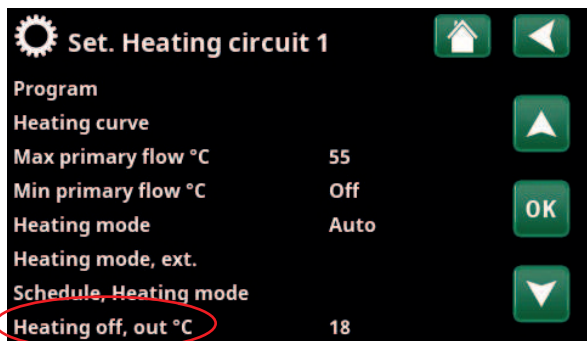

Part of the "Advanced/Settings/Heating Circuit/Heating Circuit 1" menu.

In systems with a radiator pump, the radiator pump stops when the heat is switched off. The heating starts up automatically when it is required again.

See chapter "Settings/Heating circuit" for information on setting the heating mode.

6. Technical data

Supply	230V 1N~
Max fuse size	10A
Total max load CTC EcoLogic	10A
Max load relay output	4A
Electrical data 3-way valve	230V 1N~
Electrical mixing valve motor	230V 1N~
Output additional heat (external additional heat source E1, E4)	230V 1N~ , max 4A
Sensor (protective extra low voltage), NTC 22k, °C/ohm	0/66k, 10/41.8k, 15/33.5k, 20/27.1k, 25/22k, 30/18k, 35/14.8k, 40/12.2k, 50/8.4k, 60/6.0k, 70/4.3k, 80/3.1k, 90/2.3k, 100/1.7k
Discharge sensor, type NTC 3.3, °C/ohm	20/61.5k, 30/39.5k, 40/26k, 50/17.5k, 60/12.1k, 70/8.5k, 80/6.1k, 90/4.5k, 100/3.3k, 110/2.5k, 120/1.9k, 130/1.5k, 150/0.9k
Outdoor sensor, type NTC 150, °C/ohm	-20/1.11k, -10/681, 0/428, 10/276, 20/182, 30/123, 40/85
Solar collector sensor*, type PT1000, °C/ohm	-10/960, 0/1000, 10/1039, 20/1077, 30/1116, 40/1155, 50/1194, 60/1232, 70/1271, 80/1309, 90/1347, 100/1385, 120/1461, 140/1535
Display	4.3 inches, colour, touch
Memory	maintains the memory in the event of a power failure
Back-up batteries	not needed
Clock	real-time
Dimensions, connection box (w x h x d)	504 x 276 x 122mm

*Applies to CTC EcoLogic XL/L.

7. Display settings

All settings are made directly on the display of the easy-to-use control unit. The large icons function as buttons on the touch screen.

Operational and temperature information is also shown here. You can easily access the different menus to find information on the operation or to set individual values.

Submenus that do not fit on the display can be accessed by pressing the down arrow on the display or by scrolling down manually. A white scroll bar shows where you are.

7.1 Start page

This menu is the system's start page. An overview of the current operational data is provided here. All other menus can be accessed from this menu.

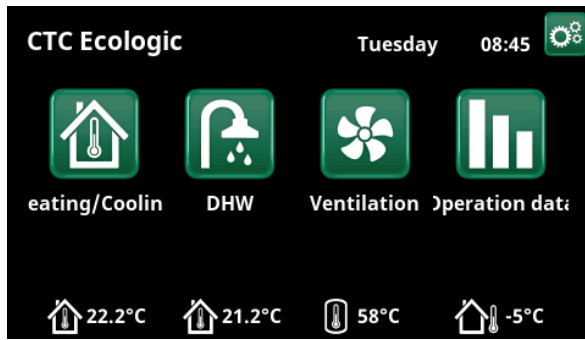

Main menu; the start page of the display.

Depending on which system is defined, the following symbols appear in the start menu, for example:



Heating / Cooling

Settings for raising or lowering the temperature indoors and for scheduling temperature changes. Submenus for "Active Cooling" are shown if defined.



DHW

Settings for DHW production.



Ventilation

Settings for ventilation mode if the system includes a separate ventilation unit.



Operation data

This shows current and historical operational data for the system.



Advanced

This is where the installer configures the settings and service for your system.



Indoor temperature

Displays the current indoor temperature for each heating circuit if room sensors have been installed.



Tank temperature

Shows the current temperature in the DHW tank.



Outside Temperature

Shows the outdoor temperature.

7.2 Installation wizard

When starting up the system and during reinstallation (see chapter “Advanced/Service”), a number of system selections must be made. The menu screens that are displayed are described below; the values shown are only examples.

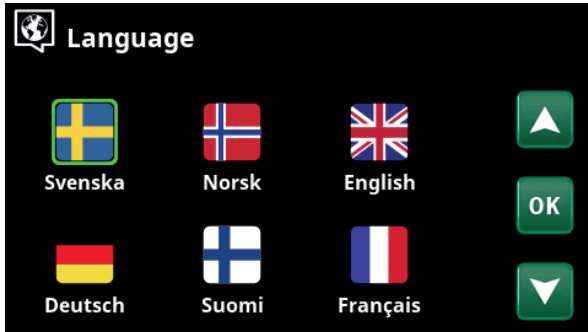

1. Choose language. Press OK to confirm.



2. Select the country where the heat pump is installed. Press OK to confirm.

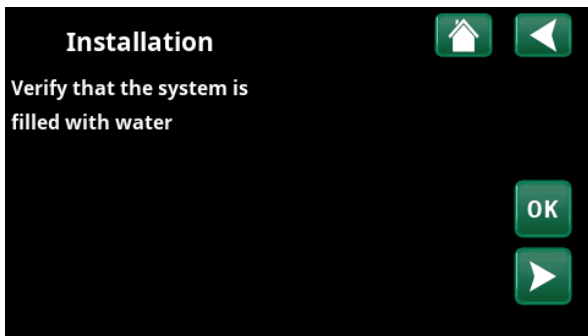

3. Verify that the system is filled with water. Confirm with "OK" and the "right" directional arrow.



4. Select the system type using the plus/minus (+/-) buttons. Confirm with the "right" directional arrow.

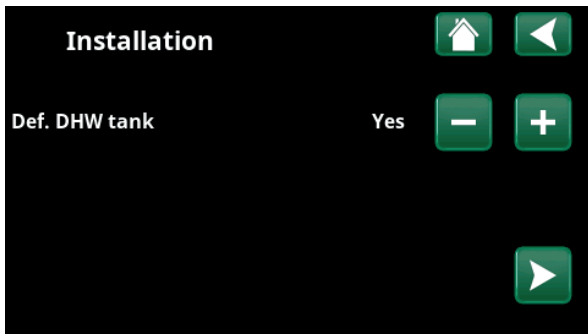

5. Use the buttons to define the DHW tank: For "Yes" press plus (+). For "No" press minus (-). Confirm with the "right" directional arrow.



6. Specify whether Heat pump 1 is permitted or blocked. For "Permitted" press plus (+). For "Blocked" press minus (-). Confirm with the "right" directional arrow.

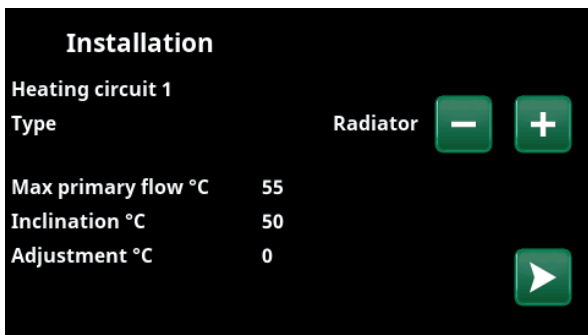

7. Specify whether heating circuit 1 applies to radiators or underfloor heating. Switch between "Radiator" and "Underfloor Heating" by clicking the (+) and (-) buttons. Confirm with the "right" directional arrow.

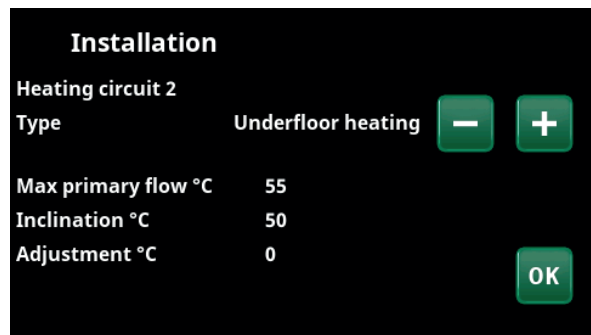

8. If Heating circuit 2 is defined, the corresponding menu for this system is displayed. Switch between "Radiator" and "Underfloor Heating" for Heating circuit 2 and finish the wizard with "OK".

7.3 Heating/Cooling



In the menu "HC- Heating/Cooling" the following settings can be made:

7.3.1 Setpoint setting with room sensor

Set the desired room temperature (set point) with the "minus" and "plus" symbols. In the example in the "HC1 Heating/Cooling" menu, the "Economy" programme and "Holiday mode" (V) are active for heating circuit 1.

In the "HC2 Heating/Cooling" menu, the "Cooling" mode is active.

"Holiday mode" and "Night reduction" only lower the room temperature when heating mode is active.

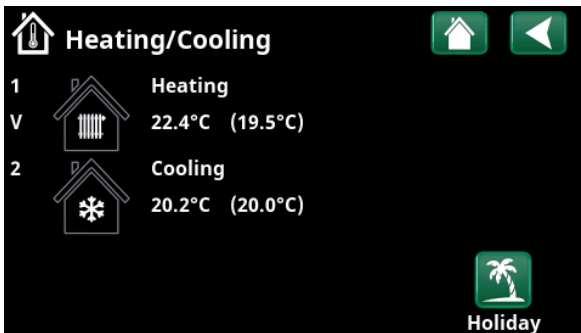

Click on heating circuit 1 or 2 to go to the menu of the respective heating circuit. In this menu you can activate "Holiday mode" for the heating circuits.

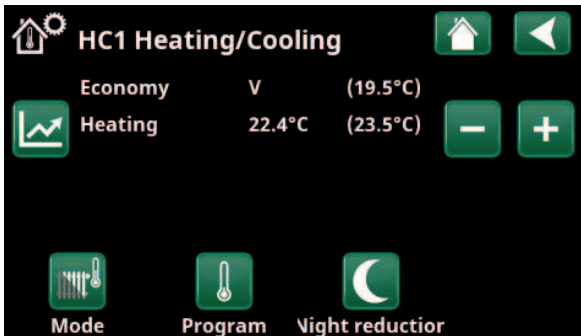

In the menu, programs "Economy" and "Holiday mode" (V) are active for heating circuit 1. In this example, both the "Economy" and "Holiday Mode" programmes are set to lower the set point (23.5 °C) by 2 °C, which means that the actual set point = 23.5 - 2 - 2 °C = 19.5 °C.

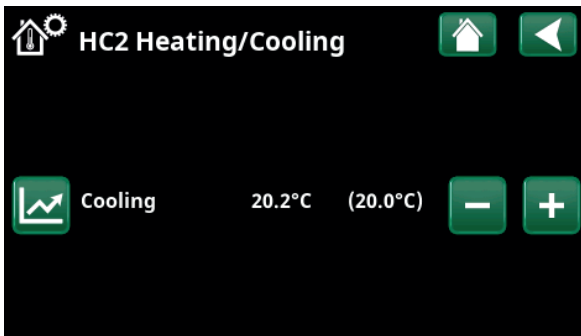

In the menu, "Cooling" (setpoint: 20.0 °C) is active for heating circuit 2. "Holiday mode" (V) does not lower the setpoint when cooling is active.

7.3.2 Program



Press the "Program" symbol and then the heating programme to be activated.

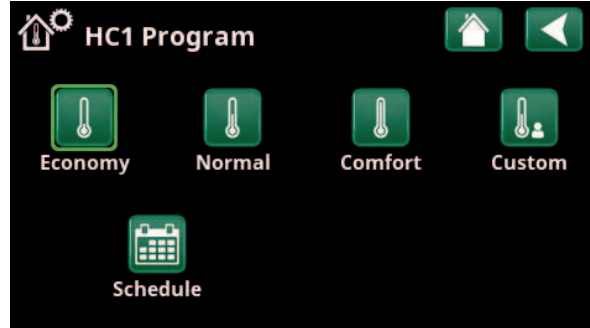

Menu "HC1 Heating/Cooling / HC1 Program" where program "Economy" has been activated.

Press and hold the symbol to go directly to the settings for the respective heating programs "Economy", "Comfort" and "Custom".

It is also possible to schedule the programs.

See chapter "Advanced/Settings/Heating circuit/Program" for information on how to set temperature increases/ decreases and delay times for the programs.

7.3.3 Heating/Cooling curve



Press the heating/cooling curve symbol in the "HC1- Heating/Cooling" menu. The graph of the heating/cooling curve of the heating circuit is displayed.

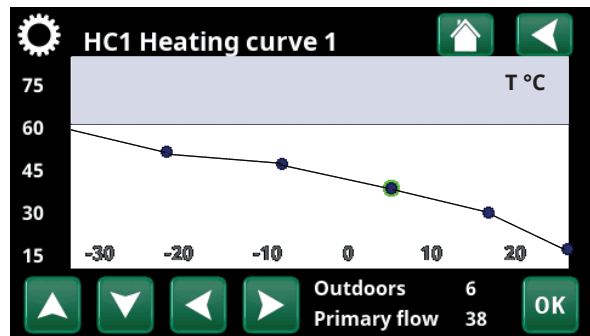

Menu "Heating/Cooling/HC1 Heating/Cooling".

The chapter "Advanced/Installation/Heating circuit" describes the setting of the heating/cooling curve.

See also chapter "House heating curve" for more information on adjusting the heating curve.

7.3.4 Heating mode



Press the "Mode" symbol and then select "Heating mode"; "Auto", "On" or "Off".

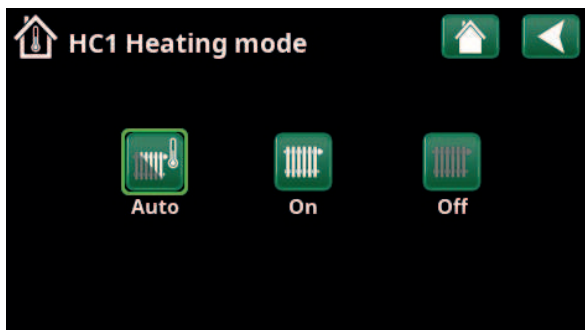

Menu "HC1 Heating/Cooling/HC1 Heating mode" where mode "Auto" has been activated.

Heating mode can also be selected in the menu "Advanced/Settings/Heating circuit/Heating mode".

See chapter "Advanced/Settings/Heating circuit" for more information.

7.3.5 Room temperature setting without room sensor

You can select "Room sensor - No" in the "Advanced/Define/Heating circuit" menu.

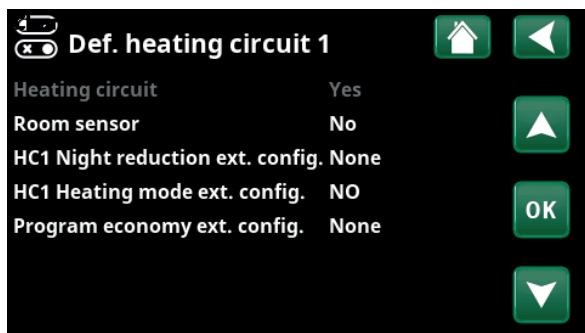

Menu "Advanced/Define/Heating circuit/Heating circuit 1".

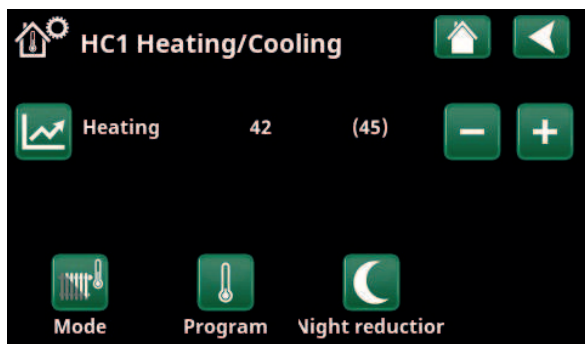

Menu "Advanced/Define/Heating circuit/Heating circuit 1". The heating circuit has no room sensors. The setpoint (primary flow temperature 45 °C) is shown in brackets, the current primary flow temperature 42 °C is shown to the left of the setpoint.

This is used if the room sensor is difficult to place, if the underfloor heating system control has its own room sensor or if you are using a wood-burning stove/fireplace. The alarm LED on the room sensor works as usual.

If a wood-burning stove or fireplace is used sporadically, the burning may cause the room sensor to reduce the temperature of the heating circuit and it may become cold in the rooms in other parts of the house. The room sensor can then be temporarily switched off during firing and the heat pump provides heat to the heating circuit according to the set heating curve. The radiator thermostats are throttled in the part of the house where the fire is burning.

If the room sensor has not been installed, the heating must be set according to the chapter "House heating setting".

7.3.6 Outdoor sensor/room sensor errors

If a fault occurs with an outdoor sensor, the product triggers an alarm and an outdoor temperature of -5 °C is simulated so that the house does not get cold.

If a fault occurs with a room sensor, the product triggers an alarm and automatically switches to operating according to the set curve.

7.3.7 Night Reduction Temperature



Night reduction means reducing the temperature indoors, via remote control or during scheduled periods.

In the menu "HC1 Night reduction" menu, the periods during the week for night temperature reduction can be scheduled.

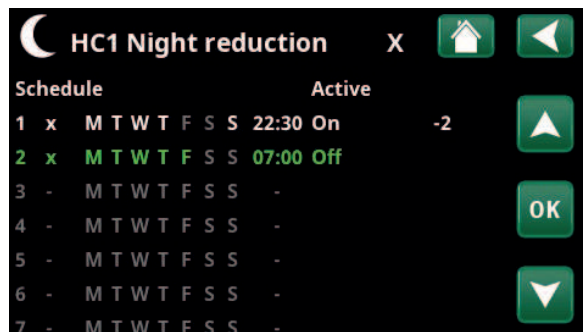

The schedule has been set for "Night Reduction" to be active weekdays between 22:30 and 07:00, except during the night between Friday and Saturday and the night between Saturday and Sunday (when no night reduction occurs).

The "Night reduction" icon in the "Heating/Cooling" menu only appears if a "Schedule" has been defined for the heating circuit in the "Advanced/Define/Remote control" menu.

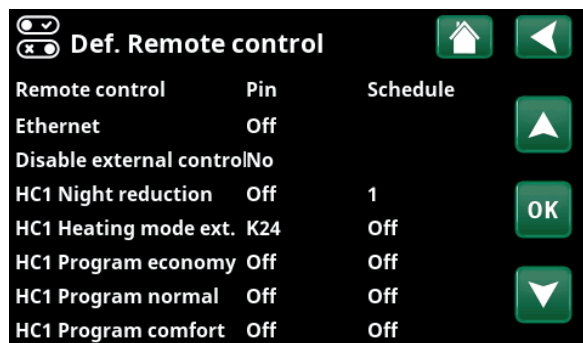

Menu: "Advanced / Define / Remote Control". The "HC1 Night Reduction" function is assigned to Schedule #1.

The "Schedule" chapter describes how to set schedules.

The value by which the temperature is reduced during remote control of the night reduction is set in one of the following menus.

Room sensor installed:

"Advanced/Settings/Heating circuit/Room temp reduced night red °C".

Room sensor not installed:

"Advanced/Settings/Heating circuit/Prim. flow reduced night red °C".

● When both "Night Reduction" and "Holiday Reduction" are in use, "Holiday Reduction" supersedes "Night Reduction".

● When holiday is enabled, hot water production is stopped. The "Temporary extra DHW" feature is also stopped.

7.3.8 Holiday



Here you set the number of days you want the set temperature to be lowered, for example if you go on holiday.

The holiday period can be set in number of days or you can schedule the holiday with start/end date and time.

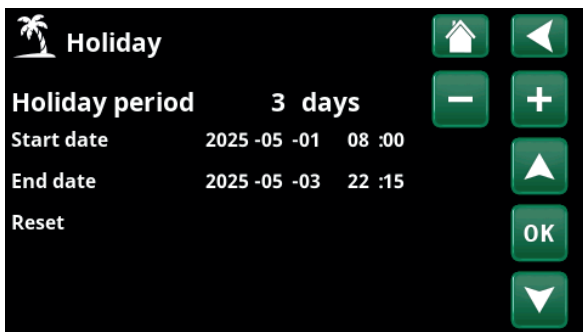

Menu "Heating/Cooling / Holiday".

Holiday period 0...300 days

Click on the "+" sign to set the number of days. The period is activated directly with date and time.

Start/End date

Set the date and time using the arrows.

NOTE! The number of days is displayed as 0.

Reset

Resets the holiday period to zero.

The number of degrees by which the temperature is lowered during the period is set in one of the menus:

Room sensor installed:

"Advanced/Settings/Heating circuit/Room temp reduced holiday °C".

Room sensor not installed:

"Advanced/Settings/Heating circuit/Prim. flow reduced holiday °C".

7.4 DHW



This menu is used to set the hot water comfort level and "Extra DHW".

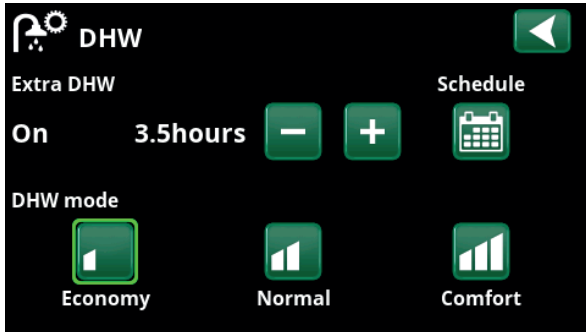

The "Extra DHW" function is set to be active for 3.5 hours.

Extra DHW

The "Extra DHW" function can be activated here. When the function is activated (by setting the number of hours using the plus sign in the "Hot Water" menu), the heat pump immediately starts to produce extra DHW. It is also possible to remotely control or schedule hot water production according to specified times.

Tip: Set the time approx. 1 hour earlier than when you need the hot water as it may take some time to heat.

DHW mode

You set the values for this option which apply to the heat pump's normal operation. There are three modes:



Economy

For low hot water needs.
(Factory setting stop temperature DHW tank: 50 °C).



Normal

Normal hot water needs.
(Factory setting stop temperature DHW tank: 55 °C).



Comfort

For high hot water needs.
(Factory setting stop temperature DHW tank: 58 °C).

Tip: Set to "Economy" mode from the start. If the hot water is deemed insufficient, raise to "Normal" mode, and so on.

Press and hold the button to go directly to the settings for the respective hot water programs "Economy", "Comfort" and "Custom".

7.4.1 Extra DHW

You can use this menu to schedule periods during weekdays when you want extra DHW. This schedule is repeated every week.

The stop temperature for Extra DHW is 60 °C (factory setting).

The "Weekly Program" chapter describes how to set schedules.

Click the "Extra DHW" heading to obtain a graphical overview of when the weekly program is active during weekdays.

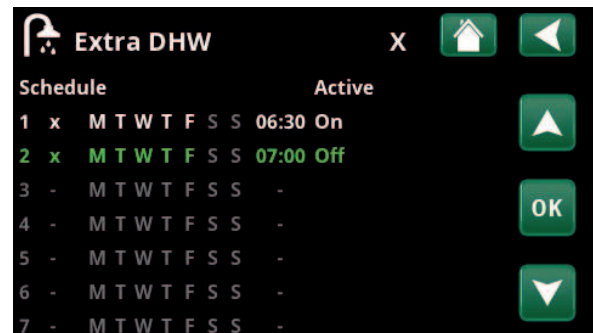

The "Extra DHW" function is set to be active on weekdays between 06:30 and 07:00.

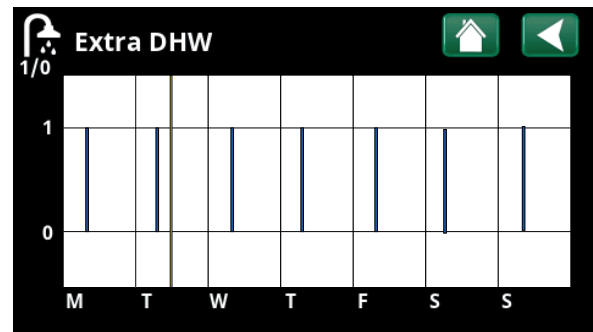

Use the Back button to switch between settings and preview. A vertical blue bar indicates when "Extra DHW" is active. A horizontal yellow line indicates the current time. The X axis represents the days, Monday to Sunday.

7.5 Ventilation



If the system includes a separate ventilation unit (defined in the "Advanced/Define/Ventilation" menu), you can select one of four ventilation modes and set a schedule in this menu.

The exhaust fan speed (10%-100%) for the four ventilation modes ("Reduced", "Normal", "Forced" and "Custom") can be set in the menu "Advanced/Settings/Ventilation".

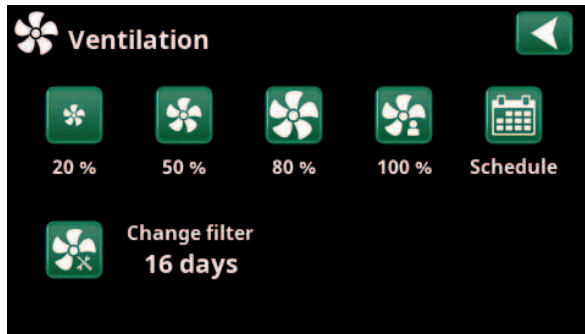

"Ventilation" menu.

Scheduling is possible for all ventilation modes. Refer to the "Weekly Program" chapter to learn about programming schedules.

For more information on the CTC EcoVent ventilation product, refer to the "Installation and Maintenance Manual".

7.6 Schedule

In a Schedule, the periods can be set for when a function should be active or inactive during the weekdays.

The system does not allow certain functions to be active at the same time on the same schedule; for example, the "Night Reduction" and "Extra DHW" functions, but most functions can share the same schedule.

If several functions share the same schedule, changes to the schedule for one function will cause the same changes for the other functions that share the schedule.

To the right of the schedule header, an "X" will appear if the same schedule is also shared by another remote control function.

Click on the schedule's header row to see a graphical overview of when the schedule is active during the days of the week.

7.6.1 Defining a schedule

In this example, a night temperature reduction of heating circuit 1 (HC1) is programmed.

First, a schedule must be defined in the "Advanced/Define/Remote control" menu.

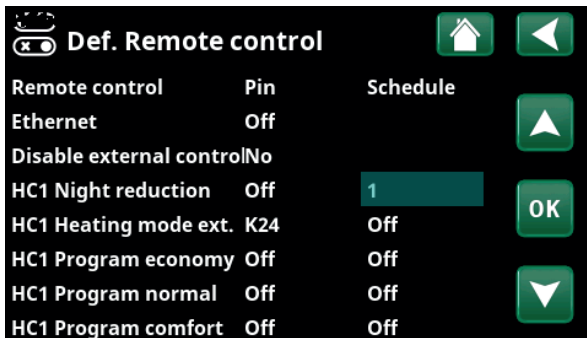

Menu "Advanced/Define/Remote Control".
The "HC1 Night Reduction" function is assigned to Schedule #1.

Enter a schedule (1-20) in the "Schedule" column in the "HC1 Night Reduction" row using the arrow keys, or click where the cursor is in the example.

7.6.2 Schedule settings

A schedule can be set for most remotely controlled functions in the menus under "Advanced/Settings".

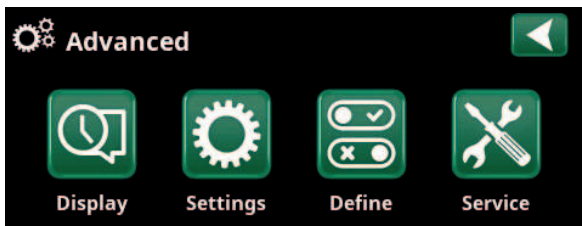

Menu "Advanced".

The schedules for "Extra DHW" and "Ventilation" can be accessed from the start page.

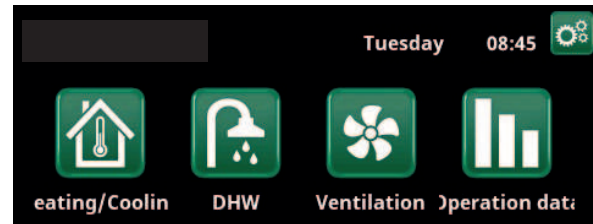

Main menu; the start page of the display.

The schedules for "Night reduction" and "Holiday" can be accessed via the "Heating/Cooling" menu on the start page.



Click on the "Night Reduction" icon in the heating circuit "Heating/Cooling" menu to set the schedule.

The schedule includes 30 rows and a setting can be made in each row. For example, in one row you can set the date and time for the function to activate, and the time the function should deactivate in the row below.

In the example, "Night reduction" for heating circuit 1 has been set to be "On" from 22:30 to 07:00 on weekdays, except for weekends (Friday and Saturday nights).

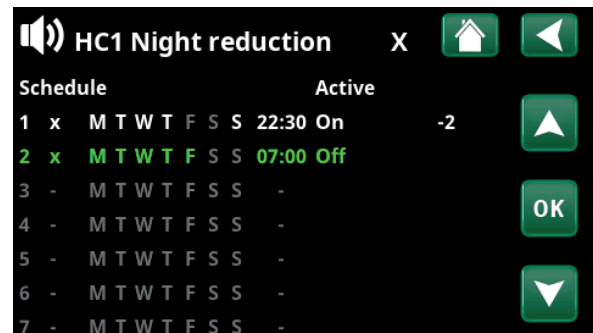

The schedule has been set for "Night Reduction" to be active weekdays between 22:30 and 07:00, except during the night between Friday and Saturday and the night between Saturday and Sunday (when no night reduction occurs).

The second row is highlighted green, which means that row is active at the current time.

Schedule (Active/Inactive/Restore factory settings)

Activate the schedule by setting it to "Active" mode. It is also possible to restore factory settings.

7.6.3 Editing a schedule

Go down to the first row and press "OK" to enable editing mode.

Time

Use the arrow keys to change the time (hours and minutes, respectively).

Day by day

Use the arrow keys (up arrow /down arrow) to mark active days in bold.

Action Off (On/Off)

This normally indicates whether the row will switch the function "On" or "Off".

However, for the "Night Reduction" and "SmartGrid Schedule" functions, the following applies:

- In the schedule for "Night Reduction", the temperature reduction that will apply during the period is specified in °C here instead. When a temperature is specified (setting range -1 to -30 °C), the status of the row automatically switches to "On".

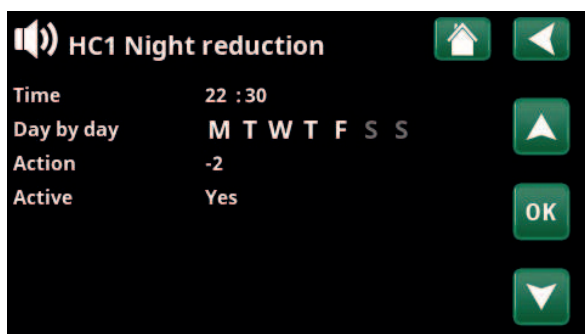

Setting the Night Reduction (-2 °C), weekday nights.

- When setting a "SmartGrid schedule", the SmartGrid function (SG Block., SG Low price and SG Overcapacity) is specified in the "Action" row. The status of the row automatically switches to "On".



The SmartGrid function "SG Low Price" is scheduled for weekdays 22:30-06:00. Go to the menu by selecting "SmartGrid schedule" in the "Advanced/Settings" menu.

Active Yes (Yes/No)

"Yes" means that the row is activated.



7.7 Operation data

The operation values shown in the menu screens are only examples.

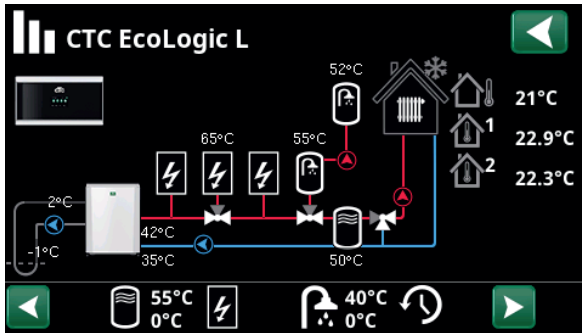

Main menu page for "Operation Data" with liquid-to-water heat pump CTC EcoPart connected. When the pumps are in operation, the pump icons also rotate on screen.

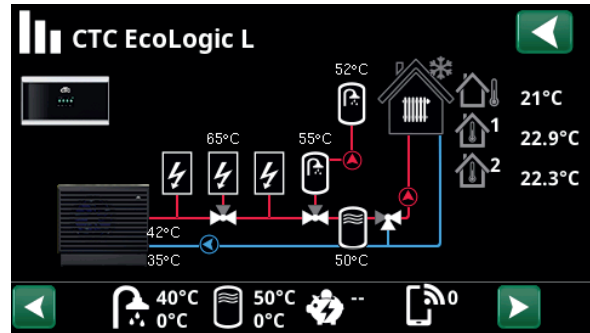

Main menu page for "Operation Data" with air-to-water heat pump CTC EcoAir connected. When the pumps are in operation, the pump icons also rotate on screen.



Outside temperature

Measured temperature, outdoor sensor.



Indoor temperature

Shows the room temperature for defined heating circuits (room sensors 1 and 2).



Brine temperature

Current temperature (2 °C) of the brine from the collector in the heat pump and return temperature (-1 °C) of the brine back into the collector hose.



Heating circuit

Current primary flow temperature (42 °C) to the house is shown on the left. Current return temperature (34 °C) is shown below.



Heat pump, air-to-water

The air-to-water heat pump is connected and defined for the circuit. The in and out temperatures of the heat pump are shown on the right.



Heat pump, liquid-to-water

The liquid-to-water heat pump is connected and defined for the circuit. The in and out temperatures of the heat pump are shown on the right.

The icon bar at the bottom of the menu page displays icons for additional functions or subsystems that have been defined.

Scroll using the arrows or swipe in the list if not all the icons fit on the page.

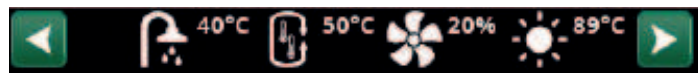

Ventilation



Pool



Solar collectors



El.prices



DHW



History



External buffer tank



External Boiler

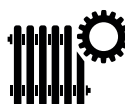

The gear icon is a shortcut to "Settings" for the respective part.



7.7.1 Operation data, Control unit

The menu shows general operating data.

Status **DHW**

Shows the different operating conditions of the system, see table below. NOTE! In a system with several heat pumps, each heat pump can have a different status. See "Status Heat pump" for current status.

Cooling tank °C* **0 (0)**

Shows current temperature (and setpoint) in the cooling tank.

Current L1/L2/L3 A **0.0 / 0.0 / 0.0**

Displays current in phases L1-L3 if current sensor installed. If not configured, only the highest value phase is displayed.

Degree minute **-61**

Shows current heat loss in degree minutes. Applies to System Types 1-3.

Delay additional heat* **180**

The menu displays the required delay in minutes of subnormal temperature in the buffer tank before additional heat E1 is started. Applies to System Types 4-6.

Cooling tank timer* **0**

Shows active delay (minutes) before cooling can be produced during heat production.

Degree minute cooling** **0**

Shows the current deficit of cooling in the heating system (measured in degree minutes). Applies to System Types 4-5.

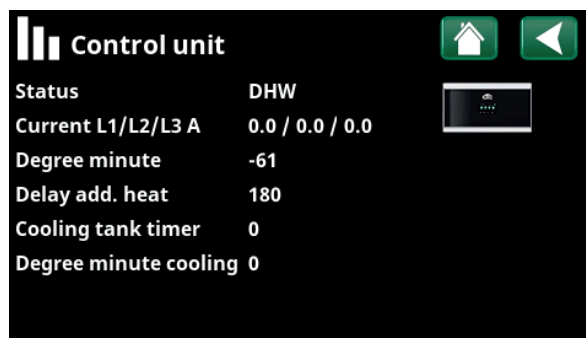

Menu Operation Data/Control Unit.

* The menu bar is displayed if active cooling is defined and when selecting "No" on the menu bar "Common tank, heating/cooling" in the menu "Advanced/Define/Cooling".

** The menu bar is displayed if active cooling is defined and when selecting "No tank" on the menu bar "Common tank, heating/cooling" in the menu "Advanced/Define/Cooling".

Control unit status	
DHW	DHW is produced.
Heating	Heat is produced for the heating circuit (HC).
Cooling	Cooling is produced for the heating circuit (HC).
Wood	Only shown for System Type 1. Shown if the wood boiler is producing heat. Wood operation is activated when the flue gas temperature exceeds the set value and the temperature is equal to or above its reference value (setpoint). When wood operation is active, the heat pump or additional heat is not used for heating. Wood operation is also activated when the primary flow sensor (B1) is 10 °C above the setpoint.
Heating-Mixing	Heat is produced for the heating circuit (HC). Mixing valve Y1 works according to the setpoint of the primary flow sensor. If the boiler temperature is 10 °C higher than the primary flow setpoint, mixing valve Y1 will begin to adjust down to this temperature.
DHW + Heating	DHW and heat are produced for the heating circuit (HC).
Off	No heating takes place.



7.7.2 Operation data, Heating circuit 1-*

Click on a heating circuit to see more detailed operation data in a new menu window.

Mode **Custom**

Shows the active DHW program.

Status **Heating**

Shows the operational status of the heating circuit, see the table below.

Primary flow °C **42 (48)**

Shows the temperature supplied to the current heating circuit and the setpoint in brackets.

Return flow °C **34**

Shows the temperature of the water returning from the heating circuit to the heat pump.

Room temp. °C **21 (22) (25)**

Shows the room temperature for the heating circuit if room sensor installed. In brackets, the setpoint is shown for the "Heating" and "Cooling" status.

Radiator pump **Off**

Shows the operational status of the radiator pump ("On" or "Off").

Mixing valve **Open <50%**

Shows whether the mixing valve "opens" or "closes" the heating or cooling flow to the heating circuit and when the mixing valve is in position "<50%" or ">=50%".

Which mixing valve is meant depends on whether heat or cooling production is defined and how cooling has been defined.

This menu bar is displayed for System Types 6 or if additional heat is connected via mixing valve Y1.

SmartGrid **Off**

Shows the status of the SmartGrid functions for the selected heating circuit.

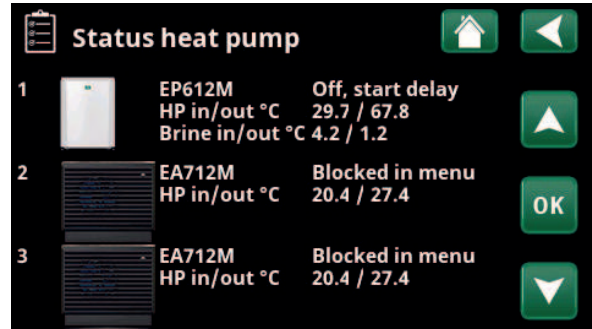

"Operation data, heating circuit" menu. The menu shows the current temperatures and status of defined heating circuits.

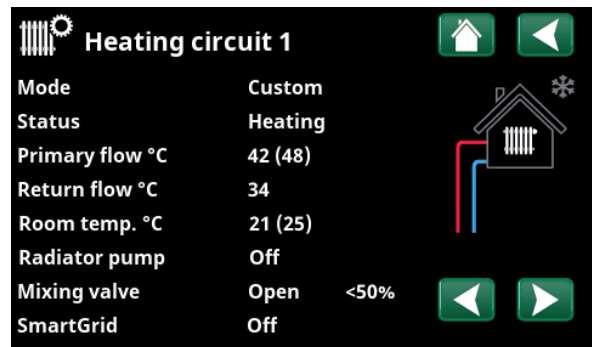

The menu shows detailed operation data for the selected heating circuit. Click the arrows or swipe in the menu to view defined heating circuits.

**The number of possible heating circuits or heat pumps that can be connected to the system varies depending on the control system.*

Heating circuit status	
Heating	Heating is produced for the heating circuit (HC).
Cooling	Cooling is produced for the heating circuit (HC).
Holiday	"Holiday reduction" of room temperature is active. For more information, refer to the "Heating/Cooling" chapter.
Night reduction	"Night reduction" of room temperature is active. For more information, refer to the "Heating/Cooling" chapter.
Off	No heating/cooling produced.

7.7.3 Heat pump status*

This menu appears when several heat pumps have been defined.

Status HP **Off, start delay**

Heat pump 1-3 can have the status according to the table below.

HP in/out °C **29.7 / 67.8**

Shows in/out temperatures from the heat pump.

Brine in/out °C **4.2 / 1.2**

Shown for liquid-to-water heat pumps.

Shows in/out temperatures of the brine.



Liquid-to-water heat pumps:

- CTC EcoPart 400
- CTC EcoPart 600M**
- CTC EcoPart 7000**



Air-to-water heat pumps:

- CTC EcoAir 400
- CTC EcoAir 600M**
- CTC EcoAir 700M**



CTC EcoAir C100**

** Modulating heat pumps

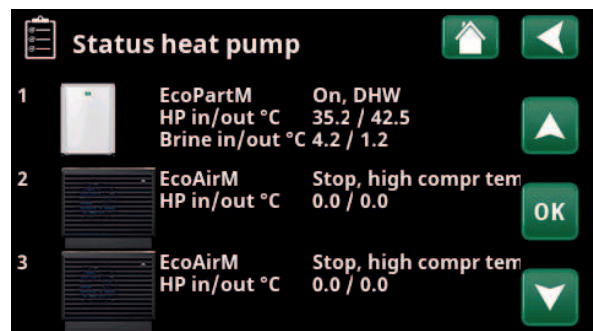

The menu shows the status and operating temperatures of defined heat pumps.

**The number of possible heating circuits or heat pumps that can be connected to the system varies depending on the control system.*

Status heat pump (example)	
Blocked in menu	The heat pump's compressor is "Blocked" in the "Advanced/Settings/Heat Pump/Heat pump 1" menu*.
Communication error HP	The control unit cannot communicate with the heat pump.
On, DHW	The heat pump heats the DHW tank.
Off, start delay	The heat pump's compressor is off and is prevented from starting due to the start delay.
Off, start ready	The heat pump's compressor is off but ready to start.
Flow on	Displayed if there is flow in the charging coil.
On, cooling	The heat pump is producing cooling for the heating circuit
On, heating	The heat pump is producing heat for the heating circuit.
Defrost	The heat pump defrosts. Displayed for air-to-water heat pumps:
Stop, low outdoor temp	Outdoor temperature lower than min. limit - air-to-water heat pump only.
Stop, high outdoor temp	Outdoor temperature higher than max. limit - air-to-water heat pump only.
Blocked	The heat pump has stopped due to a temperature or pressure that has exceeded its maximum value.
Off, alarm	The compressor is off and gives an alarm signal.
Stop, tariff	The compressor is blocked due to the remote control function being active.



7.7.4 Operation data, Compressor HP

Status **On, heating**

Displays the heat pump status, see examples of status modes in the "Status, heat pump" menu.

Model* **EP412**

Shows the heat pump model.

Compressor **65RPS R**

Shows the compressor speed. "R" stands for "Reduced Mode" (for example, during "Silent Mode").

Charge pump **On 78%**

Shows operating status of the charge pump ("On" or "Off") and the flow in percent (0-100).

Brine pump **On 50%**

Shows operating status of the brine pump ("On" or "Off") and the speed in percent.

This menu bar is displayed for liquid-to-water heat pumps.

Brine in/out °C **4.0 / 1.0**

This shows the brine pump's incoming and outgoing temperatures.

This menu bar is displayed for liquid-to-water heat pumps.

Fan **On 80%**

Shows operating status of the fan ("On" or "Off") and the fan speed in percent.

This menu bar is displayed for air-to-water heat pumps.

Compressor heater **Off**

Displays the operating status of the compressor heater ("On" or "Off").

Applies only to CTC EcoAir 700M/CTC EcoAir C100.

HP in/out °C **35.0 / 42.0**

Shows the heat pump's incoming and outgoing temperatures.

Flow l/min **0.0**

Shows flow to/from the heat pump.

Outdoor temp °C **3.5**

Shows the outdoor temperature on the sensor located on the heat pump.

This menu bar is displayed for air-to-water heat pumps.

Current A **9.8**

This menu bar is displayed depending on heat pump model.

AC Choke °C **75.0**

Shows the temperature of the heat pump AC choke.

This menu bar is displayed for liquid-to-water heat pump CTC EcoPart 600M/CTC EcoPart i600M/CTC EcoPart 7000.

Compressor temp °C **0.0**

Shows the temperature in the compressor.

Software HP PCB **20230301**

Shows the heat pump software version.

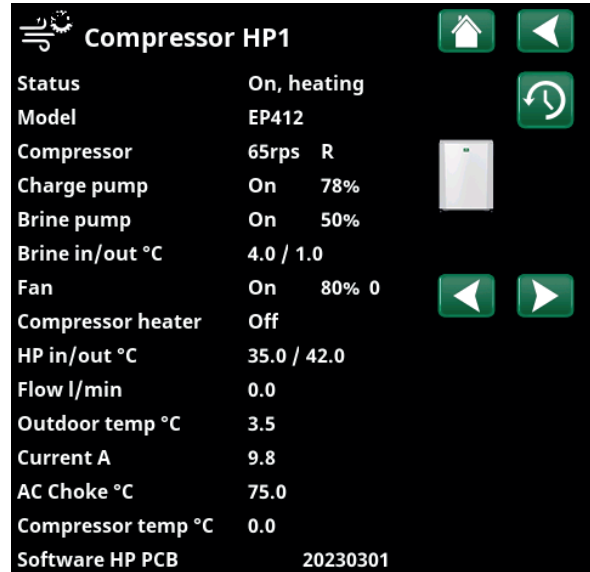

The menu shows detailed operation data of the selected heat pump. If the system includes several heat pumps, click the desired heat pump in the "Status heat pump" menu to access this menu.

**The number of possible heating circuits or heat pumps that can be connected to the system varies depending on the control system.*



7.7.5 Stored operation data

This menu shows accumulated operating values.

The operating values shown in the menu screens are only examples. The operating data displayed varies depending on the language selected.

Total operation time h **3500**

Shows the total time the product has been powered.

Highest primary flow °C **51**

Shows the highest temperature that has been supplied to the heating circuit.

Energy el. total (kWh) **250**

Shows how much additional heat has been used.

Operation time /24 h:m **07:26**

Shows total operating time during the last 24 hours.

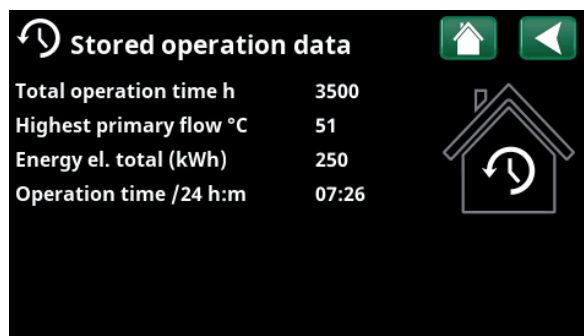

Menu: "Operation data/Stored operation data".



7.7.6 Operation data, Additional heat (E1-E3)

The menu shows additional heat sources (E1-E3) defined in the "Advanced/Define/System Type" menu.

When additional heat is active, the lightning flash in the icon shines red.

Select additional heat (E1-E3) for detailed operation data.

System status DHW

Shows the various operational statuses of the system. See table below.

Additional heat (E1) On

Shows the operating mode ("On" or "Off") for additional heat.

Boiler/out °C 79 / 24

Shows the boiler temperature and the temperature after the mixing valve.

Applies to System Type 1.

For status "DHW", the setpoint is shown in brackets, e.g. "24 (55)", in the following cases:

- DHW operating mode has been set ("Normal", "Economy" or "Comfort").
- In the "Advanced/Define/System Type" menu, the heat pump(s) must be defined in the "Heat pumps for DHW" row.
- The heat pump in the "Advanced/Define/Heat pump" menu must be set to "On".

Flue gas °C 150

Shows the temperature of the flue gas flow if wood operation is active.

Applies to System Type 1.

Mixing valve Opens

Displayed if the mixing valve for additional heat "opens" or "closes".

Mixing valve 50% Off

"On" means that the 4-way bivalent mixing valve is open to at least 50%.

Applies to System Type 6.

Degree minute -80

Shows the current degree minutes calculation for the additional heat source.

Applies to System Types 1-3.

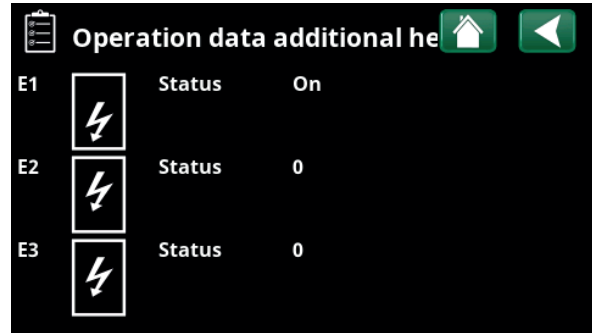

Click additional heat source (E1-E3) to view detailed Operation Data.

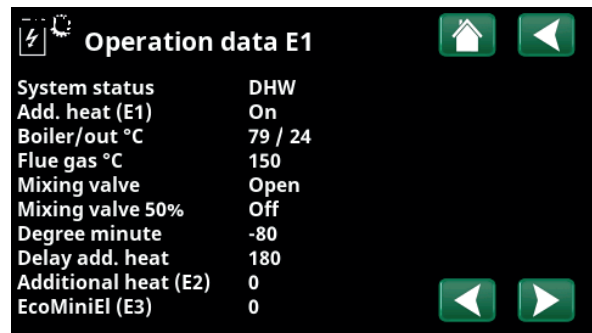

"Operation Data E1" menu. The example also shows menu bars for additional heat E2 and E3.

Delay additional heat 180

The menu displays the required delay in minutes of subnormal temperature in the buffer tank before additional heat E1 is started.

Applies to System Types 4-6.

Additional heat (E2) 0

Shows the output signal (0-10V) or how many steps (0-1, 0-3 or 0-7) of E2 are active.

EcoMiniEI (E3) 0

Shows the number of output stages (1-3) for additional heat E3 that are active.

Control unit status	
DHW	DHW system charging.
HC	Heating circuit charging.
Wood	Wood operation active. Only shown for System Type 1.
Heating-Mixing	Refer to the "Operation Data/Control System" chapter. Applies to System Type 1.
DHW + Heating	DHW is produced and heat is produced for the heating circuit (HC).
Off	No heating takes place.



7.7.7 Operation data, DHW

Mode **Comfort**

Shows the active DHW program (Economy/Normal/Comfort).

DHW tank °C **45 (55) (55)**

Shows the current temperature in the DHW tank and the setpoint (in brackets) for heat pump operation and during additional heat operation.

When the Legionella protection function is active, "L" is displayed after the temperature values.

Extra DHW **On**

"On" means the "Extra DHW" function is active.

DHW circulation **Off**

"On" means the "DHW circulation" function is active.

SmartGrid **Off**

The status of the SmartGrid functions for DHW is shown here.

External DHW tank °C **45**

Shows the temperature in the external DHW tank (if defined).

When the Legionella protection function is active, "L" is displayed after the temperature value.

Pump ext. DHW tank **On**

Displays the status ("On"/"Off") of the charge pump for the external DHW tank (if defined).

Status E4 **Off**

Shows the operational status for additional heat E4 in the DHW tank.

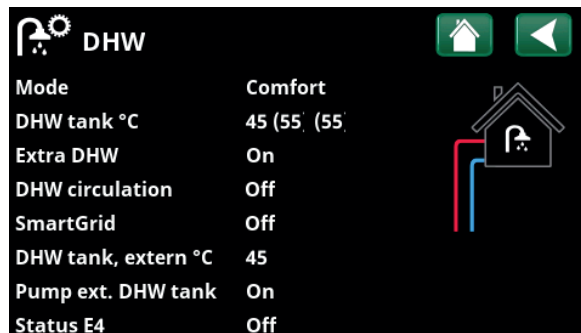

"Operation data/DHW" menu.



7.7.8 Operation data, Buffer tank

This menu is displayed if "Buffer Tank" has been defined in the "Advanced/Define/Buffer tank" menu.

System status **Off**

Shows the various operational states of the system, see table below.

Temperature °C **50 (56)**

Shows the temperature in the buffer tank and the setpoint that the system is working to achieve.

Remote control **Off**

"On" means that buffer tank heating is taking place because the weekly program or external control is activated.

SmartGrid **Off**

The status of the SmartGrid functions for buffer tank (Off / SG Low Price / SG Overcapacity) is shown here.

Additional heat (E1) **Off**

Here you can see if the additional heat is "On" or "Off".

Delay additional heat **0**

Here you can see the time (minutes) before the additional heat (E1) goes to the "On" position.

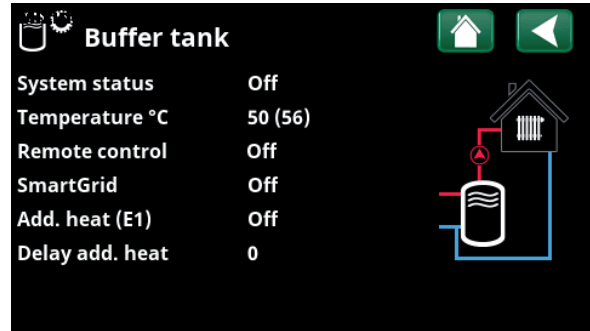

"Operation Data/Buffer Tank" menu.

Status Buffer tank	
DHW	The buffer tank is charging the DHW system.
HC	The buffer tank is charging the heating circuit.
Wood	Wood operation active. Only shown for System Type 1.
Heating-Mixing	Refer to the "Operation Data/Control System" chapter. Applies to System Type 1.
DHW + Heating	The buffer tank charges the domestic hot water (DHW) and heat to the heating circuit (HC).
Off	No heating takes place.



7.7.9 Operation data, Solar collectors*

This menu is displayed if "Solar collectors" have been defined in the "Advanced/Define/Solar collectors" menu.

Status **Charging DHW**

Shows status of solar collectors, see table below.

Outlet °C **68**

Shows the outgoing temperature from the solar collectors.

Inlet °C **60**

Shows the incoming temperature to the solar collectors.

Solar collector pump % **46%**

This shows the actual percent of maximum capacity for the circulation pump.

Charge pump, Solar collector % **46%**

This shows the actual percent of maximum capacity for the circulation pump.

Charging solar/tank **DHW**

This indicates whether the DHW tank or buffer tank is being charged.

Mixing valve **Close**

Shows whether the mixing valve "opens" or "closes".

Pump charge brine loop **Off**

This shows the operating mode for the pump ("Off" or "On") for recharging the bedrock/ground.

Valve charge brine loop **Off**

This shows the operating mode for the valve ("Off" or "On") for recharging the bedrock/ground.

Energy output (kWh) **354**

Shows total (estimated) energy output.

Energy output /24h (kWh) **0.0**

Shows energy output in the last 24 hours.

Power (kW) **0.0**

Shows current power output.

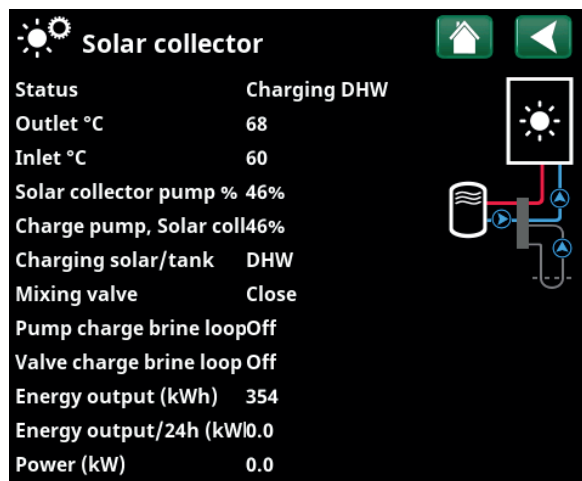

"Operation Data/Solar collectors" menu.

*Applies to CTC EcoLogic XL/L.

Status, solar collectors	
Solar collectors Off	Solar collectors are in operating mode "Off".
Charging Boiler	Solar collectors charging the wood boiler.
Charging DHW	Solar collectors charging the DHW system.
Charging Buffer tank	Solar collectors charging the buffer tank.
Vacuum panel test	Circulation through the solar collectors is started temporarily to check the panels' outgoing temperature.
Recharging bedrock/ground	Solar collectors recharging the bedrock/ground.
Panel cooling/Tank cooling/ Antifreeze panel	Displayed when any protection function has been activated.



7.7.10 Operation data, Pool*

This menu is displayed if the "Pool" has been defined in the "Advanced/Define/Pool" menu.

Status **Off**

Shows the current operating status ("On", "Blocked" or "Blocked Externally").

- "Blocked" means that pool heating has been blocked from the "Advanced/Settings/Pool" menu.
- "Blocked ext." means that the pool is externally blocked via remote control or weekly program.

Pool temp °C **21 (22)**

Shows the temperature in the pool and the setpoint that the system is working to achieve.

SmartGrid **Off**

The status of the SmartGrid functions for pool is shown here.

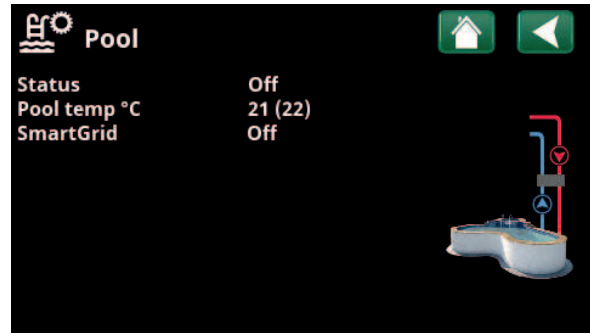

"Operation Data/Pool" menu.

*Applies to CTC EcoLogic XL/L.



7.7.11 Operation data, Cooling*

This menu is displayed if "Cooling" has been defined in the "Advanced/Define/Cooling" menu.

Cooling tank °C **18 (15)**

Shows the temperature in the cooling tank and the setpoint (in brackets) that the system is working to achieve.

Cooling tank upper/lower °C **18/16 (15)**

Shows the temperature in the upper/lower cooling tank and the setpoint (in brackets) that the system is working to achieve.

The menu is displayed when dual sensors are installed in the cooling tank.

Return temp, Brine °C** **16**

Shows the temperature in the brine loop after the heat exchanger.

Charging cooling tank temp °C** **15**

Shows the primary flow temperature to the cooling tank.

Diverting valve heat dumping** **Off (Off/On)**

This shows whether the diverting valve is "On" or "Off".

Diverting valve active cooling** **Off (Off/On)**

"On" means active cooling.

"Off" means passive cooling.

Pump, brine heat dumping** **80**

This shows the actual percent of maximum capacity for the pump to the heat dumping.

Charge pump, heat exch. cooling tank** **80**

This shows the actual percent of maximum capacity for the charge pump to the heat exchanger cooling tank.

Proportional diverting valve cooling** **100**

This shows the actual percent of maximum opening of the diverting valve for the brine.

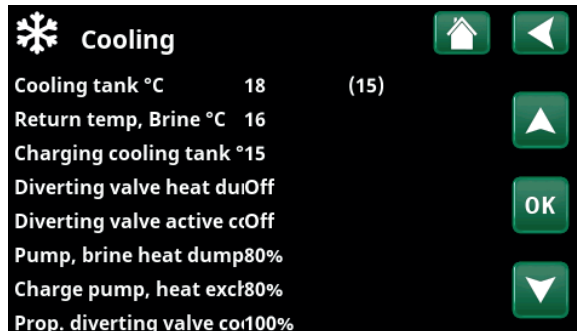

"Operation data/Cooling" menu.

*Applies to CTC EcoLogic L/XL.

**Only applies to CTC EcoLogic XL.



7.7.12 Operation data, Ventilation

This menu is displayed if the "CTC EcoVent" ventilation product has been defined in the "Advanced/Define/Ventilation/EcoVent 2x" menu.

For more information, see the Installation and Maintenance Manual for CTC EcoVent.

Mode **Reduced**

Shows the current ventilation mode.

Setting options: Reduced / Forced / Normal / Custom.

Fan **20%**

Fan speed in %.

Highest level RH **40**

Highest measured value for humidity (%).

Displayed if RH sensor from the CTC SmartControl series is installed.

Refer to the Installation and Maintenance Manual for the CTC SmartControl accessory.

Highest CO₂ **550**

Highest measured value for carbon dioxide (ppm).

Displayed if the CO₂ sensor from the CTC SmartControl series is installed.

Refer to the Installation and Maintenance Manual for the CTC SmartControl accessory.

Forced **Off**

"On" means the fan enters "Forced" ventilation mode.

Days to service filter **86**

This shows the time in days remaining until the filter change.

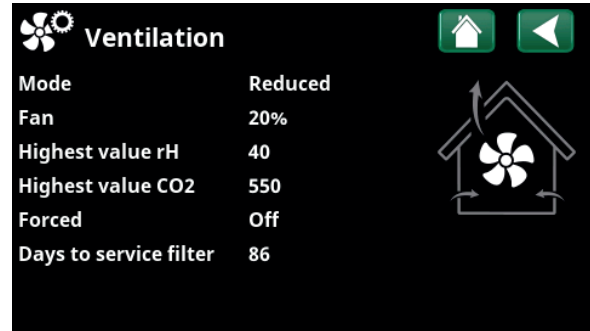

Menu: "Operation data/Ventilation".



7.7.13 Operation data, El.prices

This menu is displayed if "El.prices" has been defined in the "Advanced/Define/Communication" menu.

El.price mode **High**

Indicates the current price category ("High", "Medium" or "Low").

El.price/kWh **SEK 7.5**

Indicates the current electricity price in local currency.

Display the "Preview data" graph by clicking the "Graph icon" at the bottom-left of the menu screen.

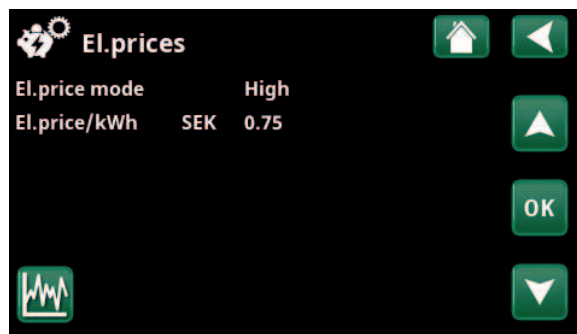

Menu: "Operation data/El.prices".

For more information and examples of Smart Electricity Price Control/SmartGrid, see the website www.ctc-heating.com/Products/Download.



7.7.14 External signal active

The menu shows the functions that are active via external control. The functions can be activated with:

- myUplink
- Virtuell digital in
- Modbus
- Relay
- SmartControl sensors

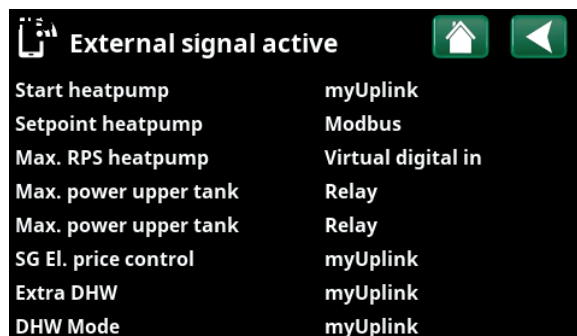

Menu: "Operation data/External signal active".

8. Advanced



This menu contains four sub-menus:

- Display
- Settings
- Define
- Service

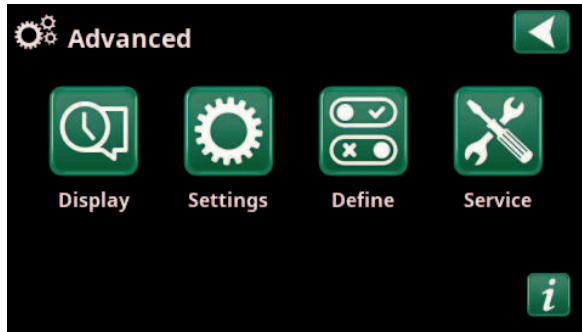

Menu: "Advanced".



For "System Information", click the "i" button in the lower right corner of the display in the "Advanced" menu. This displays the product serial number, MAC address, and application and bootloader versions. Click "Legal Information" to view information regarding third-party licences.

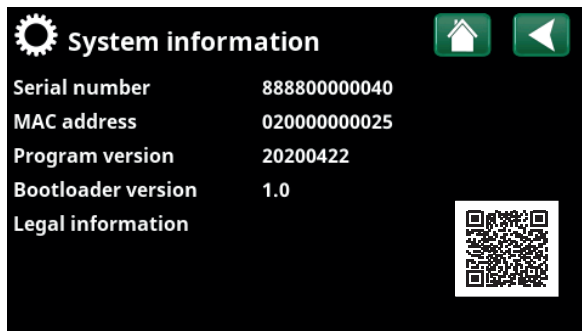

Menu: "Advanced/System information". To access this menu, click the "i" button in the lower right corner of the "Advanced" menu.

Scan the QR code with a tablet or smartphone. When your phone/tablet is connected to your local network, the product can be used with your device's touchscreen in the same way as the product's display.

8.1 Display



Time, language and other display settings can be carried out from this menu.

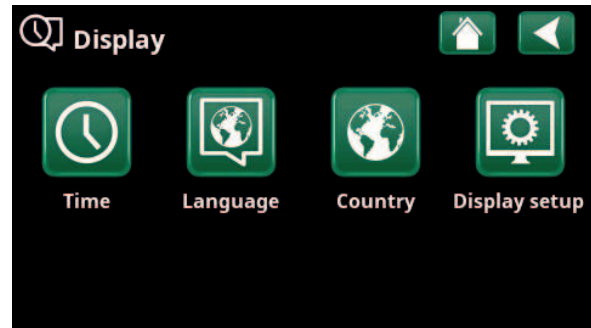

Menu: "Advanced/Display".

8.1.1 Time

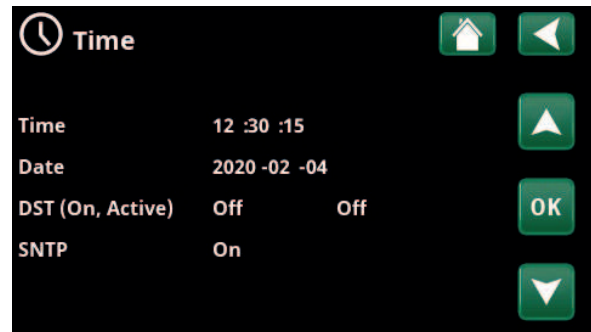

Menu: "Advanced/Display/Time".

Time and Date

Click on the time symbol. The menu can also be accessed by clicking the date or time in the upper right corner of the start page.

Press "OK" to highlight the first value and use the arrows to set the time and date.

DST (On, Active)

The left value can be set. "On" means the time is adjusted according to Summer Time.

The right value is fixed and shows the current status (for example, "Off" during the winter period). The display does not need to be connected to power for the values to be adjusted, since this occurs at the next start-up.

SNTP

Menu option "On" retrieves the current time from the internet (if online). More settings options can be found in the "Advanced/Settings/Communication/Internet" menu.

8.1.2 Language



Click a flag to select the language. The language selected is highlighted with a green square.

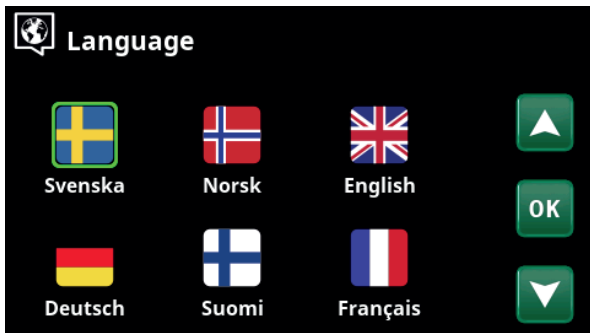

Menu: "Advanced/Display/Language".

To view more language options than those shown in the menu, scroll down the page, or press the down arrow key.

8.1.3 Country

Click on the "Country" symbol in the "Advanced/Display"



menu to display selectable countries and regions. The country that is displayed (highlighted in green) depends on which language has been selected.



Menu: "Advanced/Display/Country".

"English" is the default language setting, which means that "GB United Kingdom of Great Britain and Northern Ireland" is the default country setting.

Select the country where the plant is installed to get correct spot prices. Depending on which country is selected, product-specific factory settings may vary.

"Country" must also be selected to receive correct electricity prices when controlling electricity prices via the myUplink mobile app.

8.1.4 Display setup

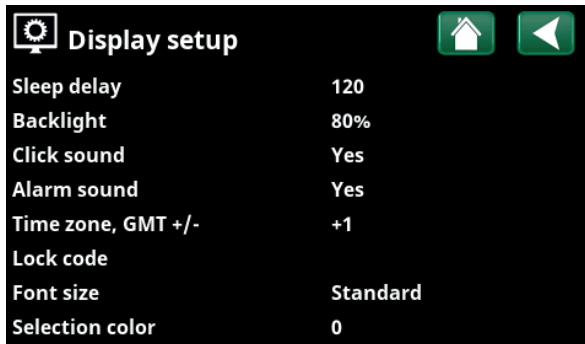

Menu: "Advanced/Display/Display setup".

Sleep delay 120 (Off, 1...360)

Enter the time in minutes before the display enters sleep mode if not touched. Settings can be applied in 10 min. intervals.

Backlight 80% (10...90)

Set the brightness of the backlit display.

Click sound Yes (Yes/No)

Enable or disable button sounds.

Alarm sound Yes (Yes/No)

Enable or disable alarm sounds.

Time zone, GMT +/- +1 (-12...14)

Set your time zone (relative to GMT).

Lock code 0000

Press "OK" and use the arrows to set a 4-digit lock code. If a lock code is set, it is shown as four stars. You will be prompted to enter the code when the display is restarted.

NB: Make a note of the lock code for your own reference when you enter it in the menu for the first time.

The serial number of the display (12 digits) can also be entered to unlock the display (enter '0000' + serial number); see chapter "Advanced/System Information".

The display can be locked by clicking the product name in the upper left of the start menu, whereupon you will be prompted to enter the lock code.

A lock code can be deleted by entering "0000" in this menu instead of the previously specified lock code.

Font size Standard (Small/Standard/Large)

The display's font size can be changed here.

Selection colour 0 (0/1/2)

Option to change the cursor background colour for clearer selection according to the light conditions.

8.2 Settings



Settings can be made here for, among other things, the house's heating and cooling needs.

It is important that the basic heating setting is right for your home. Values which are set incorrectly may mean that your property is not warm enough or that an unnecessarily large amount of energy is being used to heat your property.

i First define the desired functions, see "Advanced/Define". Settings are only displayed for enabled functions.

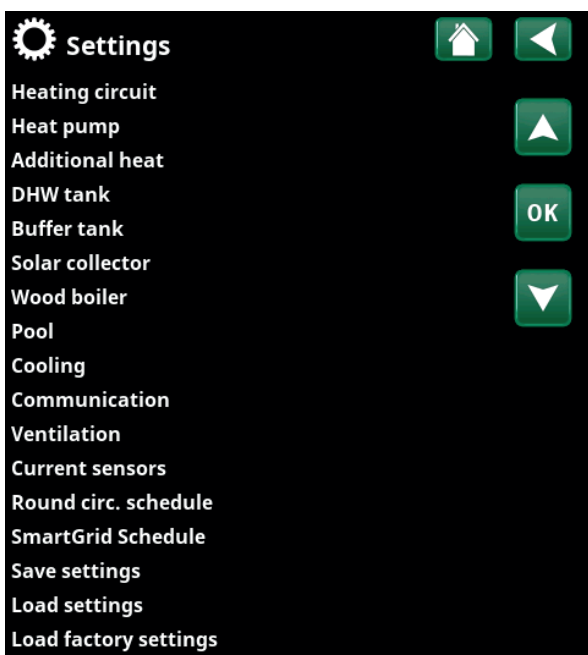

Menu: "Advanced/Settings".

8.2.1 Settings, Heating circuit*

In the "Settings" menu, select "Heating circuit" and then the heating circuit to be set.

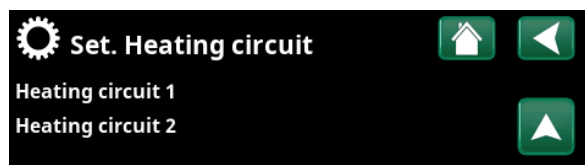

Menu: "Advanced/Settings/Heating circuit".

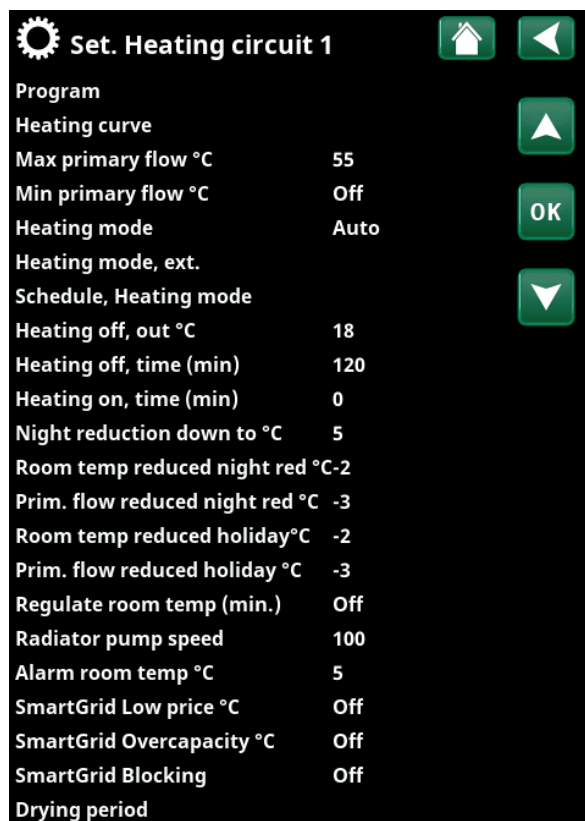

Menu: "Advanced/Settings/Heating circuit/Heating circuit 1".

*The heat pump can control up to four heating circuits.

Program

Press "OK" on the "Program" menu bar to make settings for the "Economy", "Comfort" and "Custom" heating programs. Selected programme is marked with an "X".

To activate a heating program or set a schedule, press the "Program" button from the "Heating/Cooling" menu, see chapter "Display settings".

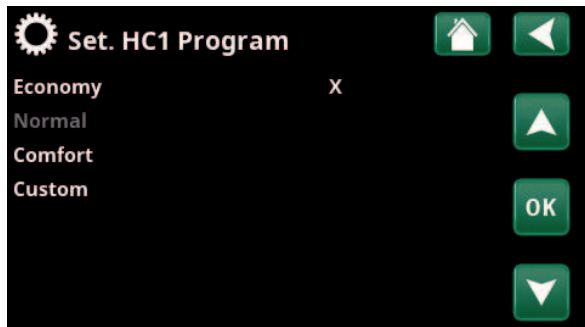

Menu "Advanced/Settings/Heating circuit/Heating circuit 1/Program".

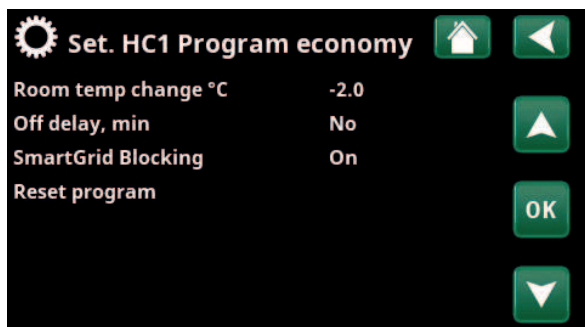

Menu "Advanced/Settings/Heating circuit/Heating circuit 1/Program/Economy".

• **Primary flow change °C** **-5 (-20...-1)**

The menu bar is displayed if the room sensor is not defined for the heating circuit. Setting "-5" (factory value program "Economy") means that the setpoint of the primary flow is lowered by 5 °C when the program is active.

• **Room temp change °C** **-2.0 (-5.0...-0.1)**

The menu bar is displayed if the room sensor is defined for the heating circuit. Setting "-2" (factory value program "Economy") means that the set setpoint for room temperature is lowered by 2 °C when the program is active.

• **Off delay, min** **No (No/10...600)**

Off delay means the time in minutes after the heating program "Economy", "Comfort" or "Custom" has been activated as the heating mode returns to the program "Normal".

However, if the "Custom" program is selected later than the "Normal" program, the "Custom" program will apply after the Off delay. The Off delay is adjusted in steps of 10 minutes for each key press (up or down arrow).

"No" means that the selected program will be activated until another heating program is activated.

• **SmartGrid Blocking*** **Off (Off/On)**

The menu bar is displayed when setting the heating programme "Economy" or "Custom".

"On" means that the heating program is activated when "SmartGrid Blocking" is active.

• **SmartGrid Low price*** **Off (Off/On)**

The menu bar is displayed when setting the heating programme "Comfort" or "Custom".

"On" means that the room temperature is increased according to the setting for "SmartGrid Low price °C" when "SmartGrid Low price" is active.

• **SmartGrid Overcapacity*** **Off (Off/On)**

The menu bar is displayed when setting the heating programme "Comfort" or "Custom".

"On" means that the room temperature is increased according to the setting for "SmartGrid Overcapacity °C" when "SmartGrid Overcapacity" is active.

• **Reset program**

Current program is reset with factory values.

**SmartGrid functions are set in the menu "Advanced/Settings/Heating circuit".*

Heating curve

The heating curve determines the primary flow temperature (and thus the indoor temperature) to the heating circuit at different outdoor temperatures.

See chapter "House heating settings" for more information on adjusting the heating curve.

Possible choices are "Set. heating curve", "Fine adjustment", "Active curve", "Copy from ..." and "Reset curve".

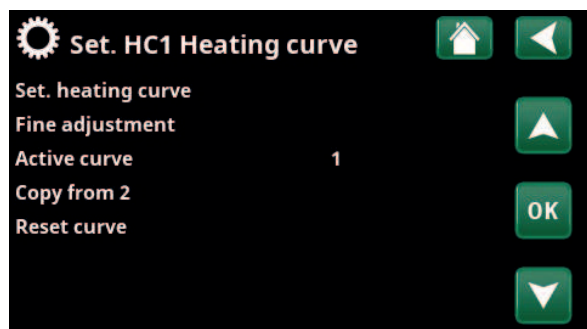

Menu "Advanced/Settings/Heating Circuit/Heating Circuit 1/Heating curve".

• Set. heating curve

The thicker line shows the factory-set curve while the thinner line shows the active heating curve to be reset.

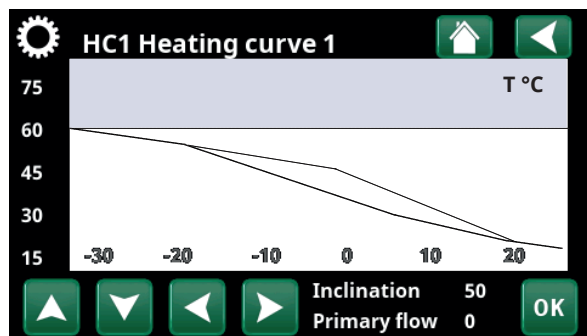

Menu "Advanced/Settings/Heating Circuit/Heating Circuit 1/Heating curve".

Here it is possible to adjust the appearance of the graph by adjusting the curve inclination and curve adjustment with the buttons below the graph. The adjustments you make here affect the entire appearance of the graph, while the changes made under "Fine adjustment" are made one point at a time. Curve inclination is adjusted with the left and right arrows while curve adjustment is adjusted with the up and down arrows. Confirm with "OK".

• Fine adjustment

The graph of the active heating curve for the heating circuit is displayed.

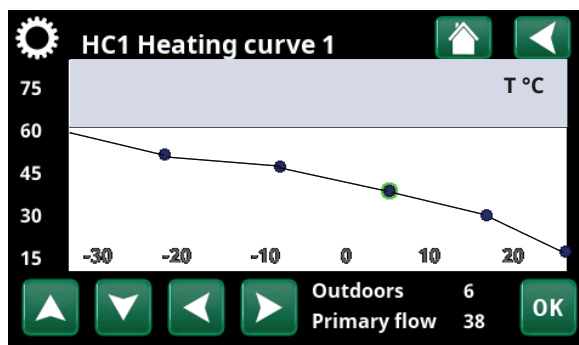

Menu "Advanced/Settings/Heating Circuit/Heating Circuit 1/Heating curve/Fine adjustment".

The heating curve can be adjusted in 5 points on the graph. Touch a point (becomes green) to change its position in the x-axis (outdoor temperature) and y-axis (primary flow temperature). Use the up/down/left/right buttons below the graph or press and drag the point.

Below the graph, the outdoor and primary flow temperatures for the selected point are shown. The heating curve can also be adjusted from the "Heating/Cooling" menu, see chapter "Display settings".

• Active curve 1 (1/2)

This menu bar shows the selected heating curve, it is possible to choose between two different heating curves per heating circuit.

• Copy from 1 (2)

The function "Copy from ..." is useful if you have created two different heating curve graphs but want to restore one graph to the same appearance as the other and then make changes.

Example: If heating curve 1 is selected as "Active curve", heating curve 1 will have the same appearance as heating curve 2 by selecting the line "Copy from 2" and pressing "OK". The menu bar cannot be selected (marked with gray) when heating curves 1 and 2 have the same values (the graphs look the same).

• Reset curve

Resets the active heating curve to the factory-set curve.

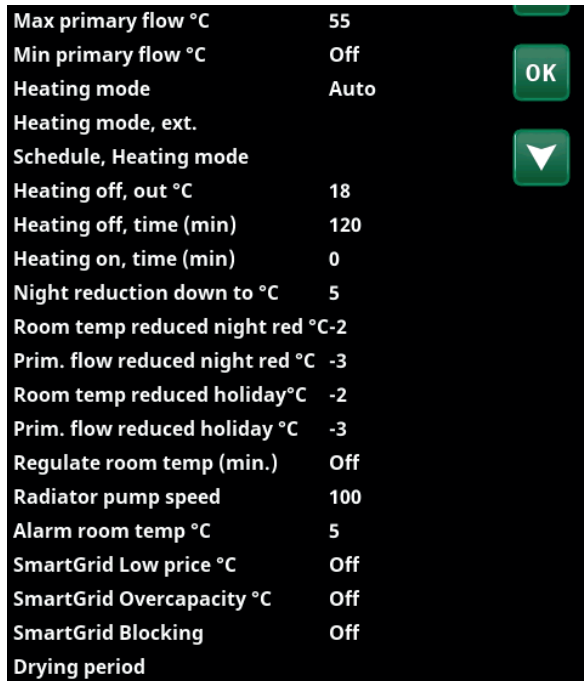

Menu: "Advanced/Settings/Heating circuit/Heating circuit 1".

Max primary flow °C **55 (30...80)**

Maximum permitted temperature supplied to the respective heating circuit.

Min primary flow °C **Off (Off/15...65)**

Minimum permitted temperature supplied to the respective heating circuit.

Heating mode **Auto (Auto/On/Off)**

Switching between heating season and summer mode can take place automatically (Auto) or a selection can be made here to set the heating to "On" or "Off".

Heating mode can also be selected from the start page by pressing the "Mode" button in the Heating/Cooling menu.

- **Auto** = switching the heating season On and Off carried out automatically.
- **On** = Continuous heating season, the radiator pump circulates constantly.
- **Off** = there is no heating, the radiator pump does not run (is turned over).

Heating mode, ext. **On (Auto/On/Off)**

The heating mode selected in this menu can be enabled/disabled externally.

This menu bar is displayed for the current heating circuit if a remote control input or a schedule has been defined for the function.

Read more in the "Def. Remote Control" section of the "Advanced/Define/" chapter.

Schedule, Heating mode

This menu bar is displayed if a schedule has been defined for the "Heating mode, ext." function in the remote control menu.

For more information, refer to:

- chapter "Schedule".
- section "Def. Remote Control" of the "Advanced/Define" chapter for defining the remote control function.

Heating off, out °C **18 (2...30)**

Heating off, time (min) **120 (30...1440)**

Heating on, time (min) **120 (30...1440)**

The menu bars can only be set if the "Auto" mode is selected in the "Heating mode" menu above. Otherwise, the menu bars are locked (greyed out).

When the outdoor temperature exceeds (or equals) the set value in the "Heating off, out °C" menu during the time (in minutes) set in the "Heating off, time (min)" menu, the production of heat for the house is stopped.

This means the radiator pump stops, and the mixing valve remains closed. The radiator pump is activated daily for a short period to prevent it from jamming. The system restarts automatically when heating is needed.

When the outdoor temperature drops to the limit where heating is needed again, heat to the house is permitted when the temperature falls below (or equals) the set value in the "Heating off, out °C" menu for the number of minutes set in the "Heating on, time (min)" menu.

Night reduction down to °C **5 (-40...40)**

When the outdoor temperature is lower than this, the "Night Reduction" function stops since too much energy is consumed and it takes too long to increase the temperature again.

This menu overrides remote control of "Night Reduction".

i If room sensors are installed, the "Room temp lowered..." menu is displayed. If there are no room sensors, the "Primary flow reduced..." menu is displayed.

Room temp reduced, Night red °C **-2 (0...-30)**

Room temp reduced, Holiday °C **-2 (0...-30)**

The menus are displayed if room sensors are installed for the heating circuit. The number of degrees by which the room temperature should be lowered during remote-controlled night reduction and during holidays can be set here. Night reduction can also be set periodically; the temperature decrease is then entered in the schedule.

Primary flow reduced, Night reduction °C **-3 (0...-30)**

Primary flow reduced, Holiday °C **-3 (0...-30)**

The menus are displayed if room sensors are not installed for the heating circuit. The number of degrees by which the primary flow temperature for the heating circuit should be lowered during remote-controlled night reduction and during holidays can be set here. Night reduction can also be set periodically; the temperature decrease is then entered in the schedule.

Example:As a general rule, a "Primary flow reduced" value of 3-4 °C is equivalent to a reduction of approximately 1 °C in room temperature in a normal system.

Regulate room temp (min.) Off (30...600)

At the selected time interval, the system senses the current room temperature and regulates to reach the setpoint.

The time interval is set individually for each property, depending on insulation and heat transfer (well insulated = longer time, poorly insulated = shorter time).

Radiator pump speed 100 (Off/1...100)

If radiator pump G1 is connected, this setting will be Off.

The purpose of this menu is to set the speed of the heat pump's charge pump G11.

The menu bar is displayed for System Type 1 as well as System Types 2 and 3 if there is no heat flow.

Alarm room temp °C 5 (-40...40)

If the room temperature is too low (according to the set value), the message "Alarm, low room temp." will be displayed. This menu bar is displayed if the room sensor is connected and defined.

SmartGrid Low Price °C 1 (Off, 1...5)

Setting to increase the room temperature at "Low price" energy price, via SmartGrid.

Both SmartGrid A and SmartGrid B must be defined in the remote control menu for this menu to be displayed.

Read more in the "Remote Control/SmartGrid A/B" section of the "Advanced/Define" chapter.

SmartGrid Overcapacity °C 2 (Off, 1...5)

Setting to increase the room temperature at "Overcapacity" energy price, via SmartGrid. This function is not used for electricity price control.

Both SmartGrid A and SmartGrid B must be defined with a remote control input for this menu to be displayed.

Read more in the "Remote Control/SmartGrid A/B" section of the "Advanced /Define" chapter.

SmartGrid Blocking Off (Off/On)

"On" means the heating circuit is blocked at "High" energy price, via SmartGrid. If the outdoor temperature falls below the value set in the "Night reduction down to °C" menu, this function is not activated.

Both SmartGrid A and SmartGrid B must be defined with a remote control input for this menu to be displayed.

Read more in the "Remote Control/SmartGrid A/B" section of the "Advanced /Define" chapter.

Drying period

Floor drying function for newly built properties. The function limits the calculation of primary flow temperature (setpoint) for "House heating settings".

For more information, see section "Def. Remote control" in chapter "Advanced/Define".

The floor drying function is scheduled and selected from 3 preset modes.

Create schedule

Fill in the wanted start date + time, select mode and temperature.

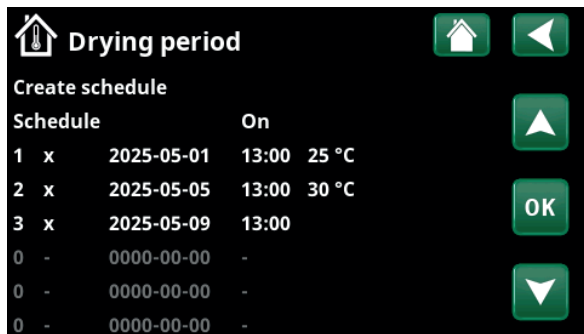

Menu "Advanced/Settings/Heating circuit/Heating circuit 1/Drying period".

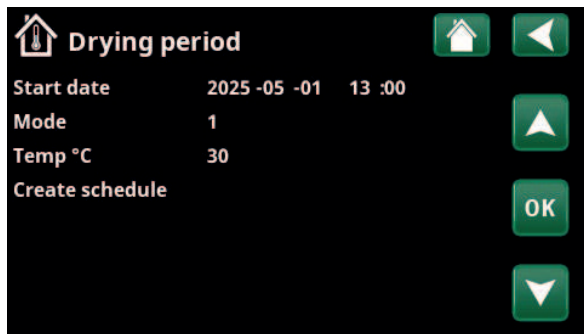

Menu "Advanced/Settings/Heating circuit/Heating circuit 1/Drying period/Create schedule".

• Mode 1: 8 days

1. The setpoint of the heating circuit is set to 25 °C for four days.
2. On days 5-8 the set value 'Temp °C' is used. From day 9 onwards, the value is automatically calculated according to the "House heating settings".

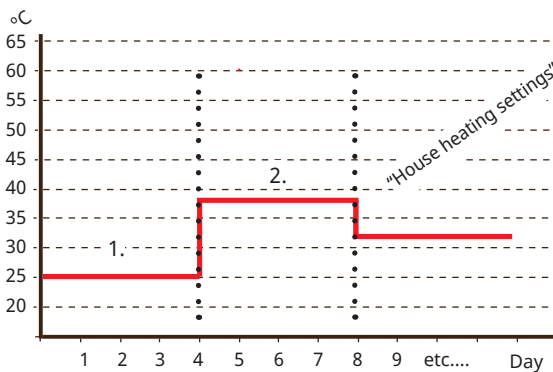

Example: Mode 1 with set value for "Temp °C": 38.

• Mode 2: 10 days + stepped increase and decrease

1. Stepped increase start: The setpoint of the heating circuit is set to 25 °C. Then the setpoint is increased by 5 °C every day until the setpoint is equal to 'Temp °C' (last step can be less than 5 °C).
2. Floor drying function for 10 days.
3. Stepped decrease: Setpoint is lowered to 25 °C by 5 °C per day (last step can be less than 5 °C). After stepped decrease and 1 day with setpoint 25 °C, the value is automatically calculated according to the "House heating settings".

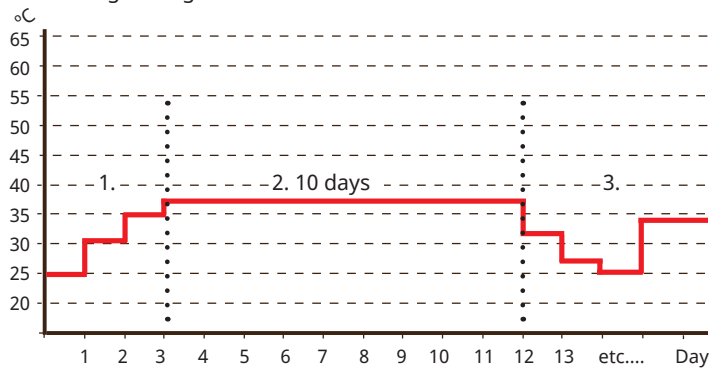

Example: Mode 2 with set value for "Temp °C": 37.

• Mode 3

This mode means that the function starts with "Mode 1", followed by "Mode 2" and then "House heating settings".

Temp °C 5 (25...55)

Set the temperature for "Mode 1/2/3".

Create schedule

Select "Create schedule" and confirm with "OK".

Schema Off (Off/On/Load factory settings)

Select "On" to activate a schedule.

Select "Load factory settings" to reset a schedule to zero.

The current period (schedule) is shown in green text.

Drying period (Heating circuit 2-) Off (Off/On)

The menu bar is displayed for heating circuit 2- if the floor function has been defined for heating circuit 1 as described above.

"On" means that the floor drying mode selected for heating circuit 1 will also run for the selected heating circuit.

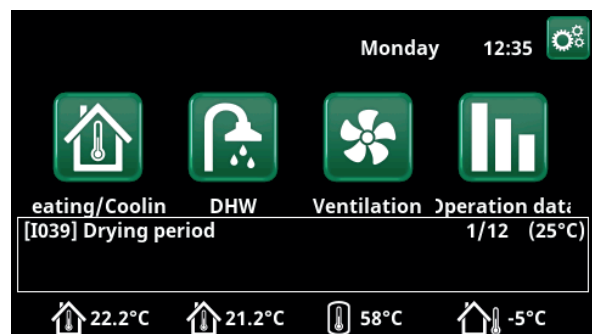

Example: Drying period day 1 of 12 with current set point of 25 °C.

8.2.2 Settings, Heat pump*

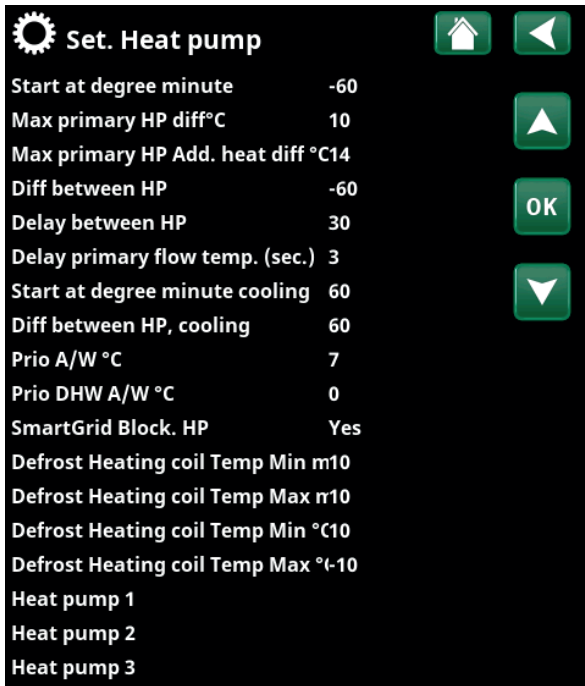

Menu: "Advanced/Settings/Heat pump".

Start at degree minute -60 (-900...-30)

The degree minutes at which Heat Pump 1 (HP1) will start is entered here. Degree minutes calculation is used only for System Types 1, 2 and 3.

Max primary HP diff °C 10 (3...20)

If the actual value for the primary flow is the same as the setpoint plus the set value and the degree minutes are less than the start value for the first heat pump (factory-set to -60), the degree minutes are set to the start value for the first heat pump.

If the actual value for the primary flow is greater than the setpoint plus the set value and the degree minutes are less than 0, the degree minutes are set to 0.

If the actual value for the primary flow is less than or equal to the setpoint minus the set value, the degree minutes are set to the start value for the first heat pump (factory-set to -60).

Applies to System Types 1, 2 and 3.

Max primary HP Add. heat diff °C 14 (5...20)

If the actual value for the primary flow is less than or equal to the setpoint minus the set value, the degree minutes are set to the highest set start value for the peak heat (factory-set to -500).

Applies to System Types 1, 2 and 3.

Diff between HP -60 (-200...-30)

This menu defines the difference (measured in degree minutes) at which the heat pumps will be started if necessary. During incrementing/decrementing using a smaller heat pump with lower output, half the set value is counted.

Applies to System Types 1, 2 and 3.

Delay between HP 30 (5...180)

The delay time between when two heat pumps can start is set here. This value applies, for example, to the amount of time that will pass before the third heat pump can start, when the first and second heat pumps are operating, and so on.

During incrementing/decrementing using a smaller heat pump with lower output, half the set value is counted.

Applies to System Types 4-6.

Delay primary flow temp. (sec.)*** 180 (20...300)

The charge temperature is high after DHW charging. During the set time period, the primary flow temperature is ignored.

Start at degree minute cooling** 60 (30...900)

The degree minutes at which the first cold-producing heat pump 1 should start producing cold is entered here.

Applies only to System Types 4 and 5.

Diff between comp. cooling** 60 (30...200)

This menu defines the difference (measured in degree minutes) that cooling-producing heat pumps must, if necessary, start producing cooling. During incrementing/decrementing using a smaller heat pump with lower output, half the set value is counted.

Applies only to System Types 4 and 5.

Prio A/W °C 7 (-20...15)

This temperature setting controls prioritisation during heat production between the air-to-water and liquid-to-water heat pumps if both types are connected to the system. The default value is 7 °C, which means that the air-to-water heat pump is prioritised for outside temperatures from 7 °C and warmer.

Prio DHW A/W °C 7 (-20...15)

This temperature setting controls prioritisation during DHW production between the air-to-water and liquid-to-water heat pumps if both types are connected to the system. The default value is 7 °C, which means that the air-to-water heat pump is prioritised for outside temperatures from 7 °C and warmer.

* The number of possible heating circuits or heat pumps that can be connected to the system varies depending on the control system.

** The menu bar is displayed if active cooling is defined and when selecting "No tank" on the menu bar "Common tank, heating/cooling" in the menu "Advanced/Define/Cooling".

*** This menu bar is displayed depending on heat pump model.

SmartGrid Blocking HP**No (No/Yes)**

"Yes" means that the heat pump is blocked when "SmartGrid Blocking" is active.

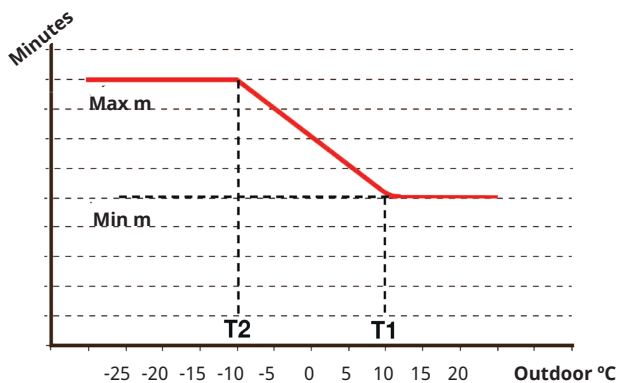

The diagram shows that the heating time of the heating coil to the condensation trays is regulated depending on the outside temperature.

When the outdoor temperature is below T2, the heating time adjusts up to "Max m".

When the outdoor temperature exceeds T2, the heating time adjusts down to "Min m".

These temperatures and times are set in the menus "Defrost heating temp..." on the left.

Defrost heating temp min m 10 (0...360)

Set the minimum heating time "Min m" (minutes) for the heating coil in the condensation tray at outdoor temperature T1.

Defrost heating temp max m 10 (0...360)

Set the maximum heating time "Max m" (minutes) for the heating coil in the condensation tray at outdoor temperature T2.

Defrost heating temp min °C 10 (-40...40)

When the outdoor temperature is this or higher (T1), the heating time is regulated down to the value set in the menu "Defrost heating temp min m".

Defrost heating temp max °C -10 (-40...40)

When the outdoor temperature is this or lower (T2), the heating time is regulated up to the value set in the menu "Defrost heating temp max m".

Heat pump 1-*

When installing more heat pumps, it is possible to produce heating/pool/domestic hot water and cooling simultaneously.

Apply settings for each heat pump. Refer to the "Settings/Heat pump 1-" chapter.

**The number of possible heating circuits or heat pumps that can be connected to the system varies depending on the control system.*

8.2.3 Settings, Heat pump 1-**

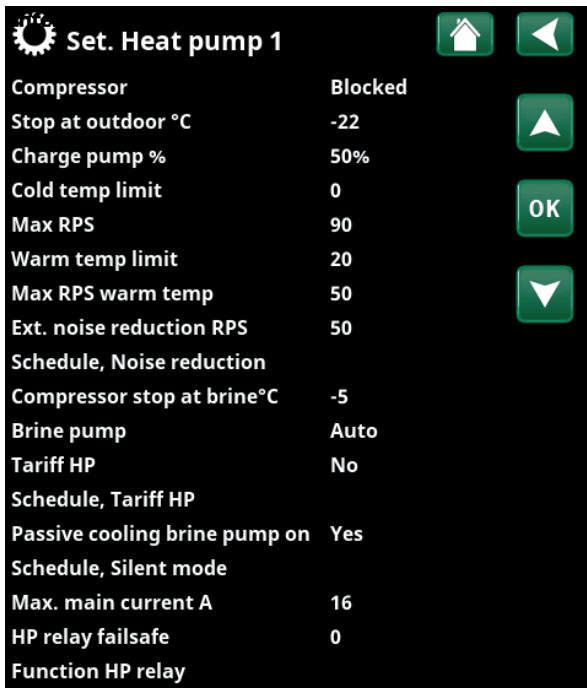

Menu: "Advanced/Settings/Heat pump/Heat pump 1-".

Compressor **Blocked (Permitted/Blocked)**

The heat pump is supplied with a blocked compressor. "Permitted" means that the compressor is allowed to start.

Stop at outdoor °C **-22 (-22...10)**

This menu relates to settings for the outdoor temperature at which the compressor is no longer permitted to operate. The heat pump starts 2°C above the set value.

Only applies to air-to-water heat pumps.

Charge pump % **50% (20...100)**

The speed of the charge pump is set here.

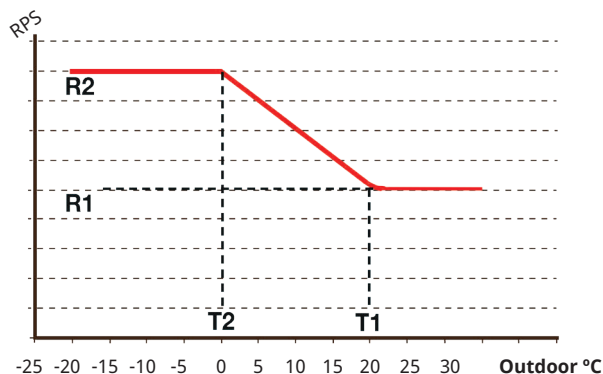

The diagram shows that the compressor speed is controlled according to the outside temperature.

When the outside temperature is below T2, the compressor speed adjusts up to R2.

When the outside temperature exceeds T1, the compressor speed adjusts down to R1.

These temperature and speed limits are set in the menus on the left.

Cold temp limit **0 (0...-15)**

Temperature limit for "winter power".

When the outdoor temperature is equal or lower (T2), the compressor speed is adjusted up to speed R2.

Only applies to modulating air-to-water heat pumps.

Max RPS **90* (50...120)**

The maximum permissible speed of the compressor at "winter temperature". Sets the compressor's maximum speed (R2) at outdoor temperature T2.

Only applies to modulating air-to-water heat pumps.

Warm temp limit **20 (0...20)**

Temperature limit for "summer power". When the outdoor temperature is equal or higher (T1), the compressor speed is adjusted down to speed R1. The heat pump starts and stops at the actual value and setpoint value.

Only applies to modulating air-to-water heat pumps.

Max RPS warm temp **50 (50...120)**

The maximum permissible speed of the compressor at "summer temperature". Sets the compressor's maximum speed (R1) at outdoor temperature T1.

Only applies to modulating air-to-water heat pumps.

Ext. noise reduction RPS **50 (20...120)**

Set the compressor speed value applicable for remote control.

Read more in the "Def. Remote Control" section of the "Advanced/Define" chapter.

Schedule, Noise reduction

This menu starts a schedule with limited compressor speed to reduce the noise level.

For more information, see the chapter "Schedule".

Compressor stop at brine °C **-5 (-15...10)**

Specify the brine temperature at which the compressor should stop.

Only applies to liquid-to-water heat pumps.

Brine pump **Auto (Auto/10 days/On)**

After installation is complete, you can choose to run the brine pump constantly for 10 days to remove air from the system. The brine pump then enters "Auto" mode. "On" means the brine pump runs constantly.

Only applies to liquid-to-water heat pumps.

Tariff HP **No (No/Yes)**

"Yes" means the function can be activated via remote control.

Read more in the "Def. Remote Control" section of the "Advanced/Define" chapter.

*The value may vary depending on the heat pump model.

**The number of possible heating circuits or heat pumps that can be connected to the system varies depending on the control system.

Schedule, Tariff HP

This menu bar is displayed if a schedule has been defined for the "Tariff HP" function.

For more information, see the:

- chapter "Schedule".
- section "Def. Remote Control" of the "Advanced/Define" chapter for defining the remote control function.

Passive cooling brine pump On Yes (Yes/No)

Enable "Yes" if the brine pump should be used for passive cooling.

Only applies to liquid-to-water heat pumps.

Schedule, Silent mode

It is possible to start a schedule, e.g. during the night, with limited compressor speed and fan speed to reduce the noise level.

For more information, see the chapter "Schedule".

Only applies to CTC EcoAir 600M/700M/C100.

Max. main current A 16***

Setting the maximum allowed main current for the heat pump.

Only applies to CTC EcoAir 700M/C100.

***Factory setting:	EA712M/EA708M, 1x230V:	16A
	EA712M/EA708M, 3x400V:	13A
	EA720M, 3x400V:	20A
	EA C106, 1x230V:	10A
	EA C108, 1x230V:	12,5A
	EA C108, 3x400V:	5A
	EA C112, 1x230V:	16A
	EA C112, 3x400V:	6A
	EA C116, 1x230V:	22A
	EA C116, 3x400V:	9A

HP relay failsafe 0 (0...7)

Setting the fail-safe mode (bit 0-7). Currently, bit 0 and bit 1 are implemented as follows:

- bit 1: The relay closes (signal on output "External out 1/C7" on the heat pump circuit board) in case of communication failure between the display and the heat pump.
- bit 0: The relay does not close in case of communication failure between the display and the heat pump.

Only applies to CTC EcoAir 700M.

Function HP relay - (Alarm HP/All alarms/Compr. on)

The following settings are possible:

- **Alarm HP:** The relay closes (signal on output "External out 1/C7" on the heat pump control board) in case of an alarm on the heat pump.
- **All alarms:** the relay closes for all alarms on the system.
- **Compr. on:** the relay closes when the compressor is running.

Only applies to CTC EcoAir 700M.

Factory setting: no value is set.

8.2.4 Settings, Additional heat

Set. Additional heat	
Add. heat E1	On
Start add. heat E1, degree min.	-500
Diff E1, degree minutes	-100
Delay add. heat E1	180
Add. heat E2	7
Start E2, degree minutes	-500
Diff E2, degree minutes	-100
Delay add. heat E2	180
Diff delay E2	60
Add. heat EcoMiniEI	No
Start EcoMiniEI, degree minutes	-500
Diff step EcoMiniEI	-50
Delay EcoMiniEI	180
Delay EcoMiniEI step	30
Block additional heat, out °C	5
Boiler, open mix.valve °C	70
Boiler max °C	Off
Main fuse A	20
Conv. factor curr. sensors	1
Tariff EL	No
Schedule, Tariff EL	
SmartGrid Block. immersion	No
Start at flue gas °C	Off
E1 Charge pump HP1 (G11) %	100
E2 Charge pump HP1 (G11) %	70
E3 Charge pump HP1 (G11) %	70

Menu: "Advanced/Settings/Additional Heat".

Additional heat E1 On (Off/On)

Selection "Off" switches off additional heat E1.

Start E1, degree minute -500 (-900...-30)

This menu is used to define at how many degree minutes additional heat E1 should start to operate.

Applies to System Types 1, 2 and 3.

Diff E1, degree minute -100 (-300...-20)

This menu is used to define the difference in degree minutes between the start and stop conditions for additional heat E1. If additional heat is set to start at -500 degree minutes, it will be stopped at -400 degree minutes (based on a difference setting of -100).

Applies to System Types 1, 2 and 3.

Delay add. heat E1 180 (0...480)

This menu is used to state the delay in minutes of subnormal temperature in the buffer tank required before additional heat E1 is started.

Applies to System Types 4-6.

Additional heat E2* 7 (Off/1...3/1...7/1...10)

If a value has been selected, the additional heat is active during heat charging. If "Off" is selected, the additional heat is blocked.

Start E2, degree minute** -500 (-900...-30)

This menu is used to define at how many degree minutes the immersion heater should start.

Applies to System Types 2 and 3.

Diff E2, degree minute** -100 (-300...-20)

This menu is used to define the difference in degree minutes between the start and stop conditions for the immersion heater. If the immersion heater is started at -500 degree minutes, it will be stopped at -400 degree minutes (for a setting of -100).

Applies to System Types 2 and 3.

Delay add. heat E2 180 (30...480)

This menu is used to state the delay in minutes of subnormal temperature in the buffer tank required before immersion heater (E2) is started.

Applies to System Types 4-6.

Diff delay E2 60 (10...120)

This menu is used to define the difference in minutes between the start and full power conditions for the immersion heater. If, for example, the immersion heater is started after 180 minutes of subnormal temperature, full power will be achieved after 240 minutes (for a setting of 60).

Applies to System Types 4-6.

Additional heat EcoMiniEI No (No/1/2/3)

This menu bar is displayed if CTC EcoMiniEI is defined. Specify whether the immersion heater should connect in 1, 2 or 3 steps.

Applies to System Types 2, 3 and 4.

Start EcoMiniEI, degree minute -500 (-900...-30)

This menu is used to define at how many degree minutes CTC EcoMiniEI will start.

Applies to System Types 2 and 3.

Diff step EcoMiniEI -50 (-300...-20)

This menu is used to define the difference in degree minutes between the start and stop conditions for CTC EcoMiniEI. If the electric boiler is started at -500 degree minutes, it will be stopped at -450 degree minutes (for a setting of -50).

Applies to System Types 2 and 3.

**The value that can be selected (1-3 steps/1-7 steps/1-10V) depends on how the additional heat has been defined on the line "Add. heat (E2)" in the menu "Advanced/Define/System type".*

***Applies to CTC EcoLogic XL/L.*

Delay EcoMiniEI 180 (30...480)

This menu is used to specify the number of minutes of subnormal temperature in the buffer tank after which CTC EcoMiniEI is required to start.

Applies to System Type 4 if steps (1, 2, 3) are selected in the "Additional heat EcoMiniEI" menu.

Delay EcoMiniEI step 30 (10...120)

This menu is used to specify the delay (between steps) with which CTC EcoMiniEI is required to start.

Applies to System Type 4 if steps (1, 2, 3) are selected in the "Additional heat EcoMiniEI" menu.

Block add. heat, outdoor °C 5 (-40...40)

This menu is used to set the outdoor temperature at which additional heat should be blocked.

Boiler, open mix.valve °C 70 (10...80)

This menu is used to define the temperature at which the additional heat mixing valve should open.

Boiler max °C Off (30...120)

Operating thermostat for additional heat (E1) in Additional Heat mode.

When the set temperature is reached, the output (E1/A11) on the relay board is switched off. "Off" means that relay output E1/A11 is switched on in Additional Heat mode.

Main fuse A 20 (10...90)

The size of the house's main fuse is set here. This setting and the fitted current sensors ensure the fuses are protected when using appliances which generate temporary power peaks, for example, cookers, ovens, engine heaters, etc. The product temporarily reduces power drawn where this type of equipment is being used.

Conv. factor curr. sensors 1 (1...10)

This menu is used to specify the factor to be used by the current sensor. This setting is only performed if the connection has been installed for a current sensor for higher currents.

Example: User (set) value 2 => 16 A will be 32 A.

Tariff EL No (Yes/No)

This menu bar is displayed if an "Input" for remote control is defined for the "Tariff EL" function in the "Advanced/Define/Remote Control" menu.

"Yes" means the function can be activated via remote control.

Read more in the "Remote Control/Tariff EL" section of the "Advanced/Define" chapter.

Schedule, Tariff EL

This menu bar is displayed if a schedule has been defined for the "Tariff EL" function.

For more information, refer to:

- chapter "Schedule".
- section "Def. Remote Control" of the "Advanced/Define" chapter for defining the remote control function.

SmartGrid Block. immersion No (Yes/No)

For this menu to be displayed, define a remote control input for both SmartGrid A and SmartGrid B.

"Yes" means that the additional heat is blocked when "SmartGrid Blocking" is active.

Read more in the "Def. Remote Control" section of the "Advanced/Define/" chapter.

Start at flue gas °C Off (Off/50...250)

This menu is used to define the flue gas temperature (sensor B8) at which the system will enter wood operation status and the heat pump(s) stops.

Wood operation is activated when the flue gas temperature exceeds the set value in this menu and the temperature is equal to or above its reference value (setpoint). When wood operation is active, the heat pump or additional heat is not used for heating. Wood operation is deactivated when the flue gas temperature drops below the set value in this menu. Wood operation can also be activated when the primary flow sensor (B1) is 10 °C above the setpoint.

Applies to System Type 1.

E1 Charge pump HP1 (G11) % 100 (0...100)

Speed of charge pump 1 (G11) when additional heat E1 is active and has been defined.

Applies to System Type 4.

E2 charge pump HP1 (G11) % 70 (0...100)

Charge pump 1 (G11) achieves at least this speed when the immersion heater E2 is active.

E3 charge pump HP1 (G11) % 70 (0...100)

Charge pump 1 (G11) achieves at least this speed when additional heat E3 is active and has been defined.

Applies to System Types 2 and 4.

8.2.5 Settings, DHW tank

The menus below are displayed if "DHW tank" has been defined in the "Advanced/Define /DHW tank" menu. The temperature in the DHW tank is measured using either one sensor (B5) or two sensors (B5 and B79).

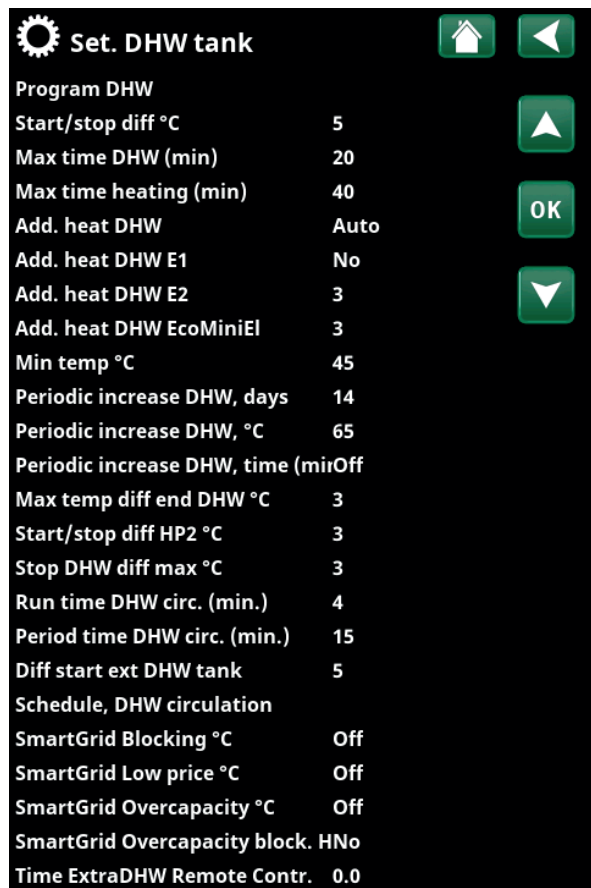

Menu: "Advanced/Settings/DHW Tank".

Program DHW

Available options are "Economy", "Normal" and "Comfort".

Press "OK" to open the settings for the selected DHW program. The factory settings shown below apply to "Normal" mode. Refer to the "Parameter List" chapter for the "Economy" and "Comfort" modes' factory settings.

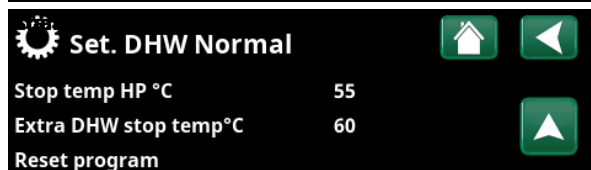
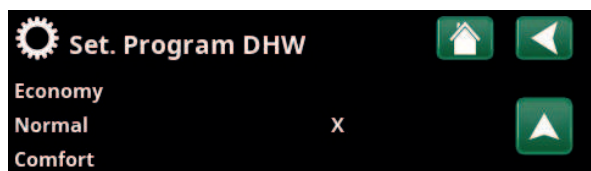

Menu: "Advanced/Settings/DHW Tank/DHW Program".

• Stop temp HP °C 55 (20...60)

At the selected temperature, the heat pump stops charging the DHW tank.

• Extra DHW stop temp °C 60 (20...62/70*)

This menu is used to specify the setpoint for the heat pump to charge DHW.

• Reset program

The current DHW program will be restored to factory settings.

Start/Stop diff °C 5 (3...7)

This menu is used to set the negative hysteresis before the heat pump starts charging the DHW tank after the setpoint has been reached.

Example: If the stop temperature is 55 °C and hysteresis is set to 5 °C in this menu, it means the heat pump will start DHW charging again when the temperature in the tank has dropped to 50 °C.

Max time DHW (min) 20 (5...60)

This specifies the maximum time for which the heat pump heats the DHW tank.

Max time heating (min) 40 (5...60)

This is the maximum time for which the heat pump heats the heating circuit, if DHW charging is required.

Additional heat DHW Auto (Yes/No/Auto)

This menu is used to define whether additional heat needs to be active in parallel with the heat pump charging the DHW tank.

"Yes" means the setpoint for additional heat is automatically set to equal the heat pump setpoint for the DHW tank.

"Auto" means that additional heat works according to the value set for DHW tank additional heat. "No" means additional heat should not be active during DHW charging.

Additional heat DHW E1 No (Yes/No)

If "Yes" is selected, additional heat is active during DHW charging. If "No" is selected, the additional heat is blocked.

Additional heat DHW E2 3** (Off/1...3/1...7/1...10)

If a value has been selected, the additional heat is active during hot water charging. At "Off" it is blocked.

Add. heat DHW EcoMiniEI 3 (Off/1...3)

If "Step 1-3" is selected, additional heat is active during DHW charging. If "Off" is selected, the additional heat is blocked.

Min temp °C 45 (20...55)

This menu is used to specify the lowest permitted temperature in the DHW tank.

Periodic increase DHW, days 14 (Off/1...30)

The menu defines the interval of the periodic increase of the hot water for legionella protection.

1 = Every day, 2 = Every other day, 3 = Every third day, etc...

Periodic increase DHW, °C 65 (57...65)

Set the temperature for the periodic increase.

*The value may vary depending on the heat pump model.

**Depends on whether E2 has been defined 0-10V or in steps (0-1, 0-3 alt. 0-7).

Periodic increase DHW, time (min) Off (Off/1...60)

Set the number of minutes for how long the set temperature will be exceeded.

Max temp diff end DHW °C 3 (2...7)

If there is a heating requirement, DHW charging is interrupted before maximum temperature is reached, in order to avoid the compressor stopping while switching DHW to heating.

Start/Stop diff (2 options)

Start/Stop diff HP2 °C (One sensor B5)* 3 (0...10)**

DHW charging using valve Y22 takes place if the DHW temperature is below the start value by the set difference.

Start/Stop diff °C (Two sensors B5 and B79)* 3 (0...10)**

HP2 stops when the DHW temperature exceeds the set difference.

Stop DHW diff max °C 3 (2...10)

DHW charging is normally interrupted in the DHW sensor, but this can also occur in the condensation temperature which is calculated based on the heat pump's internal pressure sensor. The condensation temperature is significantly increased during DHW charging. This menu relates to the value from the maximum permitted condensation temperature that interrupts DHW charging. If there is a heating requirement, the system then diverts to charging the heating circuit.

Run time DHW circ. (min) 4 (1 to 90)

The length of time that DHW circulation should active during each period. Displayed if "DHW circulation" has been defined in the "Advanced/Define/DHW tank" menu.

Period time DHW-circ. (min) 15 (5...90)

Time between periods of DHW circulation. Displayed if "DHW circulation" has been defined in the "Advanced/Define/DHW tank" menu.

Diff start ext. DHW tank** 5 (3...15)**

This menu bar is displayed if "External DHW Tank" has been defined in the "Advanced/Define/DHW Tank" menu. This menu is used to select the temperature difference at which the charging of the external DHW tank is required to start. The difference is specified in relation to the setpoint that is set in the "DHW Program/Stop temp HP °C" menu.

Schedule, DHW circulation

This menu displays scheduled periods during the week when the circulation pump for DHW circulation should run.

The menu bar is displayed if:

- "DHW circulation" has been defined in the "Advanced/Define/DHW tank" menu.
- a "Schedule" is defined for the DHW Circulation" function in the "Advanced/Define/Remote Control" menu.

For more information, refer to:

- chapter "Schedule".
- section "Def. Remote Control" of the "Advanced/Define" chapter for defining the remote control function.



Menu: "Advanced/Settings/DHW Tank/Schedule, DHW circulation". In the example above, "DHW circulation" is activated every week - Monday to Friday between 06:30 and 07:00.

SmartGrid Blocking °C Off (Off/-1...-50)

The setpoint for DHW tank heating is decreased by the value set in this menu when "SmartGrid Blocking" is active.

Both SmartGrid A and SmartGrid B must be defined in the remote control menu for this menu to be displayed.

Read more in the "Def. Remote Control /SmartGrid A/B" section of the "Advanced/Define" chapter.

SmartGrid Low price °C Off (Off/1...30)

The setpoint for DHW tank heating is increased by the value set in this menu when "SmartGrid Low price" is active.

Both SmartGrid A and SmartGrid B must be defined in the remote control menu for this menu to be displayed.

Read more in the "Def. Remote Control /SmartGrid A/B" section of the "Advanced/Define" chapter.

SmartGrid Overcapacity °C Off (Off/1...30)

The setpoint for DHW tank heating is increased by the value set in this menu when "SmartGrid Overcapacity" is active.

Both SmartGrid A and SmartGrid B must be defined with a remote control input for this menu to be displayed.

Read more in the "Def. Remote Control /SmartGrid A/B" section of the "Advanced/Define" chapter.

SmartGrid Overcapacity block HP No (No/Yes)

"Yes" means that DHW tank heating using the heat pump is blocked when "SmartGrid Overcapacity" is active.

Time ExtraDHW Remote Control 0.0 (0.0...10.0)

Set the time (hours) that the production of additional hot water to the DHW tank should continue. The 'Extra DHW' function is activated via the remote control.

The menu bar is displayed if:

- a normal mode for the external control signal (Normally Open (NO)/Normally Closed (NC)) is defined for the function in the "Advanced/Define/DHW Tank" menu.
- an "Input" for "Extra DHW" has been defined in the "Advanced/Define/DHW tank" menu.

***This menu only applies to systems that have a diverting valve Y22 defined.

****Only applies to CTC EcoLogic L.

8.2.6 Settings, Buffer tank

The menu applies only to systems with a buffer tank (System Types 4-6) if "Buffer Tank" has been defined (menu: "Advanced/Define /Buffer Tank". The temperature in the buffer tank is measured using either one sensor (B6) or two sensors (B6 and B80).

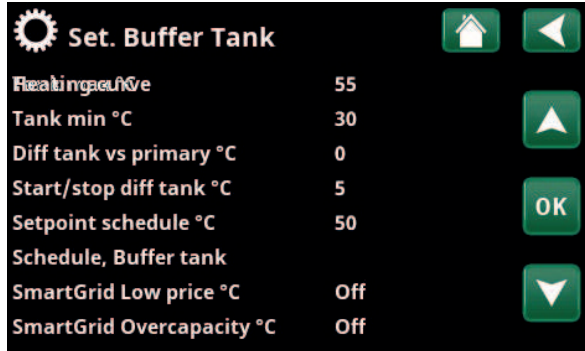

Menu: "Advanced/Settings/Buffer tank".

Heating curve

The menu bar is displayed if no heating system is defined in the "Advanced/Define/Heating circuit" menu.

See the description of "Heating curve Buffer tank" in this chapter.

Tank max °C **55 (20...90)**

Setting for preferred maximum temperature in the buffer tank.

Tank min °C **30 (5...60)**

Setting for preferred minimum temperature in the buffer tank.

Diff tank vs primary °C **0 (0...15)**

This menu is used to set the preferred difference between the temperature in the tank and the outgoing primary flow temperature to the heating circuit.

Start/Stop diff tank °C **5 (3...10)**

This menu is used to set the negative hysteresis before the heat pump starts charging the buffer tank after the setpoint has been reached.

Example: If the stop temperature is 55 °C and hysteresis is set to 5 °C in this menu, it means the heat pump will start charging again when the temperature in the tank has dropped to 50 °C.

Setpoint schedule °C **50 (20...60)**

This menu is used to set the setpoint to which the buffer tank works during external activation (remote control) and when programming a heating schedule.

For more information, refer to:

- chapter "Schedule".
- section "Def. Remote Control" of the "Advanced/Define" chapter for defining the remote control function.

Schedule, Buffer tank

This menu bar is displayed if a schedule has been defined in the "Buffer Tank" row in the "Advanced/Define/Remote Control" menu.

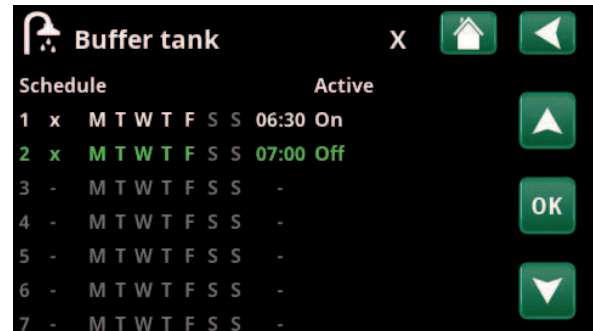

In the example, buffer tank heating is activated every week - Monday to Friday between 06:30 and 07:00.

For more information, refer to:

- chapter "Schedule".
- section "Def. Remote Control" of the "Advanced/Define" chapter for defining the remote control function.

SmartGrid Low Price °C **Off (Off/1...30)**

The setpoint increase for heating the buffer tank when "SmartGrid Low Price" is active can be set here.

Read more in the "Advanced/Define/Remote control/SmartGrid" menu.

SmartGrid Overcapacity °C **Off (Off/1...30)**

The setpoint increase for heating the buffer tank when "SmartGrid Overcapacity" is active can be set here.

Read more in the "Advanced/Define/Remote control/SmartGrid" menu.

Allow overtemp during cooling* **No (Yes/No)**

Selection "No" means that the buffer tank only charges up to the setpoint.

Selection "Yes" means that the buffer tank charges warmer than the setpoint.

*This menu bar is only displayed if active cooling has been defined in the "Advanced/Define/Cooling" menu.

Heating curve, Buffer tank

The heating curve determines the setpoint for the buffer tank at different outdoor temperatures.

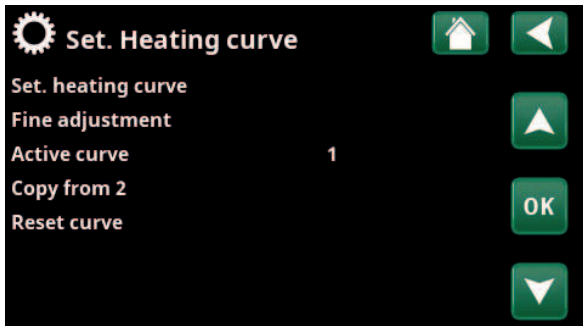

Menu "Advanced/Settings/Buffer tank/Heating curve".

• Set. heating curve

The thicker line shows the factory-set curve while the thinner line shows the active heating curve to be reset.

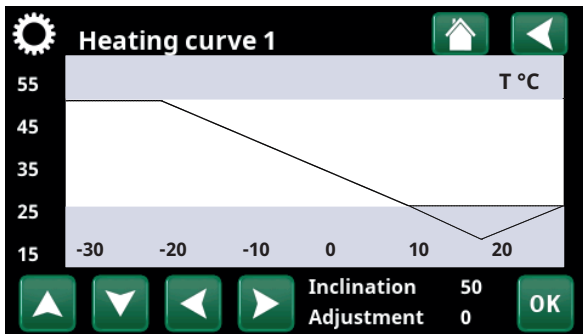

Menu "Advanced/Settings/Buffer tank/Heating curve/ Set. heating curve".

Here it is possible to adjust the appearance of the graph by adjusting the curve inclination and curve adjustment with the buttons below the graph. The adjustments you make here affect the entire appearance of the graph, while the changes made under "Fine adjustment" are made one point at a time. Curve inclination is adjusted with the left and right arrows while curve adjustment is adjusted with the up and down arrows. Confirm with "OK".

• Fine adjustment

The graph of the active heating curve for the buffer tank is displayed.

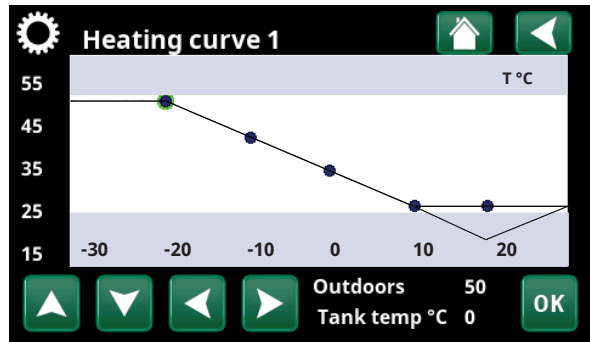

Menu "Advanced/Settings/Heating Circuit/Heating Circuit 1/Heating curve/Fine adjustment".

The heating curve can be adjusted in 5 points on the graph. Touch a point (becomes green) to change its position in the x-axis (outdoor temperature) and y-axis (primary flow temperature). Use the up/down/left/right buttons below the graph or press and drag the point. Below the graph, the outdoor and primary flow temperatures for the selected point are shown. The heating curve can also be adjusted from the "Heating/Cooling" menu, see chapter "Display settings".

• Active curve 1 (1/2)

This menu bar shows the selected heating curve, it is possible to choose between two different heating curves for the buffer tank.

• Copy from 1 (2)

The function "Copy from" is useful if you have created two different heating curve graphs but want to restore one graph to the same appearance as the other and then make changes.

Example: If heating curve 1 is selected as "Active curve", heating curve 1 will have the same appearance as heating curve 2 by selecting the line "Copy from 2" and pressing "OK". The menu bar cannot be selected (marked with gray) when heating curves 1 and 2 have the same values (the graphs look the same).

• Reset curve

Resets the active heating curve to the factory-set curve.

8.2.7 Settings, Solar collectors*

Set. Solar collectors	
dT max solar °C	7
dT min solar °C	3
Min speed pump %	30
Max boiler °C	85
Max DHW tank °C	85
Max buffer tank °C	85
Max temp brine °C	18
dT max bedrock °C	60
dT min bedrock °C	30
Solar test tank (min)	4
Test frequency min	30
Winter mode	No
Flow l/min	6.0
Protection collector	

Menu: "Advanced/Settings/Solar collectors".

dT max solar °C **7 (3...30)**

When the temperature difference between the solar collectors and the DHW tank exceeds the set value, the charge pump on the solar collectors (G30) should begin producing DHW for the DHW tank.

dT min solar °C **3 (2...20)**

When the temperature difference between the solar collectors and the DHW tank reaches the set value, the charge pump on the solar collectors (G30) should stop.

Min speed pump % **30 (30...100)**

The minimum permitted speed (rpm) for the circulation pump (G30) is set here.

Max boiler °C **85 (10...95)**

The maximum permitted temperature in the boiler. Charging of the boiler ceases once the set temperature has been reached.

Applies to System Type 1.

Max DHW tank °C **85 (10...95)**

The maximum permitted temperature in the DHW tank. Charging stops once the set temperature has been reached.

Max buffer tank °C **85 (10...95)**

The maximum temperature in the buffer tank. Charging stops once the set temperature has been reached.

Max temp brine °C **18 (1...50)**

Setting for maximum permitted brine temperature. Solar charging of the borehole ceases when this value has been reached.

NB! This should not be adjusted without consulting your installer.

dT max borehole °C **60 (3...120)**

Setting for start conditions for solar charging of borehole. Specifies the temperature difference (solar collectors-borehole) at which charging begins.

dT min borehole °C **30 (1...118)**

Setting for stop conditions for solar charging of borehole. Specifies the temperature difference (solar collectors-borehole) at which charging stops.

Solar test tank (min) **4 (1...20)**

(Used only if evacuated tube solar collectors have been defined.) When recharging the borehole, switching to tank charging is done once every 30 minutes to check whether tank charging is possible. The test is carried out at the set time interval. If enough temperature is obtained, tank charging continues; otherwise the system switches to charging the borehole again.

Test frequency (min) **30 (0...180)**

Specifies the frequency at which the Solar Test function should perform. With 0 as the set value, solar test takes place continuously.

Winter mode **Off (Off/On)**

Deactivate the "Solar test tank (min)" function. "Off" means only borehole charging.

Flow l/min **6.0 (0.1...50.0)**

The flow circulating through the solar collectors should be indicated here. (This can be read from the flow meter in the system unit.) The flow should be read when pump G30 is running at 100%.

NB: It is important the value is correct, as the flow is used as the basis for calculating the power and cumulative energy. Incorrect flows will therefore produce incorrect values for these parameters.

Protection collector

See the "Settings, Protection Collector" chapter below.

*Applies to CTC EcoLogic XL/L.

8.2.7.1 Settings, Protection collector*

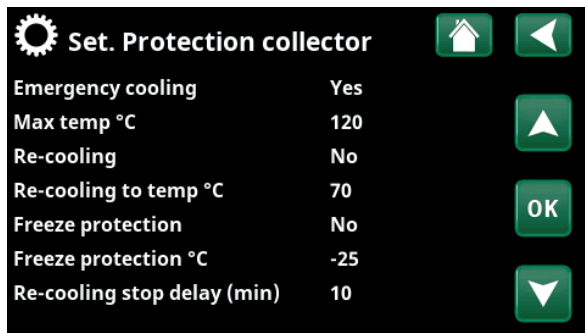

Menu: "Advanced/Settings/Solar collectors/Protection Collector".

Emergency cooling **Yes (Yes/No)**

Allows circulation to the DHW and buffer tank as well as the borehole. This is in order to prevent excessively high temperatures in the solar collectors. Applies once the maximum permitted temperature has been reached.

NB: Under no circumstances are the temperatures in the tanks allowed to exceed 95 °C.

Max temp °C **120 (110...150)**

Protects the solar collectors from high temperatures by allowing circulation in the solar collectors even though the maximum temperature has been reached in the respective tank. For safety reasons, the temperature in the buffer tank is never allowed to exceed 95 °C.

Re-cooling **No (Yes/No)**

This option can be activated when the emergency cooling function has been activated. The function means that the system endeavours reduce the temperature in the DHW and buffer tank to the set setpoint (set in the Re-cooling to temp menu). This means that the solar collectors are used as cooling elements for a short period of time.

Re-cooling to temp °C **70 (50...80)**

This option can be activated when the "Recooling" function has been activated. The function means that the system endeavours reduce the temperature in the DHW tank and buffer tank to the set setpoint.

Freeze protection **No (Yes/No)**

As there is a risk of blocks of ice forming in the solar collectors, circulation may be started to reduce the risk of frost damage.

Freeze protection °C **-25 (-30...-7)**

Specifies the temperature at which frost protection should be activated.

The menu bar is displayed when the "Freeze protection" function has been activated.

Re-cooling stop delay (min) **10 (0...180)**

Delay refers to the time (minutes) before the need for re-cooling (DHW tank and buffer tank) ceases.

*Applies to CTC EcoLogic XL/L.

8.2.8 Settings, Pool*

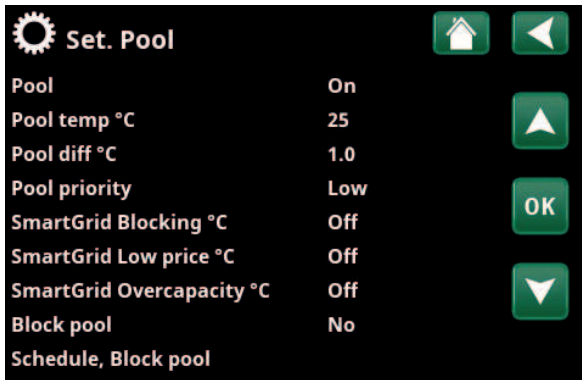

Menu: "Advanced/Settings/Pool".

Pool **On (On/Blocked)**

Whether the pool heating should be "On" or "Blocked" is selected here.

Pool temp °C **22 (20...58)**

The desired pool temperature is set on this menu bar.

Pool diff °C **1.0 (0.2...5.0)**

The permitted difference between the stop and start temperature in the pool is specified here.

Pool priority **Low (Low/High)**

The priority between pool heating and the heating circuit is specified here. If the "Low" setting is selected, the pool is not charged when additional heating is being used.

SmartGrid Blocking °C **Off (Off/-1...-50)**

The setpoint for pool heating is decreased by the value set in this menu when "SmartGrid Blocking" is active.

SmartGrid Low price °C **Off (Off/1...5)**

The setpoint for pool heating is increased by the value set in this menu at "Low price" energy price (when "SmartGrid Low price" is active).

Read more in the "Advanced/Define/Remote control/SmartGrid" menu.

SmartGrid Overcapacity °C **Off (Off/1...5)**

The setpoint for pool heating is increased by the value set in this menu at "Overcapacity" energy price (when "SmartGrid Overcapacity" is active).

Read more in the "Advanced/Define/Remote control/SmartGrid" menu.

Block pool **No (Yes/No)**

This function is used to block external pool heating. This menu bar is displayed if the criteria below are met:

- the pool is connected (defined) to the system
- a remote control input has been defined for the "Block pool" function.
- a normal mode (Normally Open (NO) or Normally Closed (NC)) for the external control signal has been defined.

Read more in the "Def. Remote Control" section of the "Advanced/Define" chapter.

Schedule, Block pool

This menu is used to schedule the days of the week when pool heating should be blocked. This schedule is repeated every week. This menu bar is displayed if a schedule has been defined for the "Block Pool" function.

For more information, refer to:

- chapter "Schedule".
- section "Def. Remote Control" of the "Advanced/Define" chapter for defining the remote control function.

*Applies to CTC EcoLogic XL/L.

Tank min °C 5 (5...50)

This menu specifies the minimum permissible temperature in the tank when cooling demand is active.

Heat exchanger diff. °C 10 (0...15)

The permitted temperature difference on either side of the heat exchanger is specified here.

SmartGrid Low price °C Off (Off/1...5)

The setpoint for room temperature is decreased by the value set in this menu when "SmartGrid Low price" is active.

The menu bar is displayed if SmartGrid have been defined in the "Advanced/Define/Remote Control" menu.

Read more in the "Remote Control/SmartGrid" section of the "Advanced/Define" chapter.

SmartGrid Overcapacity °C Off (Off/1...5)

The setpoint for room temperature is decreased by the value set in this menu when "SmartGrid Overcapacity" is active.

The menu bar is displayed if SmartGrid have been defined in the "Advanced/Define/Remote Control" menu.

Read more in the "Remote Control/SmartGrid" section of the "Advanced/Define" chapter.

Ext. block cooling No (Yes/No)

Blocking cooling can be remote controlled remotely. For example, the function can be used to turn off cooling with the help of a humidity sensor when there is a risk of condensation.

This menu bar is displayed if the criteria below are met:

- a remote control input has been defined for the "Block cooling" function.
- a normal mode (Normally Open (NO) or Normally Closed (NC)) for the external control signal has been defined on the menu bar "Block cooling ext. config." in the "Advanced/Define/Cooling" menu.

Read more in the "Def. Remote Control" section of the "Advanced/Define" chapter.

Schedule, Blocking cooling

This menu is used to schedule the weekday periods during which cooling should be blocked. This schedule is repeated every week.

This menu bar is displayed if a schedule has been defined for the "Block Cooling" function, in the "Advanced/Define/Remote Control" menu.

For more information, refer to:

- chapter "Schedule".
- section "Def. Remote Control" of the "Advanced/Define" chapter for defining the remote control function.

Max temp brine °C 18 (1...30)

The highest permitted brine temperature.

Start HP delay 30 (Från/1...180)

The time (min) that passive cooling has to lower the temperature in the cooling tank to the cooling demand.

If the temperature in the cooling tank is lowered, the delay time is reset. In other words, if the temperature in the cooling tank drops before the time interval has expired, the delay time is reset to the set value again.

When the delay time has expired, the heat pump starts if the cooling demand has not been met.

If a heating demand occurs, cooling to the cooling tank is automatically interrupted.

Passive cooling must be defined in "Advanced/Define/Cooling/Passive cooling" for this menu to be displayed.

Cooling curve

The cooling curve determines the primary flow temperature (and thus the indoor temperature) to the heating circuit at different outdoor temperatures.

Possible choices are "Set. cooling curve", "Fine adjustment", "Active curve", "Copy from ..." and "Reset curve".

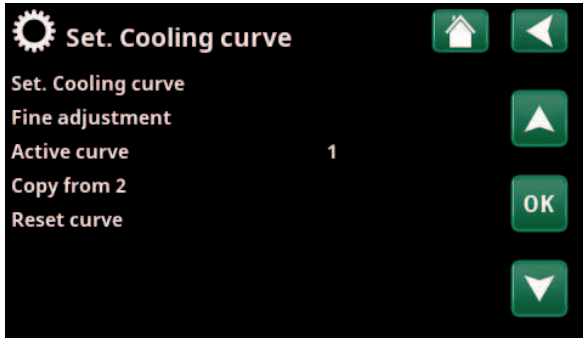

Menu "Advanced/Settings/Cooling/Cooling curve/Set. Cooling curve".

• Settings, Cooling curve

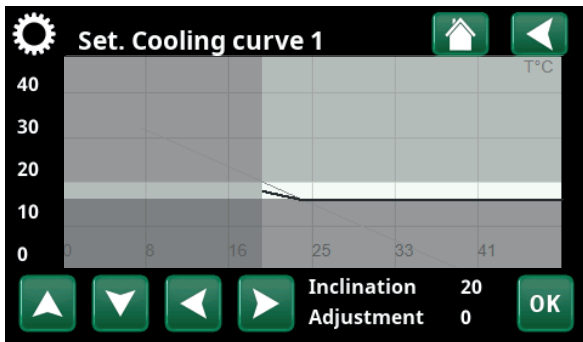

Menu "Advanced/Settings/Cooling/Cooling curve/Set. Cooling curve".

Here it is possible to adjust the appearance of the graph by adjusting the curve inclination and curve adjustment with the buttons below the graph. The adjustments you make here affect the entire appearance of the graph, while the changes made under "Fine adjustment" are made one point at a time. Curve inclination is adjusted with the left and right arrows while curve adjustment is adjusted with the up and down arrows. Confirm with "OK".

• Fine adjustment

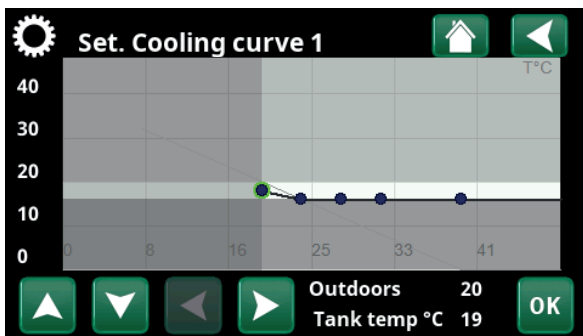

Menu "Advanced/Settings/Cooling/Cooling curve/Fine adjustment".

change its position in the x-axis (outdoor temperature) and y-axis (primary flow temperature). Use the up/down/left/right buttons below the graph or press and drag the point.

Below the graph, the outdoor and primary flow temperatures for the selected point are shown.

The cooling curve can also be adjusted from the "Heating/Cooling" menu, see chapter "Display settings".

• Active curve 1 (1/2)

This menu bar shows the selected cooling curve, it is possible to choose between two different cooling curves per heating circuit.

• Copy from 1 (2)

The function "Copy from ..." is useful if you have created two different cooling curve graphs but want to restore one graph to the same appearance as the other and then make changes.

Example: If cooling curve 1 is selected as "Active curve", cooling curve 1 will have the same appearance as cooling curve 2 by selecting the line "Copy from 2" and pressing "OK". The menu bar cannot be selected (marked with gray) when cooling curves 1 and 2 have the same values (the graphs look the same).

• Reset curve

Resets the active cooling curve to the factory-set curve.

Example Cooling curve

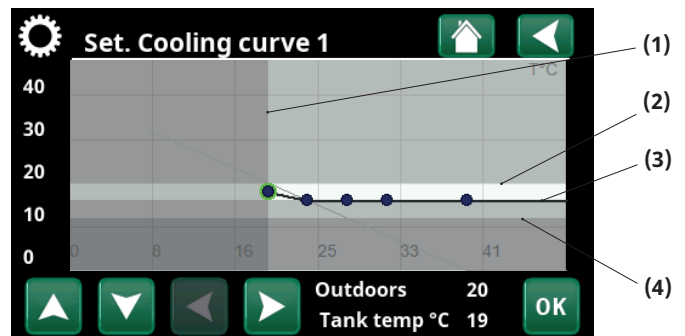

Menu "Advanced/Settings/Cooling/Cooling curve/Fine adjustment".

Menu "Settings Cooling"	Setting "Example Cooling curve"
(1) Cooling permit. from outdoor °C	20
(2) Max primary flow °C	20
(3) Min primary flow °C	18
(4) Min flow temp cooling °C (Coded settings)	16

The specified min. and max. values of the cooling flow define the operating range of the system (the light-colored field between the grey areas in the menu screens "Set. Cooling curve").

The graph of the active cooling curve for the heating circuit is displayed. The cooling curve can be adjusted in 5 points on the graph. Touch a point (becomes green) to

8.2.10 Settings, Communication

Settings can be made here to control the product with a control system.



Menu: "Advanced/Settings/Communication".

8.2.10.1 Settings, Ethernet

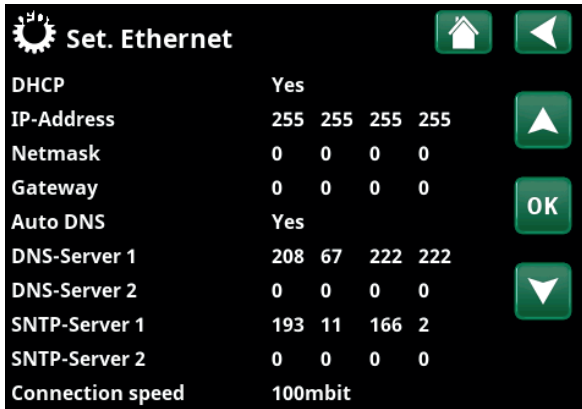

Menu: "Advanced/Settings/Communication/Internet".

DHCP Yes (Yes/No)

"Yes" enables automatic connection to the network.

If "No", custom router settings (IP address, Netmask and Gateway) as well as DNS setting must be made.

Auto DNS Yes (Yes/No)

If "Yes", default DNS server settings are used. If "No", custom DNS settings must be made.

SNTP Server

Option for custom SNTP server settings.

Connection speed 100mbit

Connection speed is specified here.

The factory-set connection speed is 100 mbit/s.

For more information on installing Ethernet cables, see the chapter "Installation, Communication".

8.2.10.2 Settings, BMS

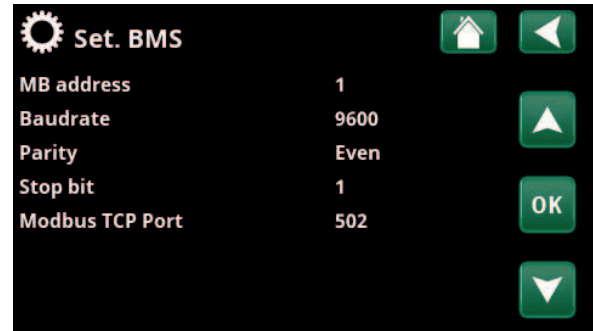

Menu: "Advanced/Settings/Communication/BMS".

MB address 1 (1...255)

Adjustable "1-255".

Baudrate 9600 (9600/19200)

Possible settings: "9600" or "19200".

Parity Even (Even/Odd/None)

Possible settings: "Even", "Odd" or "None".

Stop bit 1 (1/2)

Possible settings: 1 or 2.

Modbus TCP Port 502 (1...32767)

This menu bar is displayed if "Modbus TCP" is defined in the "Ethernet" row in the "Advanced/Define/Remote Control" menu.

8.2.10.3 Settings, myUplink

The menu is used for pairing with the myUplink app.



Menu: "Advanced/Settings/Communication/myUplink".

Request connection string by pressing "Get connection string", confirm with "OK". The menu bar is clickable if the display is connected to the server.

In the app: Scan the QR code or enter values for "Serial" and "Connection string".

Select the menu items "Remove users" and / or "Remove service partners" to disconnect these accounts from the system. Confirm with "OK".

8.2.10.4 Settings, El. prices

Ensure that "myUplink" is selected in the "Def. Communication" menu.

Select "El.prices" in the "Advanced/Settings/Communication" menu to access the "Set. El.prices" menu.



Menu: "Advanced/Settings/Communication/El.prices" where "Advanced/Define/Communication/myUplink: Yes" is selected.

Price control On/Off

Select "On" to show the other menu lines of the "Set. El.prices" display menu.

Regions SE01/SE02/SE03/SE04

Click "OK" on the "Regions" line. If "Regions" are defined for the selected country (see "Advanced/Display/Country" menu), price regions for the country are shown here. Otherwise, the text "No regions available" is displayed. In this example, Swedish price regions are displayed.

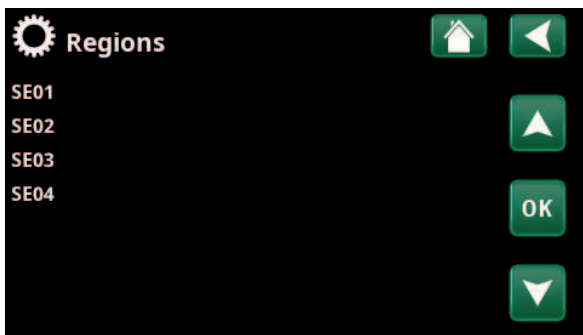

Menu: "Advanced/Settings/Communication/El.prices/Regions" where "Advanced/Define/Communication/myUplink:Yes" is selected

Dynamic Yes/No

"Yes" means that the electricity prices are calculated according to price algorithms that define the price categories ("High", "Medium" and "Low").

Limit value high

Set the limit value above which the electricity price is defined as "High" (in the example, the limit value is SEK 3.50). This can be used together with the dynamic price calculation feature to define a different "High" price range than that determined by the dynamic price calculation feature.

Prices defined as "High" activate the "SmartGrid Blocking" function.

Limit value low

Set the limit value below which the electricity price is defined as "Low" (in the example, the limit value is SEK 1.50). This can be used together with the dynamic price calculation feature to define a different "Low" price range than that determined by the dynamic price calculation feature.

Prices defined as "Low" activate the "SmartGrid Low price" function.

For more information and examples of Smart Electricity Price Control/SmartGrid, see the website www.ctc-heating.com/Products/Download.

Default High/Medium/Low

Select the price category that should apply if prices cannot be retrieved.

Days in calculation 1...10

Select the number of days on which the dynamic calculation of the electricity price will be based. Since the dynamic calculation is based on the average price per day, more days in calculation result in a more stable and reliable value.

Preview data

Click "OK" on the "Preview data" line to display a graph of electricity prices calculated over the selected time interval ("Days in calculation").

The graph can also be displayed by clicking the "El.prices" icon in the "Operation" main menu (see "Operation" section).

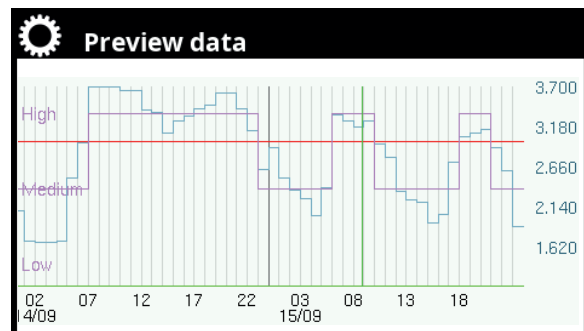

Menu: "Advanced/Settings/Communication/El.prices/Preview data".

Offset % 0 (0...100)

Enter code "4003" in the "Advanced/Service/Coded settings/Code" menu to display the "Offset %" menu line.



Menu: "Advanced/Service/Coded settings/Code".

"Offset" is the boundary between where "High" price and "Medium" price electricity is determined and is based on the average price for the number of days used in the calculation.

If offset is changed, it will move the curve and the shape will be kept. Use "Inclination" to change the curve.

Width % 50 (0...200)

Enter code "4003" in the "Advanced/Service/Coded settings/Code" menu to display the "Width %" menu line.

"Width" is the vertical price range where the electricity price is considered "Medium".

8.2.10.5 Settings, Power limitation

Power limitation can be used, for example, if the if the electricity grid operator requires control of the electricity grid load. The function can limit the operating power of the compressor and the immersion heater.

Press "OK" on the "Power limitation" menu bar in the "Advanced/Define/Communication/Power limitation" menu.

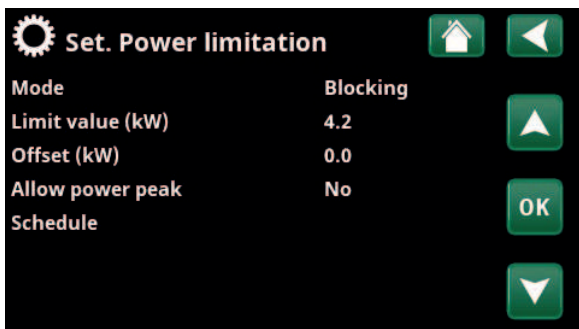

Menu: "Advanced/Settings/Communication/Power limitation".

! CTC EcoLogic L/M and CTC EcoPart i600M must have program version 2025-02-06 or later.

Mode Blocking (Blocking/Limitation/Off)

Select "Blocking" if both the heat pump and the additional heat should be blocked from starting.

Select "Limitation" if the operating power of the heating circuit is to be limited. The limit value and the offset must then be set.

Limit value (kW) 4.2 (1.0...100.0)

Select the operating power value that the heating circuit must not exceed.

Offset (kW) 0.0 (0.0...10.0)

Deduction from the limit value in addition to the operating power of the compressor and the immersion heater.

Allow power peak Yes (Yes/No)

Enter code "4003" in the "Advanced/Service/Coded settings/Code" menu to display the "Allow power peak" menu line.

Select "Yes" if the heat pump is allowed to exceed the set limit value for a short time during start-up. Only applies to modulating heat pumps.

Schedule Off/On/Load fact.set.

In the schedule, the periods is sets for when the power limitation should be active or inactive during the weekdays. For more information, see chapter "Schedule".

8.2.11 Settings, Ventilation

Settings for the CTC EcoVent ventilation product are made here.

For more information, see the "Installation and Maintenance Manual" for CTC EcoVent.

8.2.12 Settings, Current sensor

These menu bars are displayed if "Current Sensor" is defined in the "Advanced/Define/Current Sensor" menu.

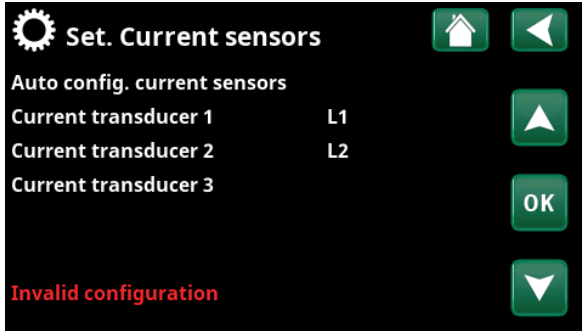

Menu: "Advanced/Settings/Current sensors".

In the menu, specify the phases (L1, L2 and L3) to which the current sensors have been connected.

In the lower left corner of the display, "Invalid configuration" will be displayed until L1, L2, and L3 have been paired with the three current sensors in the menu.

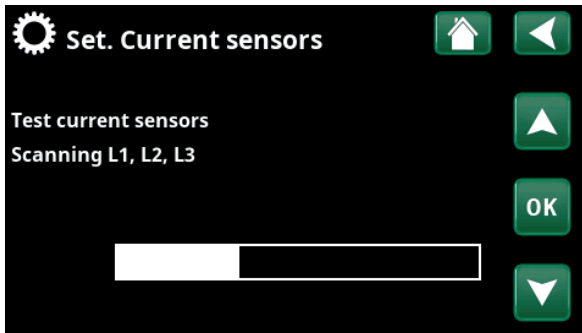

Menu: "Advanced/Settings/Current sensors /Auto config. current sensor".

When activating the "Auto config. current sensors" function, it is important that you have switched off all devices in the house that consume high levels of electricity. Also make sure that the backup thermostat is switched off.

8.2.13 Settings, Round circulation schedule

Round circulation is equipment which an electricity supplier can fit in order to disconnect, for a short period of time, equipment which draws high current. The compressor and electrical output are blocked when round circulation is active.

This menu bar is displayed if a weekly program has been defined for the "Round circulation" function.

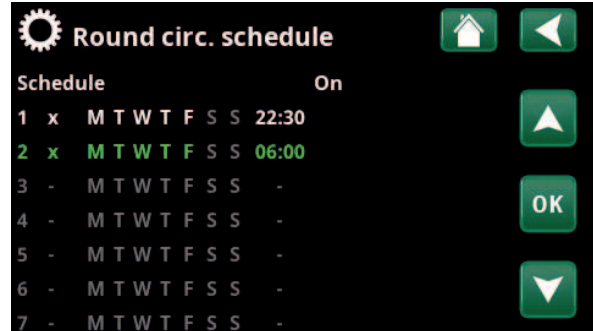

Menu: "Advanced/Settings/Round circulation".

The "Round circulation" function can also be controlled remotely by activating the "Input" defined for the function.

For more information, refer to:

- chapter "Schedule".
- section "Def. Remote Control" of the "Advanced/Define" chapter for defining the remote control function.

8.2.14 Settings, SmartGrid schedule

This menu is used to schedule the weekday periods during which the "SmartGrid" functions should be active. This schedule is repeated every week.

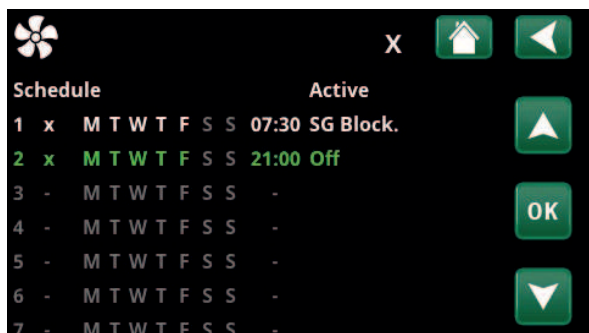

Menu: "Advanced/Settings/SmartGrid schedule".

"SmartGrid" can be used to block a function ("SG Block.") or to achieve a temperature increase during periods when the energy price is low ("SG Low price") or ("SG Overcapacity").

SG Normal mode can be used to easily deviate from any SmartGrid settings for the system on specific days/at specific times.

The "SmartGrid schedule" menu bar is displayed if a schedule has been defined in the "SmartGrid A" row.

For more information, refer to:

- chapter "Schedule".
- chapter "Advanced/Define/Remote Control" for defining SmartGrid.

8.2.15 Save settings

Custom settings can be saved to "Bank" 1-3 and on a USB drive here. The "USB" row is greyed out until the USB drive is installed. The rows show the date and time of saved settings.

Press "OK" to confirm.

8.2.16 Load settings

The saved settings can be recovered.

Press "OK" to confirm.

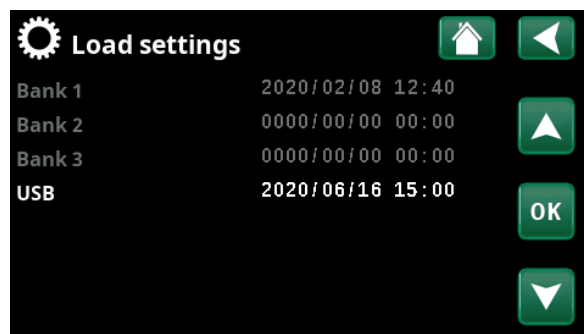

Menu: "Advanced/Settings/Load my settings".

8.2.17 Load Factory settings

The product is supplied with the factory values set. Saved settings in "Bank" 1-3 are deleted when factory settings are restored. The selected language is recovered.

Press "OK" to confirm.

8.3 Define



The "Define" menus specify which components and subsystems the system consists of.

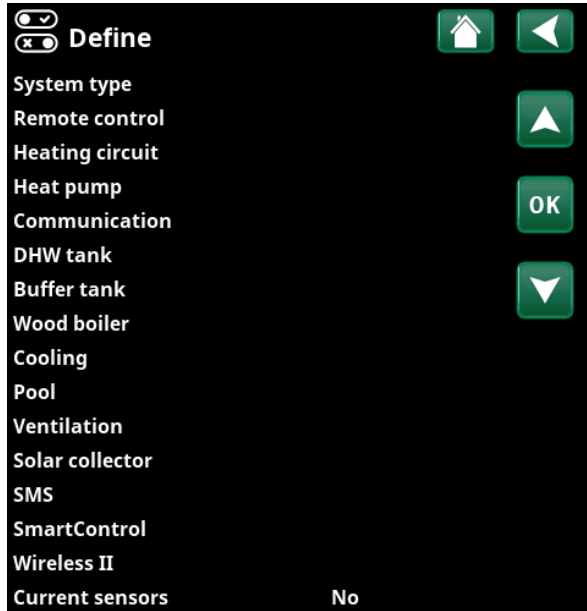

Menu: "Advanced/Define /Remote control".

8.3.1 Define, System type

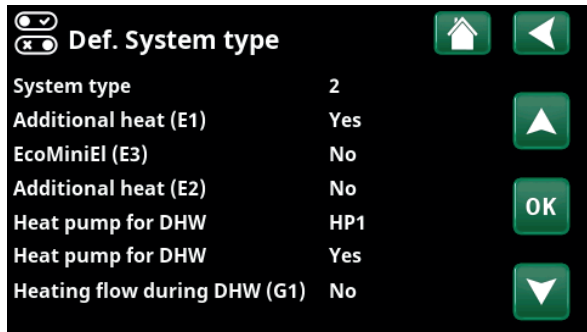

Menu: "Advanced/Define/System Type".

System type 2 (1/2/3/4/5/6)

Select system type 1-6. For more information about the six system types, see the "Pipe Installation" chapter.

Additional heat (E1) Yes (Yes/No)

Specify whether additional heat (E1) is connected.

The menu bar is displayed if system type 2, 3, 4, or 5 is defined.

Note that when E1 is used in system type 2, 3 and 4, heating circuit 2 cannot be installed because mixing valve Y2 is used to mix additional heat.

Also note that system type 5 does not have a mixing valve for additional heat (E1).

EcoMiniEl (E3) No (Yes/No)

Specify whether CTC EcoMiniEl is connected.

This menu bar is displayed if system type 2, 3 or 4 is defined.

Additional heat (E2) No (No/0-10V/0-1 step/0-3 steps/0-7 steps)

Specify whether additional heat E2 (0-10V/0-1 step/0-3 steps/0-7 steps) is connected.

This menu bar is displayed if system type 2, 3 or 4 is defined.

Heat pump for DHW HP1 (HP1/HP1+HP2)

This menu bar is displayed if system type 2-6 is defined.

Specify whether Heat Pump 1 (HP1) or both heat pumps (HP1+HP2) should be allowed to produce hot water.

Heat pump for DHW Yes (Yes/No)

This menu bar is displayed if system type 1 is defined.

Select "Yes" if the heat pump should prioritise DHW during the summer period when the status is DHW.

Heating flow during DHW (G1) No (Yes/No)

If system type 2 or 3 has been defined:

Specify if there is a need for heating flow during DHW production. This menu must be selected if pump G1 and by-pass connection are present.

If "Yes", a degree minutes calculation will also be performed during DHW charging.

If "Yes", priority is also given between heating and DHW production according to settings in the menu "Advanced/Settings/DHW tank".

This menu bar is displayed if system type 2 or 3 is defined.

If system type 5 has been defined:

If "Yes", priority is given between heating and DHW production according to settings in the menu "Advanced/Settings/DHW tank".

8.3.2 Define, Remote control

The "Advanced/Define/Remote control" menu describes all remote control functions, how they are set up and how they are used.

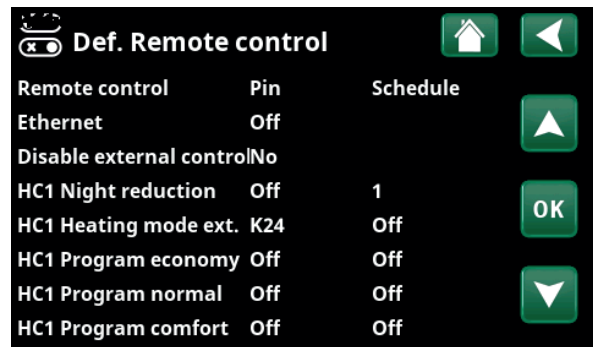

Part of the "Advanced/Define/Remote control" menu.

The remote control inputs can be activated by specifying one of the following three modes in the "Input" column:

- a terminal block K22-K23 on the relay board (A2) has power or terminal block K24-K25 is closed. There are two 230 V inputs and two low voltage ports.

Designation	Terminal block position	Connection type
K22	A14 & A25	230V
K23	A24 & A25	230V
K24	G33 & G34	Extra-low voltage (<12V)
K25	G73 & G74	Extra-low voltage (<12V)

The table shows the remote control inputs K22-K25 on the relay board.

- accessories in the CTC SmartControl series, consist of wireless sensors and control units that control signals for temperature, humidity and carbon dioxide levels.
- accessories in the CTC Wireless Room Sensor II series, consist of room unit and a base unit that control signals for temperature.
- BMS control where control signals are transmitted via the BMS interface.

If you want a function to recur during weekdays, you can set when the function should be active/inactive in a schedule.

8.3.2.1 Setting the remote control function

1. Define an "Input"

First, an input must be assigned to the function or functions to be controlled remotely.

In the example, terminal block K24 is selected as the input for the "HC1 Heating mode, ext." function.

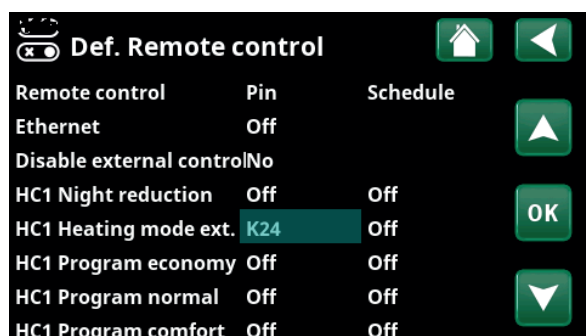

Menu: "Advanced/Define /Remote Control".

2. Configure the function

(Normally Open (NO)/Normally Closed (NC))

Define a normal mode for the external control signal; NO or NC. The setting is made for the current heating circuit in the "Advanced/Define/Heating Circuit" menu.

For example, a two-way switch can be connected to the defined input.

If the button when used generates a control signal on the input (circuit closes), the circuit shall be defined as NO. When the circuit closes and the control signal is generated, the heating mode selected in the "HC1 Heating mode, ext. config." row is activated in the settings menu for the heating circuit.

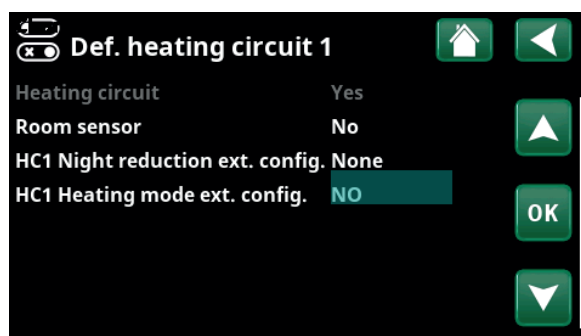

Menu: "Advanced/Define/Heating Circuit/ Heating Circuit 1".

3. Setting the heating mode

In the example, the remote control function "Heating mode, ext." is set to the "Off" position in the "Heating mode, ext." row. This setting is made in the "Advanced/Settings/heating circuit" menu.

In this example, the normal heating mode is active ("On").

When input K24 is closed (the multi-button in the example generates a control signal), the status of the Heating Mode (normal mode "On" > mode "Off") changes.

Heating remains off until you choose to start the heating (normal mode "On") by opening terminal block K24 (no signal on the terminal block).

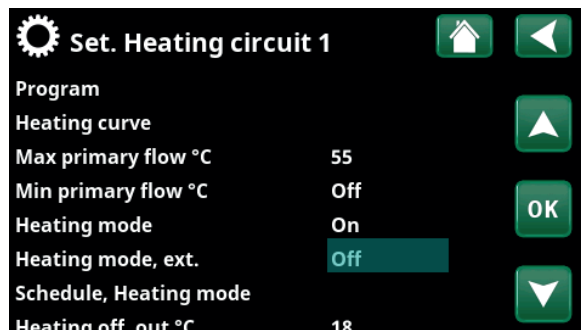

Menu: "Advanced/Settings/Heating Circuit/Heating Circuit 1". Remote control mode "Off" becomes active when terminal block K24 is closed.

Heating mode "On" = Open terminal block.
 Heating mode "Off" = Closed terminal block (in this example).

8.3.2.2 Remote control functions

The "Advanced/Define/Remote Control" menu defines Inputs for current remote control functions:

- terminal blocks K22, K23, K24, K25.
- wireless accessories in the SmartControl/Wireless II series (Channel 1A, 1B, 2A, 2B, 3A, 3B and so on up to 7B).
- BMS digital input 0-7. Specify a value 0-255. The value must be set again within half an hour for the setting to persist.

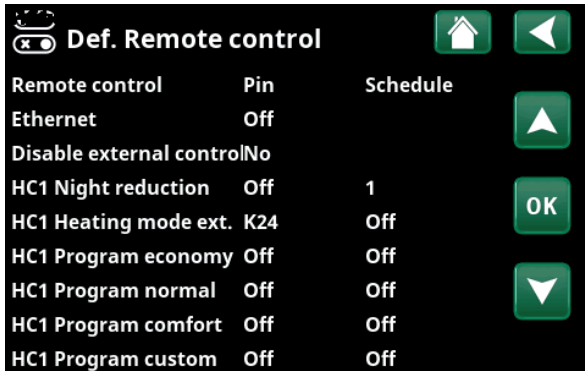

Part of the "Advanced/Define/Remote control" menu. "Input" and "Schedule" are defined here.

Ethernet (Modbus TCP/Off)

For information about Modbus TCP Port settings, see the "Communication" section in the "Advanced/Settings" chapter.

Disable external control (Yes/No)

Selection "Yes" means disconnecting all external control of the heat pump. Schedule settings are not affected.

HC1-* Night reduction

The "Night Reduction" function can be used to, for example, lower the indoor temperature during the night or during working hours.

In the "Advanced/Define/Remote Control" menu:

- specify an "Input" for the remote control function.

In the "Advanced/Define/Heating Circuit" menu:

- configure the normal mode for the external control signal (Normally Open (NO)/Normally Closed (NC)).

The schedule can be set in the "Heating/Cooling" menu.

For more information, see the "Night Reduction Temperature" section in the "Heating/Cooling" chapter.

HC1-* Heating mode, ext.

Switching between heating season and summer season can take place at a specific outdoor temperature (Auto) or heating can be either always "On" or "Off".

In the "Advanced/Define/Remote Control" menu:

- specify an "Input" for the remote control function.

In the "Advanced/Define/Heating Circuit" menu:

- configure the normal mode for the external control signal (Normally Open (NO)/Normally Closed (NC)).

In the "Advanced/Settings/Heating Circuit" menu:

- set "Remote Control Mode" ("On", "Off" or "Auto") in the "Heating mode, ext." row.
- Access function scheduling from the "Schedule, Heating mode" row.

For more information, see the "Heating Circuit" section in the "Advanced/Settings" chapter.

Also see the "House heating settings" chapter.

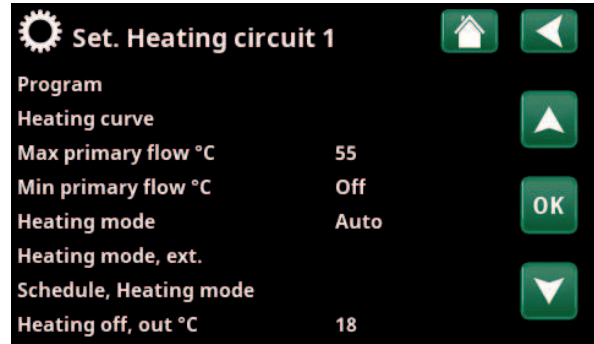

Menu: "Advanced/Settings/Heating circuit".

HC1-* Program Economy/Normal/Comfort/Custom

The program functions "Economy", "Normal" "Comfort" and "Custom" can be used to change the indoor temperature for a certain period.

In the "Advanced/Define/Remote Control" menu:

- specify an "Input" for the remote control function.

In the "Advanced/Define/Heating circuit":

- configure the normal mode for the external control signal (Normally Open (NO)/Normally Closed (NC))

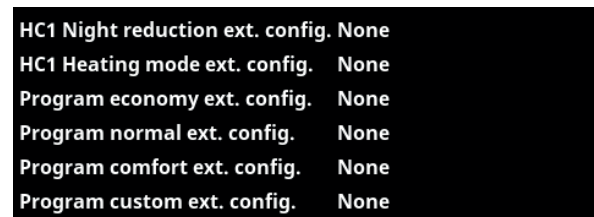

Menu "Advanced/Define/Heating circuit".

Setting the schedule is done from the "Heating/Cooling/Program" menu.

For more information, see section "Heating program" in chapter "Heating/Cooling".

Drying period

Floor drying function for newly built properties.

In the "Advanced/Define/Remote Control" menu:

- specify an "Schedule" (Off/1...20) for the remote control function.

For more information and settings, see section "Drying period" in chapter "Settings/Heating circuit".

**The number of possible heating circuits or heat pumps that can be connected to the system varies depending on the control system.*

Extra DHW

Upon activation, production of extra DHW begins. When activation stops, extra DHW is produced for a run-on time of 30 min. The "Stop temperature" for extra DHW is set in the "Advanced/Settings /DHW Tank/DHW program" menu.

In the "Advanced/Define/Remote Control" menu:

- specify an "Input" for the remote control function.

In the "Advanced/Define/DHW Tank" menu:

- configure the normal mode for the external control signal (Normally Open (NO)/Normally Closed (NC)).

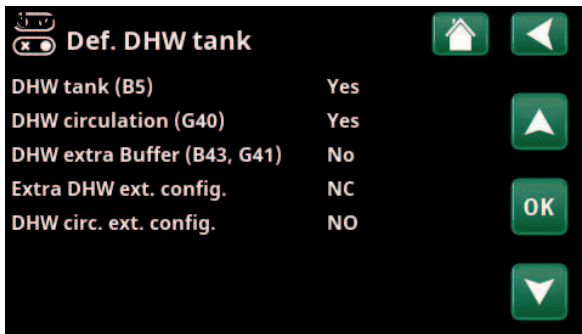

Menu: "Advanced/Define/DHW tank".

Setting extra DHW production to start immediately can also be done in the "DHW" menu. The schedule for extra DHW can also be set in this menu.

For more information, see the "Extra DHW" section in the "DHW" chapter.

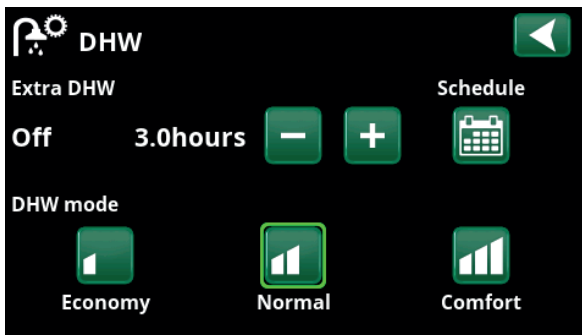

Setting the "Extra DHW" in the "DHW" menu.

Block Cooling

In the "Advanced/Define/Remote Control" menu:

- specify an "Input" for the remote control function.

In the "Advanced/Define/Cooling" menu:

- configure the normal mode for the external control signal (Normally Open (NO)/Normally Closed (NC)).

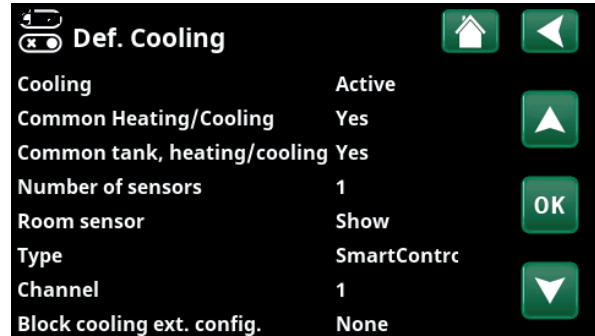

Menu "Advanced/Define/Cooling".

In the "Advanced/Settings/Cooling" menu:

- set the remote control mode ("Yes") in the "Ext. block cooling" row.
- Access function scheduling from the "Schedule, Blocking cooling" row.

For more information, see the "Cooling" section in the "Advanced/Settings" chapter.

Block Pool

This function is used to block pool heating.

In the "Advanced/Define/Remote Control" menu:

- specify an "Input" for the remote control function.

In the "Advanced/Define/Pool" menu:

- configure the normal mode for the external control signal (Normally Open (NO)/Normally Closed (NC)).

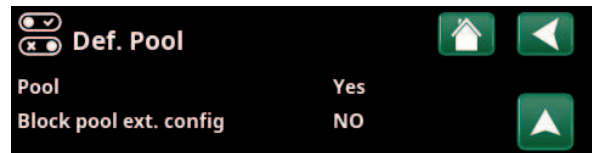

Menu: "Advanced/Define/Pool".

In the "Advanced/Settings/Pool" menu:

- set the "remote control mode" ("On") in the "Blocking Pool" row.
- Access function scheduling from the "Schedule, Block pool" row.

For more information, see the "Pool" section in the "Advanced/Settings" chapter.

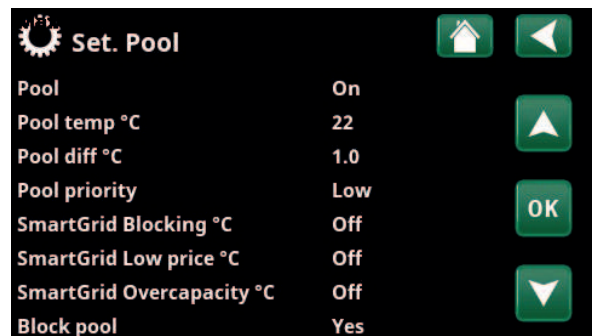

Menu: "Advanced/Settings/Pool".

Activate this function via an external control signal or a schedule.

Tariff EL

This function is used to block the immersion heater during periods when the electricity rate is higher.

In the "Advanced/Define/Remote Control" menu:

- specify an "Input" for the remote control function.

In the "Advanced/Settings/Additional Heat" menu:

- set "remote control mode" ("Yes") in the "Tariff EL" row.
- Access function scheduling from the "Tariff EL" row.

For more information, see the "Additional Heat/Tariff EL" section in the "Advanced/Settings" chapter.

Conv. factor curr. sensors	1
Tariff EL	No
Schedule, Tariff EL	

Menu: "Advanced/Settings/Additional heat".
Setting "Tariff EL" via an external control signal or a schedule.

Round circulation

Round circulation is an equipment that the electricity supplier can mount, for a shorter time, to disconnect power-intensive equipment. Compressor and electric power are blocked when round circulation is active.

In the "Advanced/Define/Remote Control" menu:

- specify an "Input" for the remote control function.

In the "Advanced/Settings" menu:

- Access function scheduling from the "Round circ. schedule" row.

For more information, see the "Round circulation" section in the "Advanced/Settings" chapter.

Current sensors
Round circ. schedule
SmartGrid Schedule

Menu: "Advanced/Settings". Setting a "Round circulation" schedule.

DHW circulation

The function allows DHW to circulate in the pipes between the taps and the DHW tank, ensuring that the DHW is hot when the taps are opened.

In the "Advanced/Define/Remote Control" menu:

- specify an "Input" for the remote control function.

In the "Advanced/Define/DHW Tank" menu:

- configure the normal mode for the external control signal (Normally Open (NO)/Normally Closed (NC)) in the "DHW circ. ext. config." row.

Def. DHW tank			
DHW tank (B5)	Yes		
DHW circulation (G40)	Yes		
DHW extra Buffer (B43, G41)	No		
Extra DHW ext. config.	NC		
DHW circ. ext. config.	NO		

Menu: "Advanced/Define/DHW tank".

In the "Advanced/Settings/DHW Tank" menu:

- Access function scheduling from the "Schedule, DHW circulation" row.

For more information, see the "DHW Tank" section in the "Advanced/Settings" chapter.

Run time DHW circ. (min.)	4
Period time DHW circ. (min.)	15
Diff start ext DHW tank	5
Schedule, DHW circulation	

Menu: "Advanced/Settings/DHW tank".
Setting a "DHW circulation" schedule.

Buffer tank

The buffer tank helps to maintain a more even temperature in the heating circuit.

In the "Advanced/Define/Remote Control" menu:

- specify an "Input" for the remote control function.

In the "Advanced/Define/Buffer Tank" menu:

- configure the normal mode for the external control signal (Normally Open (NO)/Normally Closed (NC)) in the "Buffer tank ext. config." row.

Def. Buffer tank			
Buffer tank ext. config.	NC		

Menu: "Advanced/Define/Buffer tank".

In the "Advanced/Settings/Buffer Tank" menu:

- Access function scheduling from the "Schedule, Buffer tank" row.

For more information, see the "Buffer Tank" section in the "Advanced/Settings" chapter.

Set. Buffer Tank			
Reactive power	55		
Tank min °C	30		
Diff tank vs primary °C	0		
Start/stop diff tank °C	5		
Setpoint schedule °C	50		
Schedule, Buffer tank			
SmartGrid Low price °C	Off		
SmartGrid Overcapacity °C	Off		

Menu: "Advanced/Settings/Buffer tank".
Activate this function via an external control signal or a schedule.

Flow/level switch

The flow/level switch produces an alarm on the heat pump.

In the "Advanced/Define/Remote Control" menu:

- specify an "Input" for the remote control function.

In the "Advanced/Define/Heat Pump" menu:

- configure the normal mode for the external control signal (Normally Open (NO)/Normally Closed (NC)) in the "Flow/level switch" row.

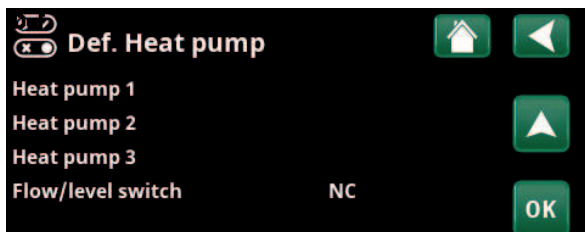

Menu: "Advanced/Define/Heat pump".

SmartGrid A / SmartGrid B

In the "Advanced/Define/Remote Control" menu:

- specify an "Input" for the remote control function.

There are three SmartGrid functions:

- SmartGrid Low Price
- SmartGrid Overcapacity
- SmartGrid Blocking

Example of "SmartGrid Low Price" for pool heating

In this example, "SmartGrid A" and "SmartGrid B" have been assigned terminal blocks K22 and K23, respectively. In addition, SmartGrid A is assigned "Schedule #1".

According to the settings in the "Set. Pool" menu, the pool setpoint will be increased by 5 °C when the electricity price is low (when the "SmartGrid Low price" function is active) and the setpoint will be decreased by 10°C* when the electricity price is high (when the "SmartGrid Blocking" function is active).

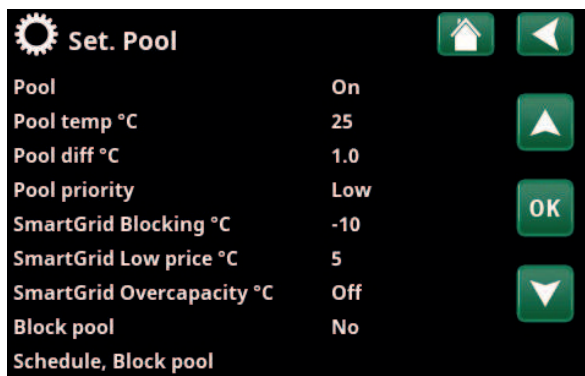

Menu: "Advanced/Settings/Pool".

The pool temperature is increased by 5 °C when the SmartGrid Low Price function is activated.

SmartGrid functions can be set (depending on system configuration/heat pump model) for Heating circuit including Heating program economy/comfort/custom, Heat pumps, Additional heating, Cooling, Pool, DHW tank, Buffer tank and Upper* and Lower* tank.

Heating circuit 1-*

- SmartGrid Blocking (Off/On)
- SmartGrid Low price °C (Off/1...5 °C)
- SmartGrid Overcapacity °C (Off/1...5 °C)

Heating program

-Comfort:

- SmartGrid Low price °C (Off/On)
- SmartGrid Overcapacity °C (Off/On)

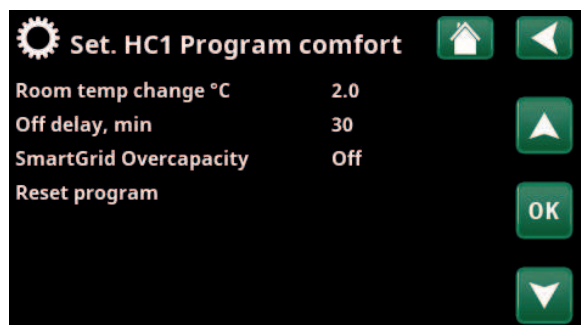

Menu "Advanced/Settings/Heating circuit/Heating circuit 1/Program/Comfort".

-Custom:

- SmartGrid Low price °C (Off/On)
- SmartGrid Overcapacity °C (Off/On)
- SmartGrid Blocking (Off/On)

-Economy:

- SmartGrid Blocking (Off/On)

Heat pump*

- SmartGrid Blocking HP (Yes/No)

Additional Heat/Immersion heater

- SmartGrid Blocking EL (Yes/No)
- SmartGrid Blocking Mixing valve (Yes/No)

Cooling

- SmartGrid Low Price °C (Off/1...5 °C)
- SmartGrid Overcapacity °C (Off/1...5 °C)

Pool

- SmartGrid Blocking °C (Off/-1...-50 °C)
- SmartGrid Low Price °C (Off/1...50 °C)
- SmartGrid Overcapacity °C (Off/1...50 °C)

DHW tank/Lower tank/Upper tank

- SmartGrid Blocking °C (Off/-1...-50 °C)
- SmartGrid Low Price °C (Off/1...30 °C)
- SmartGrid Overcapacity °C (Off/1...30 °C)

*The number of possible heating circuits or heat pumps that can be connected to the system varies depending on the control system.

Buffer tank

- SmartGrid Low Price °C (Off/1...30 °C)
- SmartGrid Overcapacity °C (Off/1...30 °C)

SmartGrid functions are enabled by activating the SmartGrid inputs in different ways according to the table.

K22 (SG A)	K23 (SG B)	Function
Open	Open	Normal
Open	Closed	Low price
Closed	Closed	Overcapacity
Closed	Open	Blocking

To enable the SmartGrid function "SG Low Price" as shown in the example, terminal block K23 must have power while terminal block K22 should remain unchanged.

The pool temperature increase that will apply when "SG Low Price" is activated is set in the "Pool Settings" menu, as shown in the example.

Alternatively, a schedule can be set up for periodic SmartGrid activation. See the "Schedule" chapter for more information.

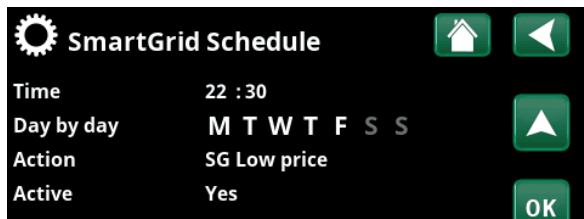

The schedule is set to start at 22:30, weekdays.

Vent. Reduced/Vent. Normal/Vent. Boost/Vent. Custom/Vent. Away

When there is a signal in the respective ventilation function's remote control input, the selected ventilation mode will start and be active for half an hour.

In the "Advanced/Define/Remote Control" menu:

- specify and "Input" for current ventilation functions.

Click the Ventilation symbol in the start menu to access the "Ventilation" menu, where ventilation settings can be made. The schedule can also be accessed from there. However, a schedule cannot be specified for the "Vent. Away" ventilation mode.

For more information, please see the CTC EcoVent ventilation product manual.

HP1-* Tariff

This function is used to block the heat pump during periods when the electricity rate is higher.

In the "Advanced/Define/Remote Control" menu:

- specify an "Input" for the remote control function.

In the "Advanced/Define/Heat Pump" menu:

- configure the normal mode for the external control signal (Normally Open (NO)/Normally Closed (NC)) in the "Tariff HP ext. config." row.

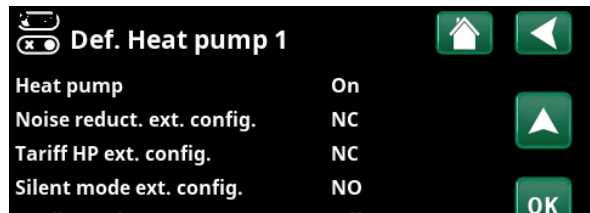

Menu: "Advanced/Define/Heat pump".

In the "Advanced/Settings/Heat Pump/Heat Pump (1-)*" menu:

- set "Tariff HP" ("On").

For more information, see the "Heating Pump" section in the "Advanced/Settings" chapter.

HP1-* Noise Reduction

This function can be used to reduce compressor speed in order to reduce the noise level.

In the "Advanced/Define/Remote Control" menu:

- specify an "Input" for the remote control function.

In the "Advanced/Define/Heat Pump" menu:

- configure the normal mode for the external control signal (Normally Open (NO)/Normally Closed (NC)) in the "Noise reduction ext. config." row.

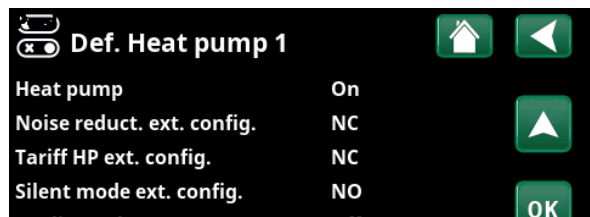

Menu: "Advanced/Define/Heat pump".

In the "Advanced/Settings/Heat Pump/Heat Pump 1*" menu:

- in the "Ext. Noise reduction RPS" row, set the compressor speed value applicable for remote control.

For more information, see the "Heating Pump" section in the "Advanced/Settings" chapter.

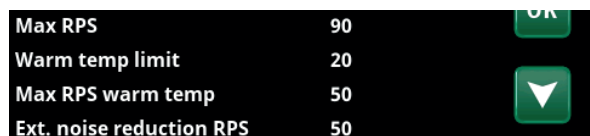

Menu: "Advanced/Settings/Heat pump /Heat pump 1-".

**The number of possible heating circuits or heat pumps that can be connected to the system varies depending on the control system.*

HP1-* Silent Mode

This function can be used to reduce compressor speed and fan speed in order to reduce the noise level.

Only applies to certain air-to-water heat pumps

In the "Advanced/Define/Remote Control" menu:

- specify an "Input" for the remote control function.

In the "Advanced/Define/Heat Pump" menu:

- configure the normal mode for the external control signal (Normally Open (NO)/Normally Closed (NC)) in the "Silent mode ext. config." row.

For more information, see the "Heating Pump" section in the "Advanced/Settings" chapter.

Power limitation

Power limitation can be used, for example, if the if the electricity grid operator requires control of the electricity grid load. The function can limit the operating power of the compressor and the immersion heater.

In the "Advanced/Define/Remote Control" menu:

- specify an "Input" for the remote control function.

In the "Advanced/Define/Communication" menu:

- configure the normal mode for the external control signal (Normally Open (NO)/Normally Closed (NC)) in the "Power limitation ext. config." row.

In the "Advanced/Settings/Power limitation" menu:

- Access function scheduling from the "Schedule" row.

For more information, see the "Power limitation" section in the "Advanced/Settings" chapter.

**The number of possible heating circuits or heat pumps that can be connected to the system varies depending on the control system.*

8.3.3 Define, Heating circuit

Heating circuit 1-* **Yes (Yes/No)**

Heating circuit 1 (HC1) is predefined.

The rows under Heating Circuit 1 show the other definable heating circuits (HC 2-3 in the example).

The heating circuits shown depend, among other things, on which heating circuits are part of the defined System Type (1-6).

It is possible to deactivate heating system 1. In system types 4-6, only one buffer tank is provided with a temperature according to the setpoint.

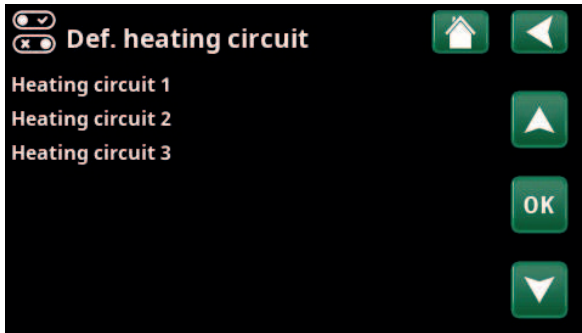

Menu: "Advanced/Define/Heating circuit".
Select a heating circuit and press "OK" to access the settings.

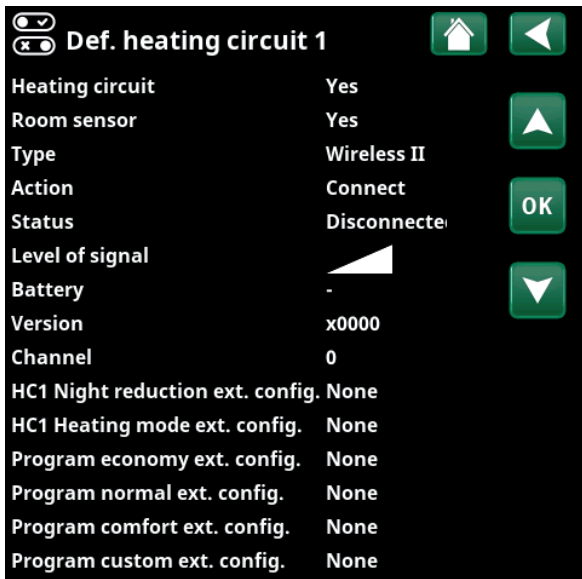

Menu: "Advanced/Define/Heating circuit/Heating circuit 1". Wireless room sensor II is selected.

Room sensor **Yes (Yes/No/Show)**

Selection "Yes" means that room sensors should be connected to the heating circuit.

If "Show" is selected, the room temperature is displayed but the room sensor is not used for control.

Type **Cable/Wireless/Wireless II/SmartControl**

Select whether the room sensor for the heating circuit has a wired (via cable) or wireless connection.

- **Cable**
Wired room sensor.
- **Wireless**
Select "Wireless" to connect CTC's wireless room sensors to the heating circuit.
See the "CTC Wireless Room Sensor" manual for information on how to connect these sensors.
- **Wireless II**
Select "Wireless II" to connect CTC's wireless room sensor II to the heating circuit.
See the "CTC Wireless Room Sensor II" manual for information on how to connect these sensors.
- **SmartControl**
CTC SmartControl is a separate series of wireless accessories. If "SmartControl" is selected, the connection channel must be selected in the row below. CTC SmartControl accessories are connected to the system via the "Advanced/Define/SmartControl" menu. Refer to the separate CTC SmartControl Accessories manual.

HC1- Night reduction ext. config. **None (None/NO/NC)**

This menu defines the Normally Open (NO) or Normally Closed (NC) mode for the external control signal when remotely controlling the function.
For examples of normal mode settings, refer to the "Def. Remote Control" section of the "Advanced/Define" chapter.

HC1- Heating mode ext. config. **None (None/NO/NC)**

This menu defines the Normally Open (NO) or Normally Closed (NC) mode for the external control signal when remotely controlling the function.
For examples of normal mode settings, refer to the "Def. Remote Control" section of the "Advanced/Define" chapter.

Program ** ext. config. **None (None/NO/NC) **economy/normal/comfort/custom**

This menu defines the Normally Open (NO) or Normally Closed (NC) mode for the external control signal when remotely controlling the function.
For examples of how to set the normal mode, refer to the "Advanced/Define/Remote Control" chapter.

*The number of possible heating circuits or heat pumps that can be connected to the system varies depending on the control system.

8.3.4 Define, Heat pump

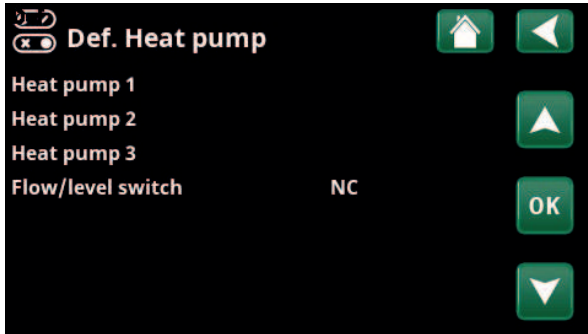

Menu: "Advanced/Define/Heat pump". Select a heat pump and press "OK" to access the settings.

Heat pump 1-* **On/Off**

Select a heat pump to be connected to the system and press "OK" to access the settings.

Flow/level switch **NC (None/NC/NO)**

This menu bar is displayed if an "Input" for remote control is defined for the "Flow/level switch" function in the "Advanced/Define/Remote Control" menu.

8.3.4.1 Define, Heat pump 1

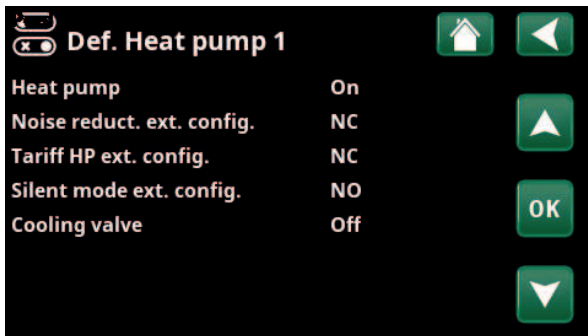

Menu: "Advanced/Define/Heat pump/Heat pump 1".

Heat pump **On/Off**

Select "On" to connect the heat pump to the system.

Noise reduct. ext. config. **NC (None/NC/NO)**

This menu bar is displayed if an "Input" for remote control is defined for the "HP Noise Reduction" function in the "Advanced/Define/Remote Control" menu.

Tariff HP ext. config. **NC (None/NC/NO)**

This menu bar is displayed if an "Input" for remote control is defined for the "HP Tariff" function in the "Advanced/Define/Remote Control" menu.

Silent mode ext. config.** **NO (None/NC/NO)**

This menu bar is displayed if an "Input" for remote control is defined for the "Silent Mode" function in the "Advanced/Define/Remote Control" menu.

Cooling valve **Off (Off/On)**

Select whether the cooling valve is to be "On" or "Off".

8.3.5 Define, Communication

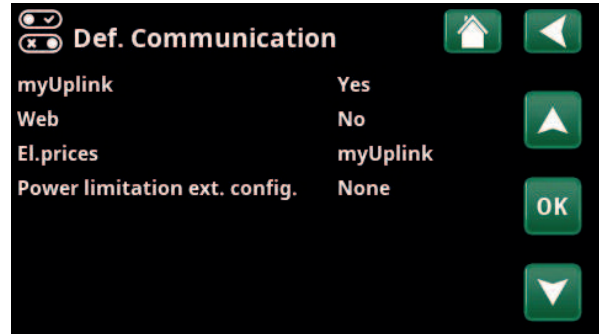

Menu: "Advanced/Define/Communication".

myUplink **No (Yes/No)**

Select "Yes" to connect to the heat pump from the myUplink app

Web **No (Yes/No)**

Select "Yes" to connect to the local web server. Internet router and firewall required.

El.prices **myUplink/myUplink ext./BMS/No**

Select "myUplink" to connect the heat pump to the myUplink mobile app for electricity price control.

Select "myUplink ext." to connect via myUplink to an external price control app. This option is not available at the moment.

Select "BMS" to connect via property management.

Power limitation ext. config. **None (None/NC/NO)**

This menu bar is displayed if an "Input" for remote control is defined for the "Power limitation" function in the "Advanced/Define/Remote Control" menu.



For more information, see the "Installation Communication" chapter of this manual.

*The number of possible heating circuits or heat pumps that can be connected to the system varies depending on the control system.

*Only applies to certain air-to-water heat pumps.

8.4 Cascade connection

8.4.1 Define number of heat pumps

Define the heat pumps: "Advanced/Define/Heat pump".

Set the heat pumps contained in the system to position "On".

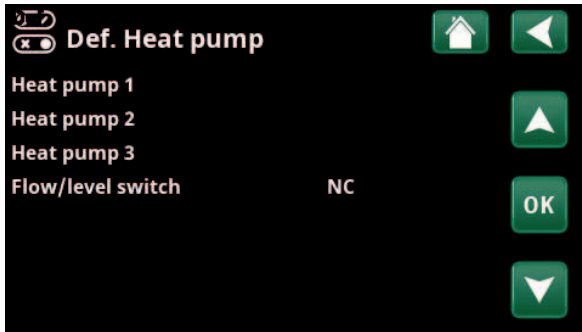

Example of a system with 3 heat pumps.

- Go to "Advanced/Service/Set Address".

Select "Current address", press OK. Press the up/down arrow until the current heat pump appears (HP1). Press OK.

Select "New address", press OK. Press the up/down arrow until the current address for the heat pump appears (HP2). Press OK.

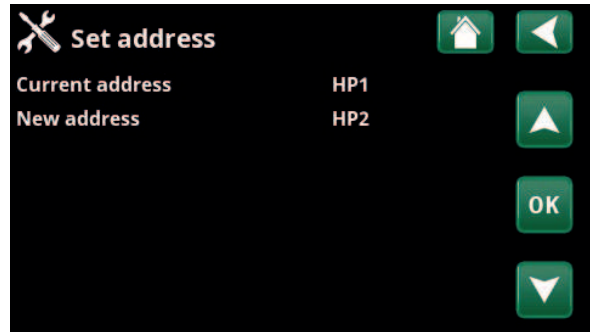

8.4.2 Numbering control system as HP2

- System disconnected from power.

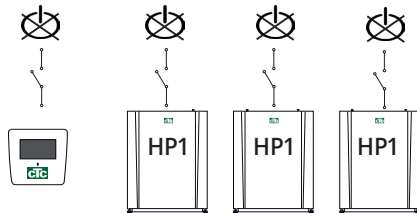

- Energise the control as well as the heat pump to be numbered as Heat Pump 2 (HP2).

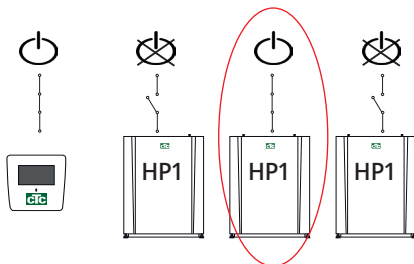

- Wait for about 2 minutes.

- The heat pump is now numbered (HP2).

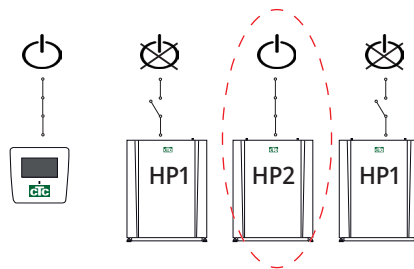

When you press OK, (HP1 and HP2)* disappears and the row "Current address/New Address" will go dark.

**In this example, we have assumed that the heat pump is called HP1, which is the factory default. If the heat pump has already been renumbered, then select this number instead.*

- Number the next heat pump:

Energise the next heat pump, which will be numbered heat pump 3 (HP3).

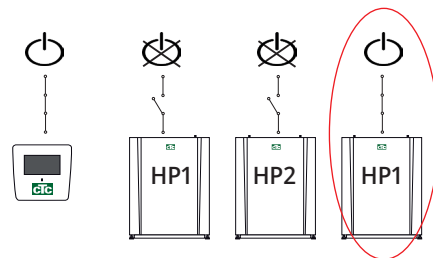

- Wait for about 2 minutes.

- Go to "Service/Set Address".

Select "Current address", press OK. Press the up/down arrow until the current heat pump appears (HP1). Press OK.

Select "New address", press OK. Press the up/down arrow until the current address for the heat pump appears (HP3). Press OK.

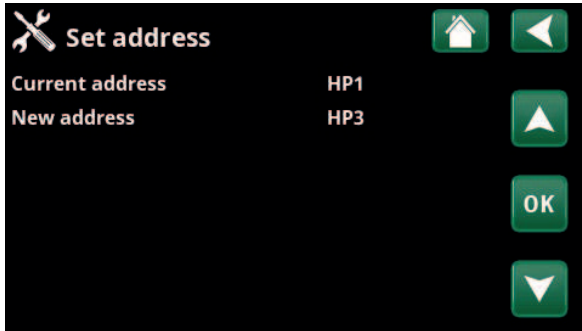

- The heat pump is now numbered (HP3).

When you press OK, (HP1 and HP3)* disappears and the row "Current address/New Address" will go dark.

**In this example, we have assumed that the heat pump is called HP1, which is the factory default. If the heat pump has already been renumbered, then select this number instead.*

- Redo the procedure according to the number of heat pumps to be numbered.

When all heat pumps are numbered and energised, they should be displayed when you press the heat pump symbol in the menu "Operation data". If any heat pump does not appear in the menu (communication with the heat pump fails) It may be because it has not been numbered as described above.

If you do not know the name of the heat pump, you can reset the numbering by using the "Select/Rename Heat Pump" menu (refer to points 9 and 10 above) to indicate all possible names of the heat pump, i.e. you select and confirm HP1 and then HP2 up to HP10 to ensure that the correct name is given.

Finally test in the menu "Advanced/Service/Function test/Heat pump" that the respective heat pump starts.

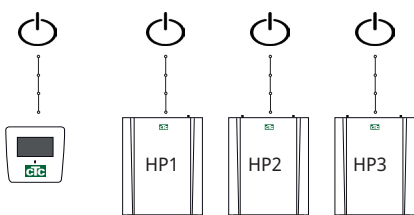

8.4.3 Worth knowing when addressing

Error set Address

The heat pump could not be found and numbered.

The heat pump was not what it was supposed to be called.

No communication with the heat pump.

Check that the heat pump is energised.

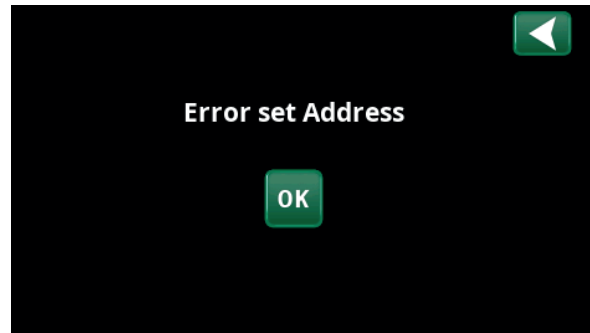

If the setting of the address fails, the latest heat pump addresses remain. In this example HP1 and HP2.

Make sure the heat pump is energised.

Try again with a new current address.

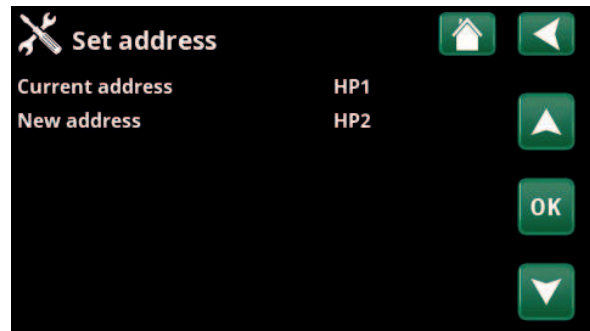

8.4.4 Define, DHW tank

This menu bar is displayed if "System Types" 2-6 are selected in the "Advanced/Define/System Type" menu ("System Type 1" does not include the DHW tank).

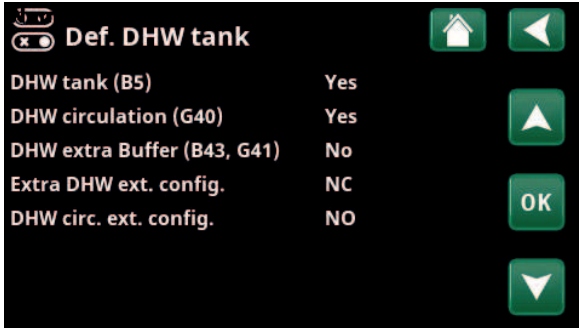

Menu: "Advanced/Define/DHW Tank".

DHW tank (B5) Yes (Yes/No)
Specify whether sensor (B5) in the DHW tank is connected.

Number of sensors 1/2
This menu bar is displayed if "System Types" 2-6 are selected in the "Advanced/Define/System Type" menu ("System Type 1" does not include the DHW tank).

DHW circulation (G40)* Yes (Yes/No)
Specify whether the circulation pump (G40) is connected to the DHW system.

DHW extra Buffer (B43, G41)* No (Yes/No)
Specify whether the circulation pump (G41) and external DHW tank sensor (B43) are connected to the DHW system.

Extra DHW ext. config. NC (None/NC/NO)
This menu defines the (Normally Open (NO) or Normally Closed (NC)) mode for the external control signal when remotely controlling the function.

For examples of normal mode settings, refer to the "Def. Remote Control" section of the "Advanced/Define" chapter.

DHW circ. ext. config. NO (None/NC/NO)
This menu bar is displayed if "DHW circulation (G40)" is defined as above.

This menu defines the (Normally Open (NO) or Normally Closed (NC)) mode for the external control signal when remotely controlling the function.

For examples of normal mode settings, refer to the "Def. Remote Control" section of the "Advanced/Define" chapter.

8.4.5 Define, Buffer tank

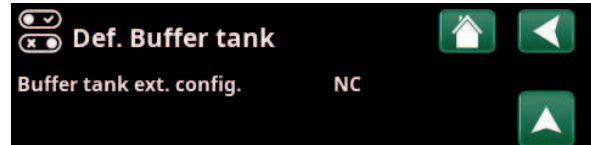

Menu: "Advanced/Define/Buffer Tank".

Buffer tank ext. config. NC (None/NC/NO)

This menu bar is displayed if "System Types" 4-6 are selected in the "Advanced/Define/System Type" menu ("System Type 1-3" does not include the buffer tank).

This menu defines the (Normally Open (NO) or Normally Closed (NC)) mode for the external control signal when remotely controlling the function.

For examples of normal mode settings, refer to the "Def. Remote Control" section of the "Advanced/Define" chapter.

Number of sensors 1/2

This menu bar is displayed if "System Types" 4-6 are selected in the "Advanced/Define/System Type" menu ("System Type 1" does not include the buffer tank).

8.4.6 Define, Wood boiler

This menu bar is displayed if "System Type 1" is selected in the "Advanced/Define/System Type" menu ("System Types 2-6" do not include "Wood Boiler").

Select "Yes" in the "Wood Boiler" row if wood is to be burned and the flue gas sensor (B8) is connected to the system.

*Applies to CTC EcoLogic XL/L.

8.4.7 Define, Cooling

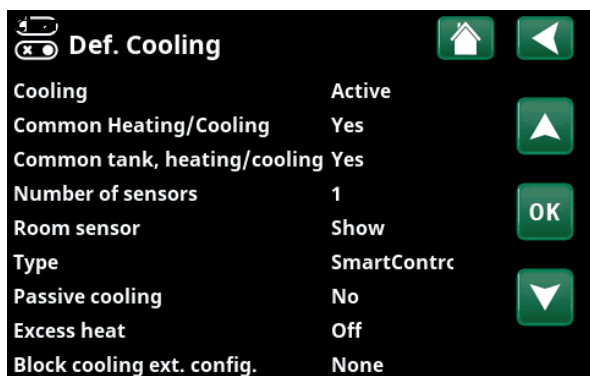

Menu: "Advanced/Define/Cooling".

Cooling No (Passive/No/Active/Active brine cool.)

"Passive" means that free cooling is used. "Active" means that the compressor produces cooling. "Active, brine cooling" means that the low temperature of the brine circuit is utilised but also actively cooled by the heat pump.

Common Heating/Cooling* No (Yes/No)

Selection "Yes" means that heating and cooling are distributed in the same heating circuit.

Common tank, heating/cooling* No (Yes/No/No tank/Only tank)

Selection "Yes" means that heating and cooling are distributed in the same tank.

Selection "No" means that cooling is distributed in the tank.

Selection "No tank" means that there is no tank in the system.

The selection "Only tank" is used to cool the tank. The temperature towards the cooling circuits must be controlled by an external controller (not from CTC).

Number of sensors 1/2

This menu bar is displayed if "System Types" 2-5 are selected in the "Advanced/Define/System Type" menu ("System Type 1" does not include the DHW tank).

Room sensor Yes (Yes/No/Show)

Selection "Yes" means that room sensors should be connected to the heating circuit.

If "Show" is selected, the room temperature is displayed but the room sensor is not used for control.

! A room sensor must always be used in that part of the property which is to be cooled, as it is the room sensor which determines/controls cooling capacity.

Type Cable/Wireless/Wireless II/SmartControl

Select whether the room sensor for the heating circuit has a wired (via cable) or wireless connection.

- **Cable**
Wired room sensor.
- **Wireless**
Select "Wireless" to connect CTC's wireless room sensors to the heating circuit. See the "CTC Wireless Room Sensor" manual for information on how to connect these sensors.
- **Wireless II**
Select "Wireless II" to connect CTC's wireless room sensor II to the heating circuit. See the "CTC Wireless Room Sensor II" manual for information on how to connect these sensors.
- **SmartControl**
CTC SmartControl is a separate series of wireless accessories. If "SmartControl" is selected, the connection channel must be selected in the row below. CTC SmartControl accessories are connected to the system via the "Advanced/Define/SmartControl" menu. See the separate CTC SmartControl accessories manual.

Passive cooling No (Yes/No)**

Selection "Yes" means that passive cooling is used in combination with active brine cooling. A diverting valve for heat dumping must be installed in the system.

Excess heat Off (Off/Borehole/Fan convector)**

Selection "Borehole" means that excess heat is dumped into the borehole.

Selection "Fan convector" means that the excess heat is dumped into the outdoor air via a fan convector.

Block cooling ext. config. None (None/NC/NO)

This menu bar is displayed if an "Input" for remote control is defined for the "Block Cooling" function in the "Advanced/Define/Remote Control" menu.

The function can be used to turn off cooling with the help of a humidity sensor when there is a risk of condensation.

This menu defines the Normally Open (NO) or Normally Closed (NC) mode for the external control signal when remotely controlling the function.

For examples of normal mode settings, refer to the "Def. Remote Control" section of the "Advanced/Define" chapter.

**This menu bar is only displayed if active cooling has been defined in the "Advanced/Define/Cooling" menu.*

***The menu bar is only displayed if active brine cooling has been defined in the "Advanced/Define/Cooling" menu.*

8.4.8 Define, Pool*



Menu: "Advanced/Define/Pool".

Pool **No (Yes/No)**

Select "Yes" to connect the pool if circulation pumps (G50) and (G51) and pool sensor (B50) are connected to the system.

Block pool ext. config **NO (None/NC/NO)**

This menu bar is displayed if an "Input" for remote control is defined for the "Block Pool" function in the "Advanced/Define/Remote Control" menu.

This menu defines the Normally Open (NO) or Normally Closed (NC) mode for the external control signal when remotely controlling the function.

For examples of normal mode settings, refer to the "Def. Remote Control" section of the "Advanced/Define" chapter.

8.4.9 Define, Ventilation

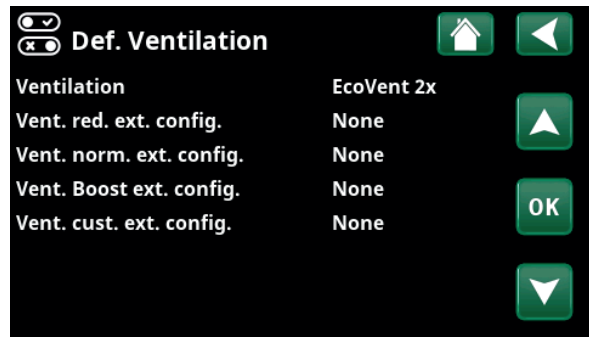

Menu: "Advanced/Define/Ventilation".

Ventilation **EcoVent 2x (EcoVent 2x/No)**

This defines whether the CTC EcoVent ventilation product is to be connected to the system.

The menus below define the Normally Open (NO) or Normally Closed (NC) mode for the external control signal when remotely controlling the function. This menu bar is displayed for the functions for which an "Input" for remote control is defined.

Vent. Red. ext. config. **None (None/NC/NO)**

Setting for the "Reduced" ventilation mode.

Vent. Norm. ext. config. **None (None/NC/NO)**

Setting for the "Normal" ventilation mode.

Vent. Boost ext. config. **None (None/NC/NO)**

Setting for the "Boost" ventilation mode.

Vent. Cust. ext. config. **None (None/NC/NO)**

Setting for the "Custom" ventilation mode.

For examples of normal mode settings, refer to the "Def. remote control" section in the "Advanced/Define" chapter.

Refer also to the "Installation and Maintenance Manual" for CTC EcoVent.

*Applies to CTC EcoLogic XL/L.

8.4.10 Define, Solar collector*

Parameter	Value
Solar collector	No
Type	Only DHW
Vacuum	No
Recharge borehole (Y31/G31)	No
Heat exchanger	No

Menu: "Advanced/Define/Solar collector".

Solar collector **No (Yes/No)**

Select "Yes" to connect solar collectors if the circulation pump (G30) as well as the "In" solar panel collector (B30) and "Out" solar collector sensor (B31) are connected to the system.

Type

Specify whether the solar energy heat should be supplied:

- DHW tank only ("Only DHW").
- buffer tank only ("Only Buffer").
- hot water and buffer tank ("DHW and Buffer").
- boiler only ("Boiler").

If this is selected, the solar collectors will pre-heat the hot water in the boiler.

Only shown for System Type 1.

Vacuum **No (Yes/No)**

Specify whether the solar collectors are vacuum or flat solar panels.

Recharge borehole (Y31/G31) **No (Yes/No)**

There is an option of recharging the borehole using energy from the solar collectors when the ordinary heating and domestic DHW needs have been met.

*Applies to CTC EcoLogic XL/L.

8.4.11 Define, SMS

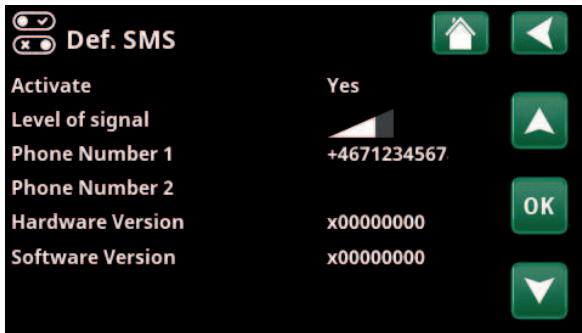

Menu: "Advanced/Define/ SMS".

Activate No (Yes/No)

If "Yes" is selected, the menus below are displayed:

Level of signal

The signal strength of the reception is shown here.

Phone Number 1

The first activated phone number is shown here.

Phone Number 2

The second activated phone number is shown here.

Hardware Version

The hardware version of the SMS accessory is shown here.

Software Version

The software version of the SMS accessory is shown here.

NB: For more information about the SMS function, refer to the "Installation and Maintenance Manual" for CTC SMS.

8.4.12 Define, SmartControl

CTC SmartControl is a separate series of wireless accessories.

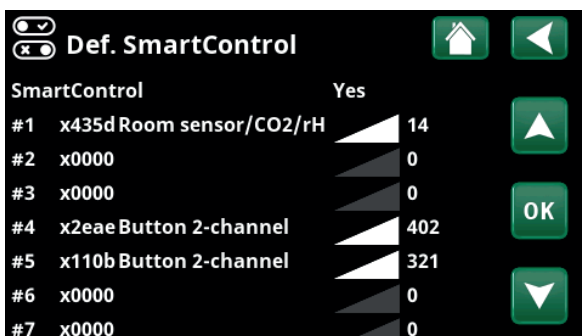

Menu: "Advanced/Define/SmartControl".

SmartControl No (Yes/No)

If "Yes" is selected, CTC SmartControl accessories can be connected to the heating circuit. See the connection procedure in the separate CTC SmartControl accessories manual.

8.4.13 Define, Wireless II

CTC Wireless Room Sensor II is a separate series of wireless accessories.

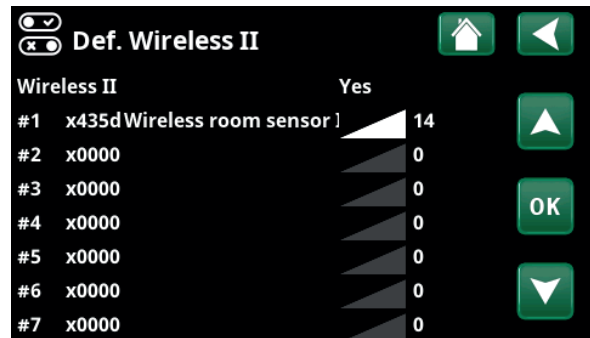

Menu: "Advanced/Define/Wireless II".

Wireless II No (Yes/No)

If "Yes" is selected, CTC Wireless Room Sensor II accessories can be connected to the heating circuit. See the connection procedure in the separate CTC Wireless Room Sensor II accessories manual.

8.4.14 Define, Current sensor

Current sensor No (Yes/No)

Select "Yes" if current sensors are to be connected to the system.

For more information, refer to the "Current Sensors" section in the "Advanced/Settings" chapter.

8.5 Service



! NB: This menu is intended for the installer only.

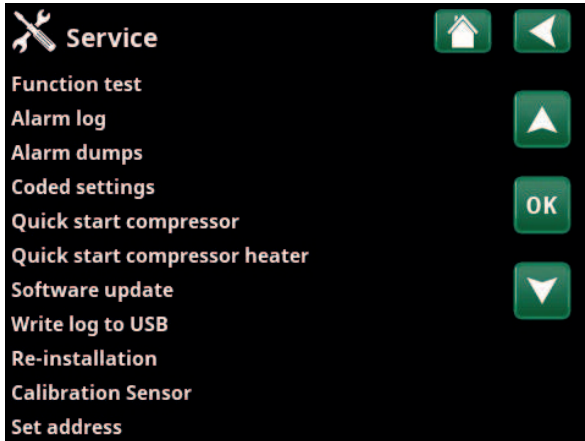

Menu: "Advanced/Service".

8.5.1 Function test

From this menu, the installer can test the connection and function of separate components of the heating circuit. When this menu is activated, all control functions are stopped. The only protection against incorrect operation are the pressure sensors and the immersion heaters overheating protection device. The heat pump returns to normal operation after 10 minutes of inactivity or when exiting the "Function test" menu. When the menu is opened, all automatic functions are stopped and testing can be performed.

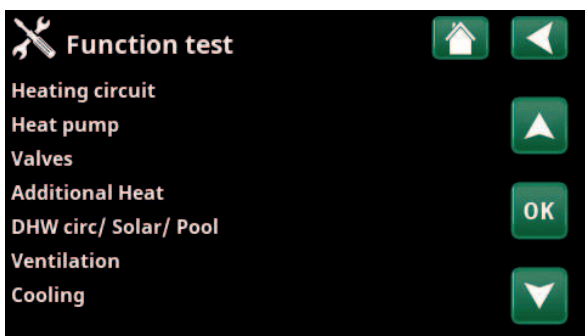

Menu: "Advanced/Service/ Function test".

i When you exit the menu, the heat pump returns to normal operation.

8.5.1.1 Heating circuit*

If several heating circuits have been installed, they will all be displayed here.

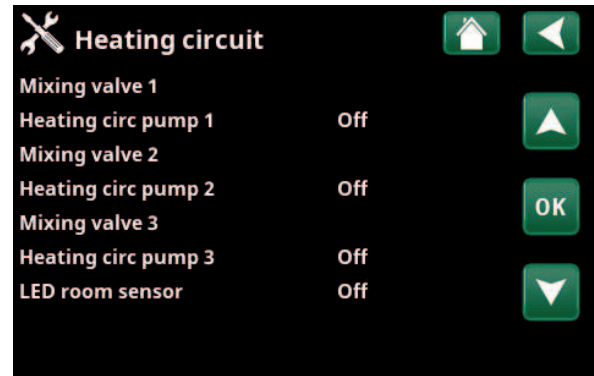

Menu: "Advanced/Service/ Function test/Heating circuit".

Mixing valve (1-)

Opens and closes the respective mixing valve.

Heating circ pump (1-) Off (On/Off)

Starts and stops the respective radiator pump.

LED room sensor Off (On/Off)

The room sensor alarm functions can be controlled from here. When activated, the respective room sensor's red LED comes on steady.

*The number of possible heating circuits or heat pumps that can be connected to the system varies depending on the control system.

8.5.1.2 Heat pump*

Select the heat pump (1-*) to be function tested.

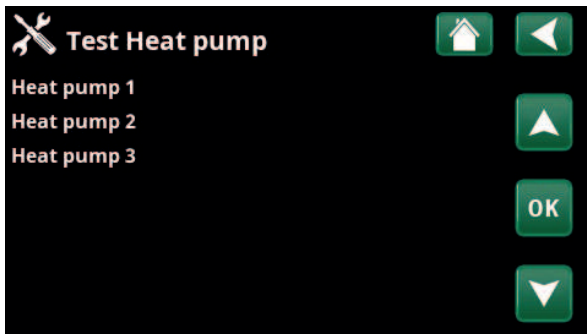

Menu: "Advanced/Service/Function test/Heat pump".

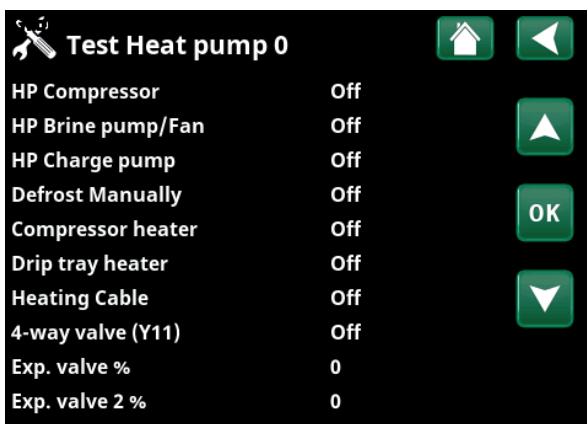

Menu: "Advanced/Service/Function test/Heat pump/Heat pump 1".

HP Compressor Off (On/Off)

When the compressor is being function tested, the brine and charge pump are also operating so that the compressor does not trigger its pressure switches.

HP Brine pump/Fan Off (Off/On)

Function test brine pump or fan (air-to-water HP).

HP Charge pump Off (Off/0...100)

Function test charge pump 0-100%.

Defrost manually Off (Off/On)

When the "Manual defrosting" function is tested, a defrosting cycle will be performed in the air-to-water heat pump. Defrosting cannot be stopped once it has been started and the defrosting programme will be completed.

Compressor heater Off (Off/On)

Function test compressor heater.

Drip tray heater Off (Off/On)

Function test of the condenser tray heater.

Heating cable Off (Off/On)

Function test heating cable.

4-way valve (Y11) Off (Off/On)

Function test 4-way valve (Y11). Fitted to air-to-water HP.

Exp. valve /2 % 0 (0...100)

Function test expansion valve. This menu bar is displayed depending on heat pump model.

8.5.1.3 Valves

The following valves are function tested from this menu:

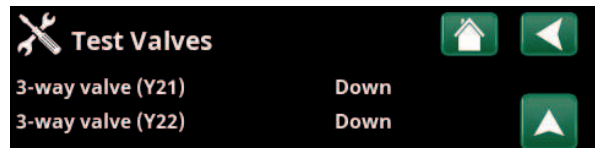

Menu: "Advanced/Service/Function test/Valves".

3-way valve (Y21) Down (Up/Down)
 3-way valve (Y22) Down (Up/Down)
 (Up = DHW; Down = Heating)

8.5.1.4 Additional heat

Here, the output stage of the internal immersion heater (E2) and connected additional heat sources are tested.

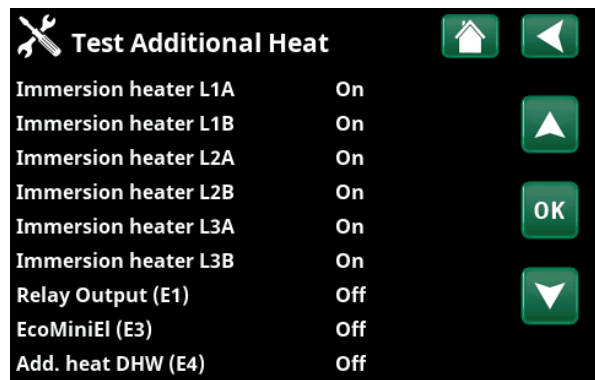

Menu: "Advanced/Service/Function test/Additional heat".

Immersion heater L1A/L1B Off (On/Off)

Immersion heater L2A/L2B Off (On/Off)

Immersion heater L3A/L3B Off (On/Off)

Relay Output (E1) Off (On/Off)

Switches the relay output on and off.

EcoMiniEI (E3) Off (1...3/Off)

Function test 3 steps.

Additional heat DHW (E4) Off (On/Off)

Switches the immersion heater for DHW production on and off.

*The number of possible heating circuits or heat pumps that can be connected to the system varies depending on the control system.

8.5.1.5 DHW circulation/Solar/Pool*

The following pumps/valves are function tested from this menu:

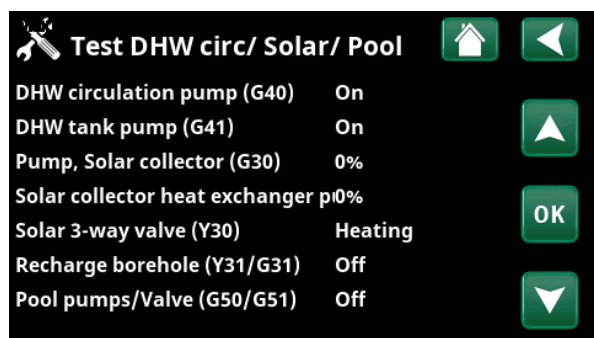

Menu: "Advanced/Service/Function test/ DHW circulation/Solar/Pool".

- DHW circulation pump (G40) On (On/Off)**
Switches the circulation pump on and off.
- DHW tank pump (G41) On (On/Off)**
Switches the circulation pump on and off.
- Pump, Solar collector (G30) 0% (0...100)**
Tests the circulation pump to full speed (rpm).
- Solar heat exchanger pump (G32) 0% (0...100)**
Tests the solar heat exchanger pump up to full speed (rpm).
- Solar 3-way valve (Y30) DHW (DHW/HC)**
Tests the two modes on the valve: flow to DHW tank or buffer tank.
- Recharge borehole (Y31/G31) Off (On/Off)**
Tests the 3-way valve (Y31) and solar heat exchanger pump (G31).
- Pool pumps and valve (G50, G51) Off (On/Off)**
Tests the pool pumps and valve (G50, G51).

8.5.1.6 CTC EcoVent*

- Exhaust fan M40 0% (0...100)**
In this menu, the exhaust fan (M40) is functionally tested up to full speed (100%).

8.5.1.7 Cooling*

The following pumps/valves are function tested from this menu:

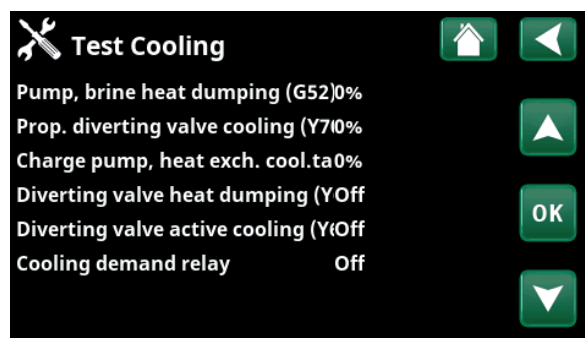

Menu: "Advanced/Service/Function test/Cooling.

- Pump, brine heat dumping (G52) 0% (0...100)**
Tests the pump for heat dumping to the brine up to full speed (rpm).
- Prop. diverting valve cooling (Y70) 0% (0...100)**
Tests the diverting valve for brine up to full opening (rpm).
- Charge pump, heat exch. cooling tank (G53) 0% (0...100)**
Tests the charge pump for exchanger cooling tank up to full speed (rpm).
- Diverting valve heat dumping (Y64) Off (On/Off)**
Switches the diverting valve on and off.
- Diverting valve active cooling (Y61) Off (On/Off)**
Switches the diverting valve on and off.
- Cooling demand relay Off (On/Off)**
Switches the demand relay on and off.

*Applies to CTC EcoLogic XL/L.

8.5.2 Alarm log

In the alarm log, up to 500 alarms can be displayed at the same time.

An alarm which reoccurs within an hour is ignored so as not to fill up the log.

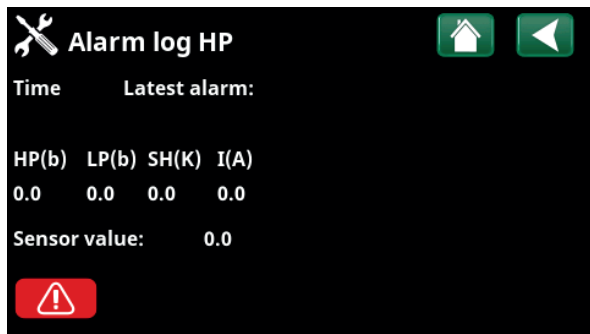

Menu: "Advanced/Service/ Alarm log".

Click an alarm row to see more information about an alarm.

If it is a "sensor alarm", a sensor value will be displayed at the bottom of the page from when the alarm was triggered for further troubleshooting.

For alarms related to the heat pump, values can be displayed from sensors for pressure (HP, LP), temperature (SH=Superheating) and current (I).

! NB: Only an authorised service engineer is allowed to log in to the Factory settings coded option. Severe operational problems and faults may occur affecting the product if values are amended without authorisation. Note that in such cases the warranty terms do not apply.

8.5.3 Alarm dumps

Export the alarms displayed in the alarm log to a USB drive. A dump can consist of one or more alarms as well as specific values before and after the alarm was triggered.



Menu: "Advanced/Service/Alarm dumps".

8.5.4 Coded settings

This menu is intended to set the manufacturer's operational and alarm limits. A 4-digit code must be specified to be able to amend these limits. However, you can also look without any code to see what options feature in the menu.

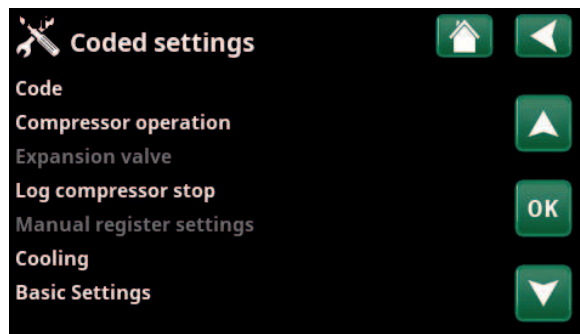

Menu: "Advanced/Service/Coded settings".

8.5.5 Quick start compressor

The delay normally prevents compressor start earlier than 10 mins after compressor stop. The delay is also activated in the event of a power failure, or the first time after production is started. This function speeds up this process.

For "System Types" 1 to 3, the degree minutes loss is set to the value that starts all heat pumps.

8.5.6 Quick start compressor heater

This function starts the compressor preheater, which speeds up the process of getting the compressor ready to start.

Only applies in combination with CTC EcoAir 700M.

8.5.7 Software update

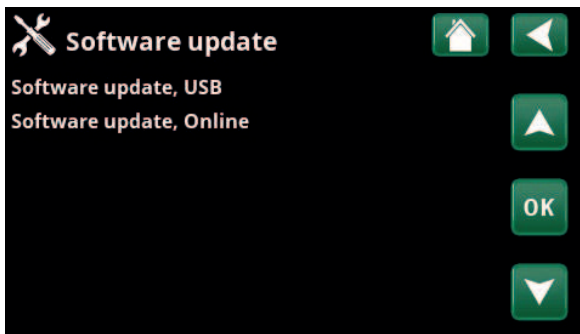

Menu: "Advanced/Service/ Software Update".

The display software can be updated either via USB drive or online. The rows are greyed out until the USB drive is installed or the display is connected to the internet.

Click OK to confirm the upload.

The settings are retained during updating, but the old values are overwritten by any new factory values.

i The product must be registered in myUplink for new software updates to be available for download.

! NB: The power to the product must not be interrupted, under any circumstances, during the update process.

! NB: Turn off the power and always restart the product after software update. Several minutes may pass before the display communicates clearly after restart.

8.5.8 Write log to USB

Intended for service engineers. This function can be used to save logged values to a USB memory stick.

8.5.9 Re-installation

This command relaunches the installation sequence. First, confirm that you want to reinstall to access the installation wizard, refer to the "Installation Guide" and "First Start" chapters.

8.5.10 Calibration Sensor

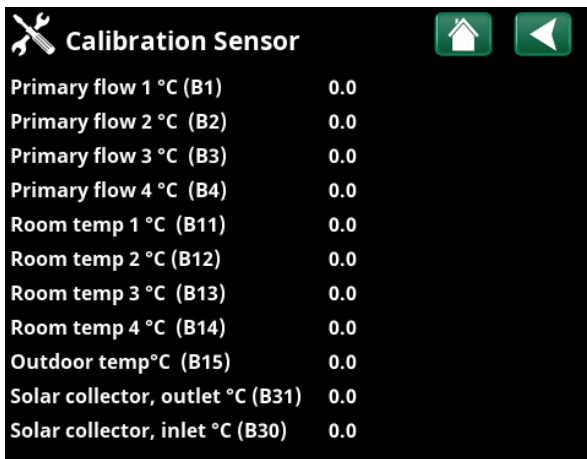

Menu: "Advanced/Service/Calibration Sensor".

Primary flow 1 °C (B1)	0.0 (-3.0...3.0)
Correction of primary flow sensor (B1).	
Primary flow 2 °C (B2)	0.0 (-3.0...3.0)
Correction of primary flow sensor (B2).	
Primary flow 3 °C (B3)	0.0 (-3.0...3.0)
Correction of primary flow sensor (B3).	
Primary flow 4 °C (B4)	0.0 (-3.0...3.0)
Correction of primary flow sensor (B4).	
Room temp 1 °C (B11)	0.0 (-3.0...3.0)
Correction of room sensor (B11).	
Room temp 2 °C (B12)	0.0 (-3.0...3.0)
Correction of room sensor (B12).	
Room temp 3 °C (B13)	0.0 (-3.0...3.0)
Correction of room sensor (B13).	
Room temp 4 °C (B14)	0.0 (-3.0...3.0)
Correction of room sensor (B14).	
Outdoor temp °C (B15)	0.0 (-3.0...3.0)
Correction of outdoor sensor (B15).	
Solar collector, outlet °C (B31)	0.0 (-3.0...3.0)
Correction of temperature sensor on solar collectors for outgoing temperature.	
Solar collector, inlet °C (B30)*	0.0 (-3.0...3.0)
Correction of temperature sensor on solar collectors for incoming temperature.	

8.5.11 Set address

In this menu, heat pumps and expansion boards can be assigned addresses.

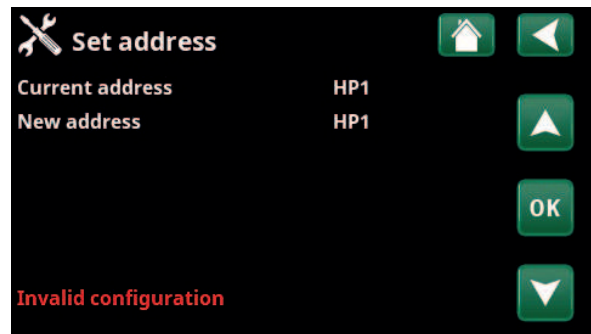

Menu: "Advanced/Service/Set address".

The error message "Invalid Configuration" is displayed if the same heat pump is specified in the "Current address" and "New address" rows, as shown in the menu view on the right.

- Actual address** (HP1...HP10, EXP1, EXP2)
Specify the current address of the heat pump or expansion board.
- New address** (HP1...HP10, EXP1, EXP2)
Specify the address to be assigned to the heat pump or expansion board.

9. Parameter list CTC EcoLogic XL/L/M

	Fact. set.
Heating circuit	
Program Economy	-
Room temp change °C	-2.0
Off delay, min	30
Program Comfort	-
Room temp change °C	2.0
Off delay, min	30
Max primary flow °C	55
Min primary flow °C	Off
Heating, mode	Auto
Heating mode, ext.	On
Schedule, Heating mode	
Heating off, out °C	18
Heating off, time (min)	120
Heating on, time (min)	120
Night reduction down to °C	5
Room temp. reduced, Night red. °C	-2
Room temp. reduced, Holiday	-2
Primary flow reduced, Night red. °C	-3
Primary flow reduced, Holiday	-3
Regulate room temp (min.)	Off
Radiator pump speed	100
Alarm room temp °C	5
SmartGrid Low Price °C	Off
SmartGrid Overcapacity °C	Off
SmartGrid Blocking	Off
Drying period	
Temp °C	25
Drying period (Heating circuit 2-)	Off
Heat pumps	
Start at degree minute	-60
Max primary flow HP diff °C	10
Max primary flow HP Add. heat diff °C	14
Diff between HP	-60
Delay between HP	30
Delay primary flow temp. (sec.)	180
Start at degree minute cooling*	60
Diff between comp. cooling*	60
Prio A/W °C	7
Prio DHW A/W °C	7
SmartGrid Blocking HP	No
Defrost heating temp min m	10
Defrost heating temp max m	10

	Fact. set.
Defrost heating temp min °C	10
Defrost heating temp max °C	-10
Heat pump 1-	
Compressor	Blocked
Stop at outdoor °C	-22
Charge pump %	50
Cold temp limit	0
Max RPS	90
Warm temp limit	20
Max RPS warm temp	50
Ext. noise reduction RPS	50
Schedule, Noise reduction	
Compressor stop at brine °C	-5
Brine pump	Auto
Tariff HP	No
Schedule, Tariff HP	
Passive cooling brine pump on	Yes
Schedule, Silent mode	
Max. main current A	13/16/20**
HP relay failsafe	0
Function HP relay	-
Additional heat	
Additional heat E1	On
Start E1, degree minute	-500
Diff E1, degree minute	-100
Delay add. heat E1	180
Additional heat E2	7
Start E2, degree minute	-500
Diff E2, degree minute	-100
Delay add. heat E2	180
Diff delay E2	60
Additional heat EcoMiniEl	No
Start EcoMiniEl, degree minute	-500
Diff step EcoMiniEl	-50
Delay EcoMiniEl	180
Delay EcoMiniEl step	30
Block additional heat, out	5
Boiler, open mixing valve °C	70
Boiler max °C	Off
Main fuse A	20
Conv. factor current sensor	1
Tariff EL	No

*Displayed if "Active cooling" has been defined.

**The value may vary depending on the heat pump model.

	Fact. set.
Schedule, Tariff EL	
SmartGrid Block. immersion	No
Start at flue gas °C	Off
E1 Charge pump HP1 (G11) %	100
E2 Charge pump HP1 (G11) %	70
E3 Charge pump HP1 (G11) %	70
DHW tank	
Program DHW	Economy/ Normal/ Comfort
- Stop temp HP °C	50/55/58
- Extra DHW stop temp °C	60
Start/stop diff °C	5
Max time DHW (min)	20
Max time heating (min)	40
Additional heat DHW	Auto
Additional heat DHW E1	No
Additional heat DHW E2	3
Add. heat DHW EcoMiniEI	3
Min temp °C	45
Periodic increase DHW, days	14
Periodic increase DHW, °C	65
Periodic increase DHW, time (min)	Off
Max temp diff end DHW °C	3
Start/stop diff HP2 °C	3
Start/stop diff °C	3
Stop DHW diff max °C	3
Run time DHW circ. (min)	4
Period time DHW circ. (min.)	15
Diff start ext. DHW tank	5
Schedule, DHW circulation	
SmartGrid Blocking °C	Off
SmartGrid Low Price °C	Off
SmartGrid Overcapacity °C	Off
SmartGrid Overcapacity block HP	No
Time Extra DHW Remote Control	0.0
Buffer tank	
Heating curve	
Tank max °C	55
Tank min °C	30
Diff tank vs. primary °C	0
Start/Stop diff tank °C	5
Setpoint schedule °C	50
Schedule, Buffer tank	
SmartGrid Low Price °C	Off
SmartGrid Overcapacity °C	Off
Allow overtemp during cooling	No

	Fact. set.
Solar collectors	
dT max solar °C	7
dT min solar °C	3
Min speed pump %	30
Max boiler °C	85
Max DHW tank °C	85
Max buffer tank °C	85
Max temp brine °C	18
dT max borehole °C	60
dT min borehole °C	30
Solar test tank (min)	4
Test frequency (min)	30
Winter mode	No
Flow l/mln	6.0
Protection collector	
Emergency cooling	Yes
Max temp °C	120
Re-cooling	No
Re-cooling to temp °C	70
Freeze protection	No
Freeze protection °C	-25
Re-cooling stop delay (min)	10
Pool	
Pool	Blocked
Pool temp °C	22
Pool diff °C	1.0
Pool priority	Low
SmartGrid Blocking °C	Off
SmartGrid Low Price °C	Off
SmartGrid Overcapacity °C	Off
Block pool	No
Schedule, Block pool	
Cooling	
Room temp cooling °C	25.0
Cooling permit. from outdoor T*	Off
Active delay*	10
Heating off delay*	10
Start delay*	180
Diff. delay calc.*	Off
Cooling curve	
Max primary flow °C	20
Min primary flow °C	18
Min Flow temp Cooling °C	18
Max. diff. room temp. cooling °C	5
Primary flow diff at outdoor +20 °C*	2
Primary flow diff at outdoor +40 °C*	2

*Displayed if "Active cooling" has been defined.

Fact. set.	
Tank max °C	30
Tank min °C	5
Heat exchanger diff. °C	10
SmartGrid Low Price °C	Off
SmartGrid Overcapacity °C	Off
Ext. block cooling	No
Schedule, Blocking cooling	
Max temp brine °C	18
Start HP delay	30
Communication	
Ethernet	-
BMS	-
myUplink	-
El. prices	
Power limitation	
Mode	Blocking
Limit value (kW)	4.2
Offset (kW)	0.2
Allow power peak	Yes
Schedule	

10. Operation and Maintenance

When the installer has installed your new heat pump, you should check along with the installer that the system is in perfect operating condition. Let the installer show you where the switches, controls and fuses are so that you know how the system works and how it should be maintained. Bleed the radiators after around three days of operation and top up with water if required.

The heat pump works completely automatically. The control system turns on additional heat when needed, adapts to wood burning when this occurs, automatically switches to summer mode, etc.

Room Sensor

A room sensor, which should always be fitted (up to four room sensors can be connected), ensures that the temperature in the room is always suitable and stable.

For the sensor to provide the correct signals to the control unit, radiator thermostats should always be fully open in the area where the room sensor is located.

When adjusting the system, always do so with all radiator thermostats fully open. The thermostats can be individually adjusted after a few days in the various rooms.

You can select operation without room sensors by selecting "No" in the "Advanced/Define/Heating Circuit/Heating Circuit 1-3/Room Sensors" menu. This can be done if it is difficult to find a location for the room sensor, if there are several flats, if the floor heating circuit has separate room sensors, or when using an fire place or open stove.

The alarm LED on the room sensor still functions as normal. If you use the fire or open stove only occasionally, the firing process can affect the room sensor and reduce the temperature supplied to the radiators. It can then get cold in the rooms in other parts of the house. The room sensor can be temporarily deselected during the firing process. The heat pump then provides heating to the radiators using the set heating curve, see the "House Heating Curve" chapter. The radiator thermostats reduce the heating supplied to the section of the house where a fire is burning.

"Summer Cellar Heat"

You will often want some background heating in basements/recreation rooms/bathrooms in the summer months, to avoid raw, damp air. The heat pump takes care of this by setting the minimum permitted primary flow temperature to a suitable temperature (15-65 °C). Refer to the "Advanced/Settings/Heating Circuit/Min Primary Flow °C" menu.

This means that the temperature supplied to the radiators will not fall below a selected temperature, for example +35 °C. For this to work, the rest of the house must have functional radiator thermostats or shut-off valves. These shut off the heating in the rest of the house.

The function can also be used for floor heating in the bathroom to ensure warm floors during the summer.

Night reduction

With night reduction you have the option of automatically varying the temperature in the house throughout the day, every day of the week. More information can be found in the chapter "Display settings/Night reduction".

11. Troubleshooting

The heat pump is designed to provide reliable operation and high levels of comfort, and to have a long service life. Various tips are given below which may be helpful and guide you in the event of an operational malfunction. If a fault occurs, you should always contact the installer who installed your unit. If the installer believes the malfunction is due to a materials or design fault, then they will contact us to check and rectify the issue. Always provide the product's serial number.

DHW

Many people want to gain maximum benefit from the heat pump's low operating costs. The control system is equipped with three comfort levels for DHW. We recommend starting at the lowest level and if there is not enough hot water, increase it to the next level. We also recommend that you operate a regular DHW pattern.

Heating circuit

A room sensor, which should be fitted when possible, ensures that the temperature in the room is always suitable and stable. For the sensor to provide the correct signals to the control unit, radiator thermostats should always be fully open in the area where the room sensor is located.

i Avoid placing the room sensor close to the stairway due to the uneven air circulation.

A correctly operating heating circuit is of significant importance to the heat pump's operation and affects energy savings.

When adjusting the system, always do so with all radiator thermostats fully open. The thermostats can be individually adjusted after a few days in the other rooms.

i If you do not have radiator thermostats on the upper floor, you may need to install them.

If you do not achieve the set room temperature, check:

- That the heating circuit is correctly adjusted and is functioning normally. That radiator thermostats are open and the radiators are equally warm all over. Touch the entire radiator surface. Bleed the radiators. In order for the heat pump to run economically, the heating circuit must function well in order to provide good savings.
- That the heat pump is operating and no error messages are displayed.
- That there is sufficient electrical power available. Increase this if necessary. Also check that the electric power output is not limited due to excessively high electricity loads in the house.
- that the product is not set to the "Max allowed primary flow temperature" mode with a too low set value.
- That "Primary flow temperature at -15°C outdoor temperature" is set sufficiently high. Increase if necessary. More can be read about this in the chapter on the "House heating curve". However, always check the other points first.
- That the temperature reduction is set correctly. See Settings/Heating circuit.
- that the mixing valve is not in the manual position.

If the heat is not even, check:

- That the placement of the room sensors is appropriate for the house.
- That the radiator thermostats don't interfere with the room sensor.
- That no other heat sources/cold sources interfere with the room sensor.
- that the mixing valve is not in the manual position.

Ground loop

Faults can occur in the cooling unit if the ground loop has not been installed correctly, if it has not been bled sufficiently, if it contains too little antifreeze or is not designed to an adequate size. Poor or insufficient circulation can result in the heat pump triggering an alarm in the case of low evaporation. If the temperature difference between the ingoing and outgoing temperature is too large, the product triggers an alarm and "Low brine flow" is displayed. The probable cause is that there is still air in the brine circuit. Bleed thoroughly, which may in some cases take up to a day. Also check the ground loop. See also the section entitled "Connecting the brine system".

Check:

- that the brine pump speed value is not set too low. Try to increase this if a problem arises.

Reset the "Low evaporation" alarm on the display. Where a malfunction repeatedly occurs, call in a technician to investigate and rectify the fault.

If the text "Low brine temp" is displayed, the ground loop may not be large enough or there may be a fault with the sensor. Check the brine circuit temperature in the "Current operation data" menu. If the incoming temperature falls below -5 °C during operation, call in a technician to inspect the brine circuit.

Motor protection

The heat pump constantly monitors the compressor's operating current and an alarm is triggered if the compressor is using an unusually high current. When a fault occurs, the message "Motor protect high current" is displayed.

The cause of the fault may be as follows:

- Phase failure or mains interruption. Check the fuses, which are the most common cause.
- Compressor overload. Call out a service engineer.
- Faulty compressor. Call out a service engineer.
- Circulation too poor between the cooling circuit and cylinder. Check the heat medium pump (charge pump).
- Abnormally high temperature in the brine circuit. Call out a service engineer.

11.1 Information messages

Information messages are displayed when appropriate and are intended to inform users about various operational situations.



[I013] Start delay

The compressor is not allowed to start too quickly when it has stopped. The delay is usually at least 10 minutes.

[I002] HC1 Heating off

[I005] HC2 Heating off

[I006] HC3 Heating off

[I007] HC4 Heating off

Shows for each heating circuit that the product is operating in summer mode when only DHW is required, not heating.

[I011] Round circulation

Indicates that round circulation is active. Round circulation is a device which an electricity supplier can fit with the aim of disconnecting high current draw equipment for a short period of time. The compressor and electrical output are blocked when round circulation is active.

[I008] Tariff HP off

Indicates that Tariff has switched off the heat pump.

[I010] Tariff EL Off

Shows that tariff has switched off the immersion heater elements.

[I009] Compressor blocked

The compressor is set to be shut down, e.g. before drilling or digging has been carried out for the collector coils. The product comes with the compressor switched off. This option is selected in the "Advanced/Settings/Heat Pump" menu.

[I021] HC1 Heating mode, remote ctrl

[I022] HC2 Heating mode, remote ctrl

[I023] HC3 Heating mode, remote ctrl

[I024] HC4 Heating mode, remote ctrl

The remote control affects whether the heating is to be on or off. If the heating is switched off, "Heating off, heating circuit 1/2/3" is also displayed.

[I017] SmartGrid: Blocking

[I019] SmartGrid: Low price

[I018] SmartGrid: Overcapacity

The product is externally affected by "SmartGrid". See also "Define/Remote control/SmartGrid".

[I030] Driver block undervoltage

The heat pump has stopped due to insufficient mains voltage. The product will attempt to restart.

[I031] Driver block alarm

The heat pump has stopped due to driver failure; for example, voltage or excessive temperature. The product will attempt to restart.

[I050] Power limitation

Indicates that power limitation is activated.

11.2 Alarm messages



If a fault occurs with e.g. a sensor, an alarm is triggered. A message appears on the display with information about the fault. In the event of an alarm, the LEDs on the display and room sensor also flash.

You reset the alarm by pressing the “Reset alarm” button on the display. If several alarms are triggered, they are displayed one after the other. A persisting fault must first be rectified before it can be reset. Some alarms are reset automatically if the fault ceases.

Alarm messages	Description																		
[E055] Wrong phase order	The product’s compressor motor must rotate in the right direction. The product checks that the phases are connected correctly; otherwise, an alarm is triggered. This will require changing two of the phases into the product. The power supply to the system must be shut off when rectifying this fault. This fault generally only occurs during installation.																		
[Exxx] sensor	An alarm is displayed if a fault occurs with a sensor that is not connected or has short-circuited. If this sensor is significant to the system’s operation, the compressor stops. This requires the alarm to be reset manually after the fault has been rectified.																		
	<table border="0"> <tr> <td>[E002] Sensor, external boiler (B9)</td> <td>[E031] Primary flow sensor 1 (B1)</td> </tr> <tr> <td>[E007] Sensor, buffer tank (B6)</td> <td>[E032] Primary flow sensor 2 (B2)</td> </tr> <tr> <td>[E012] Sensor, DHW tank (B5)</td> <td>[E033] Primary flow sensor 3 (B3)</td> </tr> <tr> <td>[E015] Sensor, external boiler out (B10)</td> <td>[E034] Primary flow sensor 4* (B4)</td> </tr> <tr> <td>[E016] Sensor, solar collector In* (B30)</td> <td>[E074] Room sensor 1 (B11)</td> </tr> <tr> <td>[E017] Sensor, solar collector Out* (B31)</td> <td>[E075] Room sensor 2 (B12)</td> </tr> <tr> <td>[E018] Sensor, external DHW tank* (B43)</td> <td>[E076] Room sensor 3* (B13)</td> </tr> <tr> <td>[E019] Sensor, pool* (B50)</td> <td>[E077] Room sensor 4* (B14)</td> </tr> <tr> <td>[E030] Outdoor sensor (B15)</td> <td></td> </tr> </table>	[E002] Sensor, external boiler (B9)	[E031] Primary flow sensor 1 (B1)	[E007] Sensor, buffer tank (B6)	[E032] Primary flow sensor 2 (B2)	[E012] Sensor, DHW tank (B5)	[E033] Primary flow sensor 3 (B3)	[E015] Sensor, external boiler out (B10)	[E034] Primary flow sensor 4* (B4)	[E016] Sensor, solar collector In* (B30)	[E074] Room sensor 1 (B11)	[E017] Sensor, solar collector Out* (B31)	[E075] Room sensor 2 (B12)	[E018] Sensor, external DHW tank* (B43)	[E076] Room sensor 3* (B13)	[E019] Sensor, pool* (B50)	[E077] Room sensor 4* (B14)	[E030] Outdoor sensor (B15)	
[E002] Sensor, external boiler (B9)	[E031] Primary flow sensor 1 (B1)																		
[E007] Sensor, buffer tank (B6)	[E032] Primary flow sensor 2 (B2)																		
[E012] Sensor, DHW tank (B5)	[E033] Primary flow sensor 3 (B3)																		
[E015] Sensor, external boiler out (B10)	[E034] Primary flow sensor 4* (B4)																		
[E016] Sensor, solar collector In* (B30)	[E074] Room sensor 1 (B11)																		
[E017] Sensor, solar collector Out* (B31)	[E075] Room sensor 2 (B12)																		
[E018] Sensor, external DHW tank* (B43)	[E076] Room sensor 3* (B13)																		
[E019] Sensor, pool* (B50)	[E077] Room sensor 4* (B14)																		
[E030] Outdoor sensor (B15)																			
	and for heat pumps HP1-HP10:																		
	<table border="0"> <tr> <td>[E003] Sensor, brine in</td> <td>[E036] Sensor, high pressure</td> </tr> <tr> <td>[E005] Sensor, brine out</td> <td>[E037] Sensor, discharge gas</td> </tr> <tr> <td>[E028] Sensor, HPin</td> <td>[E043] Sensor, low pressure</td> </tr> <tr> <td>[E029] Sensor, HPout</td> <td>[E080] Sensor, suction gas</td> </tr> <tr> <td></td> <td>[E160] Sensor, suction gas</td> </tr> </table>	[E003] Sensor, brine in	[E036] Sensor, high pressure	[E005] Sensor, brine out	[E037] Sensor, discharge gas	[E028] Sensor, HPin	[E043] Sensor, low pressure	[E029] Sensor, HPout	[E080] Sensor, suction gas		[E160] Sensor, suction gas								
[E003] Sensor, brine in	[E036] Sensor, high pressure																		
[E005] Sensor, brine out	[E037] Sensor, discharge gas																		
[E028] Sensor, HPin	[E043] Sensor, low pressure																		
[E029] Sensor, HPout	[E080] Sensor, suction gas																		
	[E160] Sensor, suction gas																		
[E057] Motor protect high curr.	High current into the compressor has been detected. Press reset and check whether the alarm recurs. If the fault recurs, contact your installer.																		
[E058] Motor protect low curr.	Low current into the compressor has been detected. Press reset and check whether the alarm recurs. If the fault recurs, contact your installer.																		
[E035] High pressure switch	The refrigerant’s high pressure switch has been triggered. Press reset and check whether the alarm recurs. If the fault recurs, contact your installer.																		
[E041] Low brine temp	Incoming brine temperatures from bore hole/ground loop are too low. Press reset and check whether the alarm recurs. If the fault recurs, contact your installer to check the dimensions of the cold side.																		

Alarm messages	Description
[E040] Low brine flow	Low brine flow is often caused by air in the collector system, especially immediately following installation. Collectors which are too long can also be a cause. Check also that the brine pump is set to speed 3. Press reset and check whether the alarm recurs. Also check the brine filter that has been installed. If the fault recurs, contact your installer.
[E063] Comm. error relay board	This message is displayed when the display board (A1) cannot communicate with the relay board. (A2)
[E027] Communication error HP	This message is displayed when the display board (A1) cannot communicate with the HP control board (A5).
[E056] Comm. error motor protection	This message is displayed when the HP control board (A5) cannot communicate with the motor protection. (A4)
[E044] Stop, high compr temp	This message appears when the compressor temperature is high. Press reset and check whether the alarm recurs. If the fault recurs, contact your installer.
[E045] Stop, low evaporation	This message appears when the evaporation temperature is low. Press reset and check whether the alarm recurs. If the fault recurs, contact your installer.
[E046] Stop, high evaporation	This message appears when the evaporation temperature is high. Press reset and check whether the alarm recurs. If the fault recurs, contact your installer.
[E047] Stop, low suction gas exp. valve	This message appears when the suction gas temperature is low. Press reset and check whether the alarm recurs. If the fault recurs, contact your installer.
[E048] Stop, low evaporation exp. valve	This message appears when the expansion valve's evaporation temperature is low. Press reset and check whether the alarm recurs. If the fault recurs, contact your installer.
[E049] Stop, high evaporation exp. valve	This message appears when the expansion valve's evaporation temperature is high. Press reset and check whether the alarm recurs. If the fault recurs, contact your installer.
[E050] Stop, low superheating exp. valve	This message appears when the expansion valve's superheat temperature is low. Press reset and check whether the alarm recurs. If the fault recurs, contact your installer.
[E013] EVO off	This message appears when there is a fault with the expansion valve control.
[E052] Phase 1 missing [E053] Phase 2 missing [E054] Phase 3 missing	This message appears in the event of a phase failure.
[E010] Compressor type?	This message appears if no information about the compressor type is available.
[E026] Heat pump	This message appears if the heat pump is in alarm mode.
[E001] Risk of freezing	Alarm indicating that the temperature of the outgoing water from the heat pump (HP out) is too low for defrosting. The water volume in the system may be too low. The flow may be too low. (Applies to CTC EcoAir)
[E163] Defrost max time duration	The heat pump has not had time to complete defrosting within the maximum time. Make sure that any ice on the evaporator has disappeared.
[E087] Driver	Press reset and check whether the alarm recurs.
[E088] Driver: 1 - [E109] Driver: 29 Driver fault.	If the fault recurs, contact your installer and tell them the error code number where applicable.
[E117] Driver: Offline	Communication error. The junction box and driver of the heat pump are not communicating.

11.3 Critical alarms - Risk of freezing



[E135] Risk of freezing (after four alarms, a new alarm is displayed [E218])

[E211] Risk of freezing low flow (after four alarms, a new alarm is displayed [E219])

[E216] HP flow temp diff (after four alarms, a new alarm is displayed [E220])

[E217] HP Charge pump flow (after four alarms, a new alarm is displayed [E221])

If a critical alarm is shown on the display, take the action described below. Confirm the alarm by entering code 4005 in the display menu "Advanced/Service/Coded settings/Code".

Please note: The critical alarms [E135], [E211], [E216] and [E217] can be acknowledged three times by entering code 4005. **After four alarms, the heat pump is blocked;** in this case, contact the installer. After one year of operation without any alarms, the critical alarms are reset.

[E135] Risk of freezing

Applies to all air/water heat pumps.

Alarm conditions

If the temperature of the water exiting the heat pump (HP out) is lower than 15 °C during a defrost period or if there is more than 15 °C difference between HP in and HP out for more than 20 seconds.

Possible cause

- The circuit temperature and/or flow rate is too low.
- If the sensors (HP in and HP out) do not display the correct value, alarm [E135] can be generated. Check the temperatures using an external thermometer.

Action

- Ensure that the return flow of the heating circuit is at a minimum of 25°C during a defrost period. In the event of low temperature, contact the installer.
- Supplement with a volume tank.
- Check the circulation pump, dirt filter, pipe system and pipe size to ensure flow requirements are met.
- Check the sensors (HP in and HP out) and replace as required.

[E211] Risk of freezing low flow

Applies to CTC EcoAir 600M/700M/C100 with the "Flow Sensor" accessory installed.

Alarm conditions

The flow is less than 10 l/min (CTC EcoAir 610M/614M/708M/712M) or 15 l/min (CTC EcoAir 622M/720M) for more than 30 seconds during a defrost period.

Possible cause

- The circuit temperature and/or flow rate is too low.

Action

- Check the circulation pump, dirt filter, pipe system, pipe size and flow sensor to ensure flow requirements are met.

[E216] HP flow temp diff

Applies to CTC EcoAir 600M/700M/C100.

Alarm conditions

The difference between HP in and HP out exceeds 12 °C in heat operation for more than 15 minutes.

Possible cause

- The circuit temperature and/or flow rate is too low.

Action

- Check the dirt filter, pipe system and speed settings of the circulation pump to ensure flow requirements are met.
- Check the sensors (HP in and HP out) and replace as required.

[E217] HP Charge pump flow

Applies to CTC EcoAir 400.

Alarm conditions

The charge pump speed exceeds 70% during heat operation for more than 30 minutes.

Possible cause

- The circuit temperature and/or flow rate is too low.

Action

- Check the dirt filter, pipe system and speed settings of the circulation pump to ensure flow requirements are met.

Critical alarms during cooling operation

If the critical alarms appear during cooling operation, it is an indication that the base flow is set too low. Remedy by checking and adjusting the base flow.

- If the sound of the circulation pump is perceived as disturbing during constant running up and down, the basic flow rate should be set higher.

12. Pipe installation

The installation must be carried out in accordance with the applicable standards. Apply all the installation settings based on the description in the chapter on "First start".

This chapter shows the fundamental connections of the heat pump(s) and additional heat to the property's heating and DHW system for the six different CTC EcoLogic system solutions. All CTC EcoLogic systems include solar energy; system types 4, 5 and 6 also include heating of the pool. See also the "Electrical installation" chapter.

12.1 System type 1*

CTC EcoLogic system type 1 is designed for connecting the heating circuit to an existing boiler using a mixing valve. The control system starts the boiler only as required, as the mixing valve mixes in the additional heat. The DHW is preheated in the boiler and then heated up in a separate DHW heater.

A flue gas sensor may be fitted to the boiler. Solar energy can be connected to the boiler using a 3-way valve or diverted to recharge the borehole/ground. Cooling can easily be connected to the borehole/ground source heating circuit.

- * CTC EcoLogic M system type 1, does not include the following subsystems and their associated pumps, valves and sensors:
- Heat pumps 3 to 10
 - Heating circuits 3 and 4
 - Cooling
 - Recharging borehole
 - Solar energy
 - DHW circulation

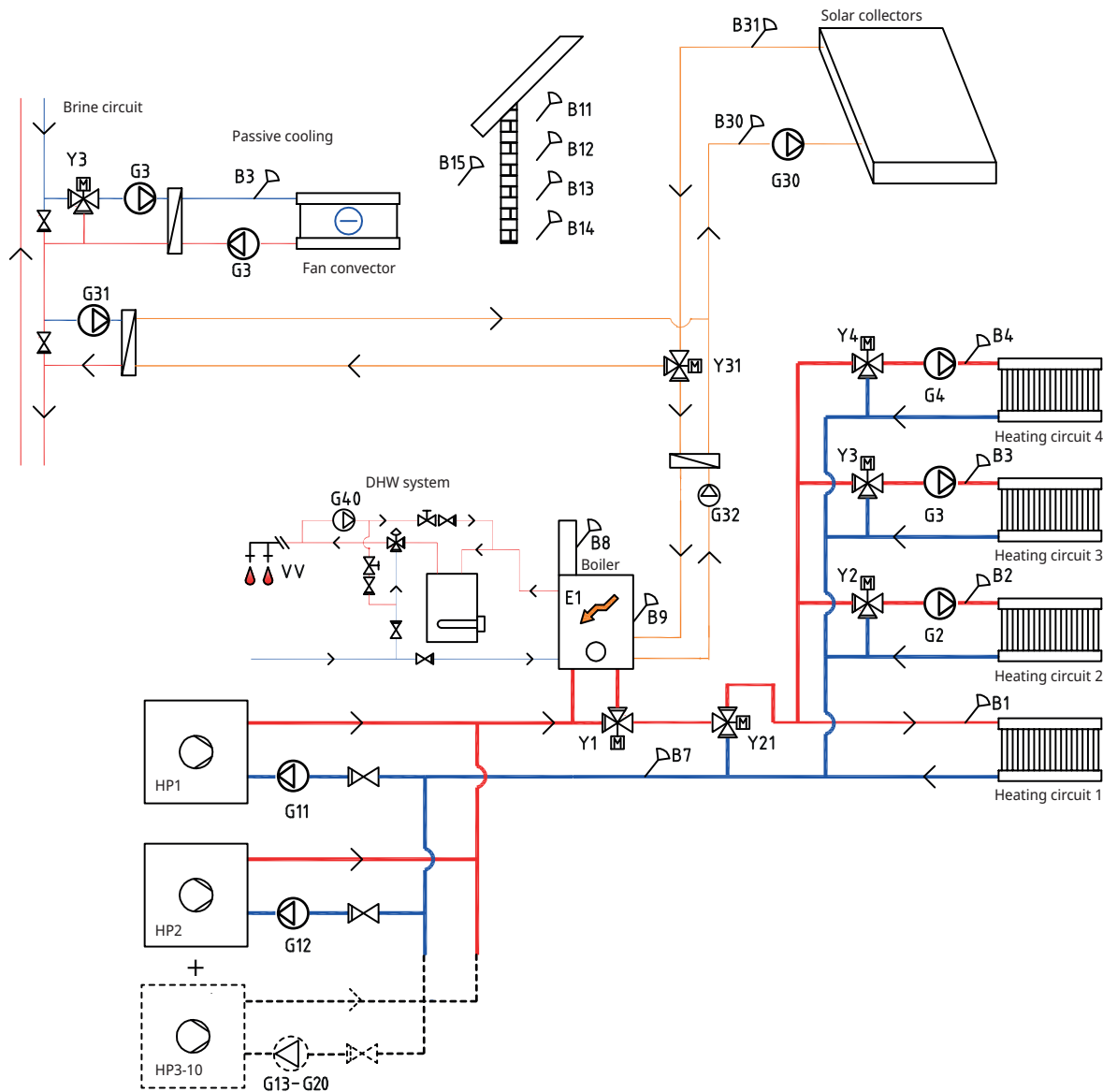

12.1.3 System type 1 - Heating circuit

CTC EcoLogic can be connected to four different heating circuits, each with separate room sensors.

The outdoor sensor (B15) must be fitted to the outer wall of the house, protected from direct sunlight. It is connected using a 2-core cable (min 0.5 mm²).

The room sensors (B11 to B14) must be fitted in an open space in the property where a representative temperature is expected. They are connected using a 3-core cable (min 0.5 mm²).

The primary flow sensors (B1 to B4) must be placed on the primary flow of the respective heating circuit.

Return sensor (B7) is placed on the return flow from the heating circuit.

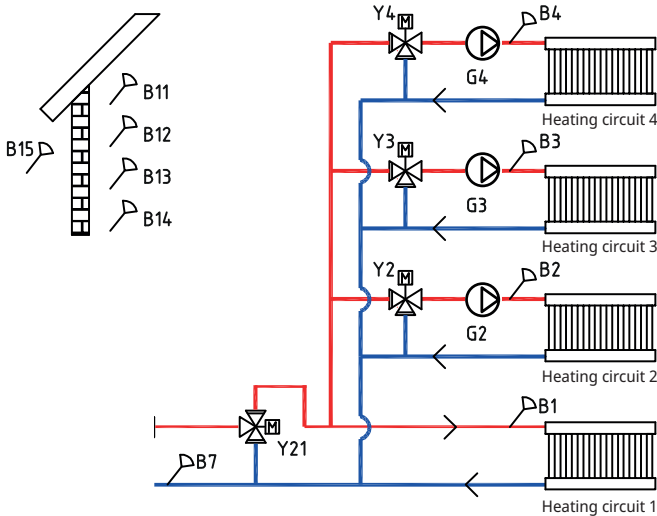

12.1.1 System type 1 - Heat pumps

Up to 10 heat pumps (HP1 to HP10) can be fitted together with their respective charge pumps (G11 to G20).

Charge pumps 1 and 2 (G11 and G12) can be controlled from CTC EcoLogic, while charge pumps G13 to G20 are controlled from their respective heat pumps.

The heat pumps are powered separately, not through CTC EcoLogic.

For more information, refer to the Installation and Maintenance instructions of the respective heat pump.

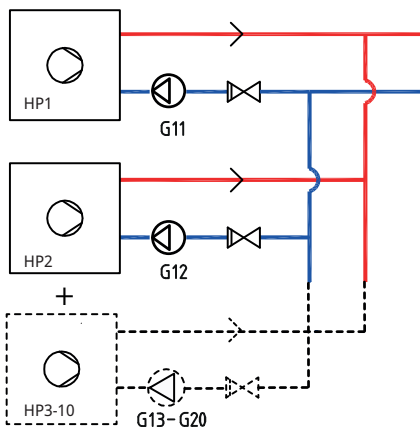

12.1.2 System type 1 - DHW

The DHW is preheated in the boiler by the heat pump and then heated up in a separate hot water boiler. DHW circulation is obtained from the pump (G40). Fresh DHW from the DHW heater is mixed in by the mixing valve and chilled water released down into the tank before once more being heated up. The non-return valves are necessary to ensure that circulation proceeds as intended. Control valves allow the desired flow of the circuit to be adjusted.

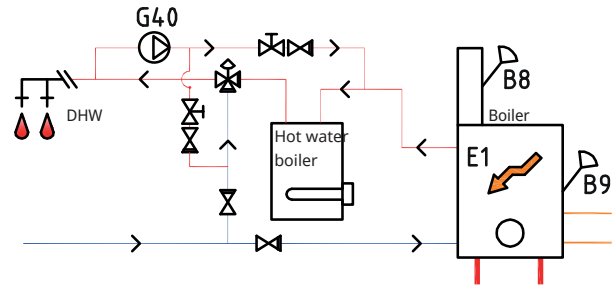

12.1.4 System type 1 - Additional heat (Wood boiler)

The existing boiler is connected to the heating circuit via a mixing valve (Y1).

When wood burning is taking place, the sensor (B8) measures the flue gas temperature and signals to the control system that wood is being lit.

The sensor (B9) should be fitted so that the boiler temperature is measured.

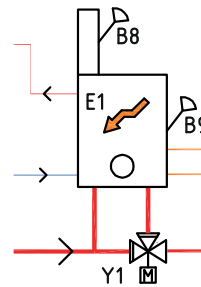

12.1.5 System type 1 - Passive cooling

If the passive cooling function is defined, mixing valve Y3, charge pump G3 and sensor B3 should be used for the cooling installation (not heating circuit 3). For details on how to connect, see the Installation and Maintenance instructions for the passive cooling installation.

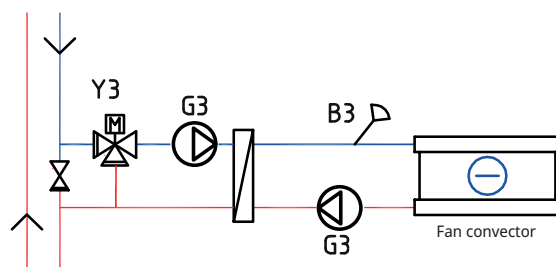

12.1.6 System type 1 - Solar heating

Solar collectors can be connected to the boiler using a 3-way valve (Y31), or to a ground heating coil in order to recharge the borehole/ground.

The speed-controlled pump (G30) and sensors B30 and B31 are fitted next to the solar collectors.

For recharging the borehole/ground, a 3-way valve (Y31), heat exchanger, charge pump (G31) and non-return valve are connected.

The charge pump for recharging the borehole (G31) ensures there is enough flow through the heat exchanger.

The speed-controlled pump (G32) and a heat exchanger are fitted for charging the DHW.

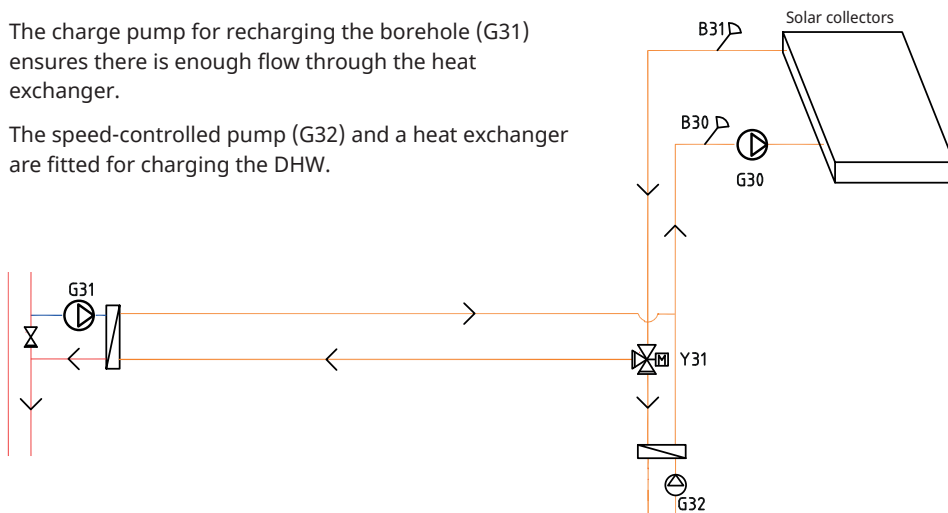

12.2 System types 2 and 3*

The configuration of system types 2 and 3 differ in terms of the location of the additional heat source.

System type 2

In system type 2, the additional heat is located before the DHW system, while in system type 3 it is located after the DHW system.

Heat pumps HP1 and HP2 can be connected using 3-way valves that direct the flow either to the DHW system or the heating circuit. If more heat pumps are installed, these should be connected to the heating circuit.

When connecting the buffer tank, the mixing valve (Y4) is used to connect the tank to the system (not to heating circuit 4).

Solar energy can be connected either to the DHW tank or to the buffer tank using 3-way valves. The solar energy can also be used to recharge the borehole/ground.

Cooling can easily be connected to the borehole/ground source heating circuit.

* CTC EcoLogic M system types 2 and 3 do not include the following subsystems and associated pumps, valves and sensors:

- Heat pumps 3 to 10
- Heating circuits 3 and 4
- Cooling
- Recharging borehole
- Solar energy
- DHW circulation
- External DHW tank
- Buffer tank

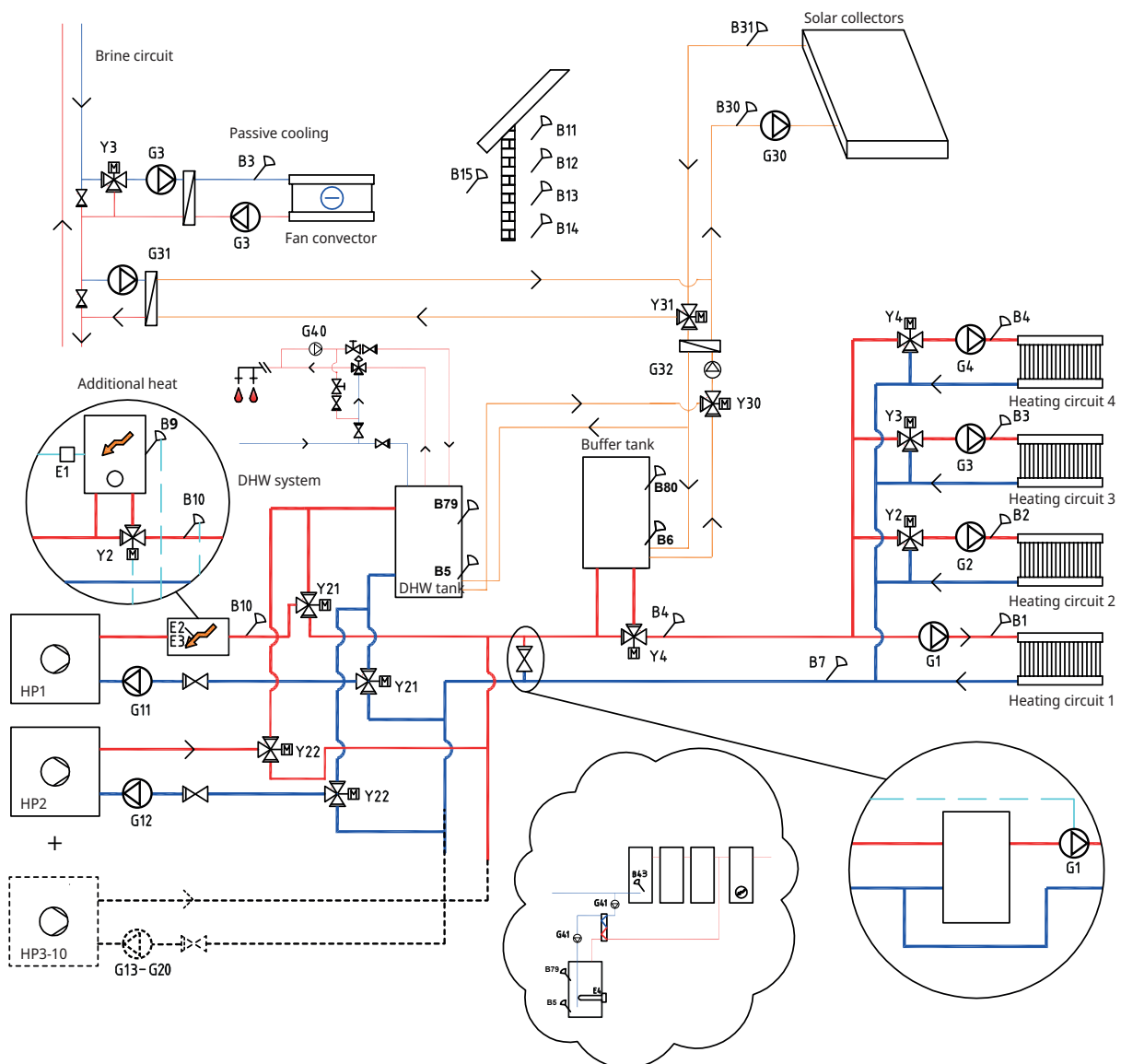

System type 3

In system type 3, the additional heat is located after the DHW system, while in system type 2 it is located before the DHW system. In system type 3 an immersion heater is installed in the DHW tank instead.

When connecting the buffer tank, the mixing valve (Y4) is used to connect the tank to the system (not to heating circuit 4).

Heat pumps 1 and 2 can be connected using 3-way valves that direct the flow either to the DHW system or the heating circuit. The other heat pumps are connected to the heating circuit.

Solar heating can be connected either to the DHW tank or to a buffer tank using 3-way valves, or to a ground heating coil.

Cooling can easily be connected to the borehole/ground source heating circuit.

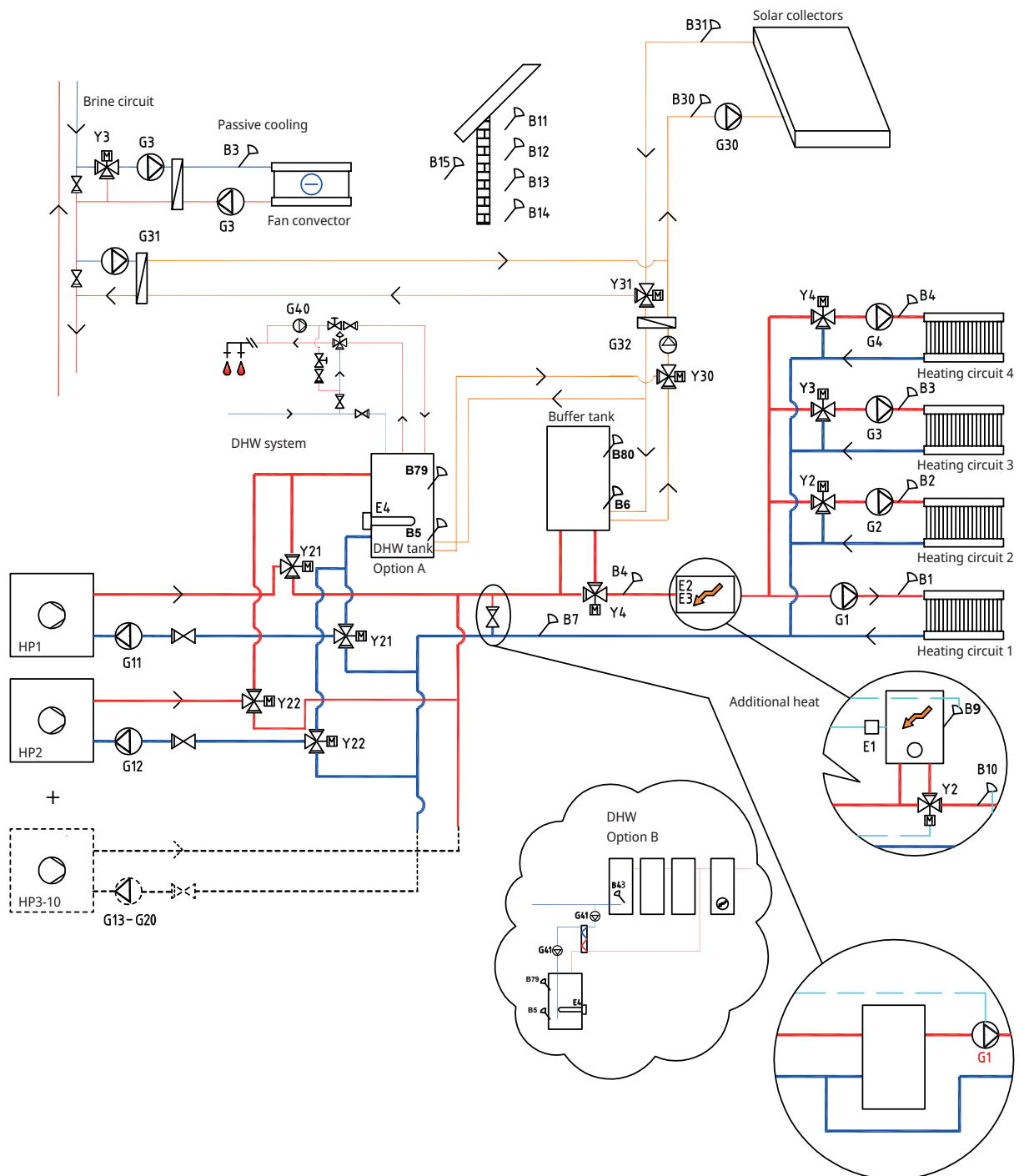

12.2.1 System types 2 and 3 - Heating circuit

CTC EcoLogic can be connected to four different heating circuits, each with separate room sensors. Heating circuits 2, 3 and 4 are connected via mixing valves (Y2, Y3 and Y4). If additional heat (E1) is defined, the mixing valve (Y2) should be used to connect additional heat to the system (not to heating circuit 2).

The outdoor sensor (B15) must be fitted to the outer wall of the house, protected from direct sunlight. It is connected using a 2-core cable (min 0.5 mm²).

The room sensors (B11 to B14) must be fitted in an open space in the property where a representative temperature is expected. They are connected using a 3-core cable (min 0.5 mm²).

The primary flow sensors (B1 to B4) must be placed on the primary flow of the respective heating circuit.

Return sensor (B7) is placed on the return flow from the heating circuit.

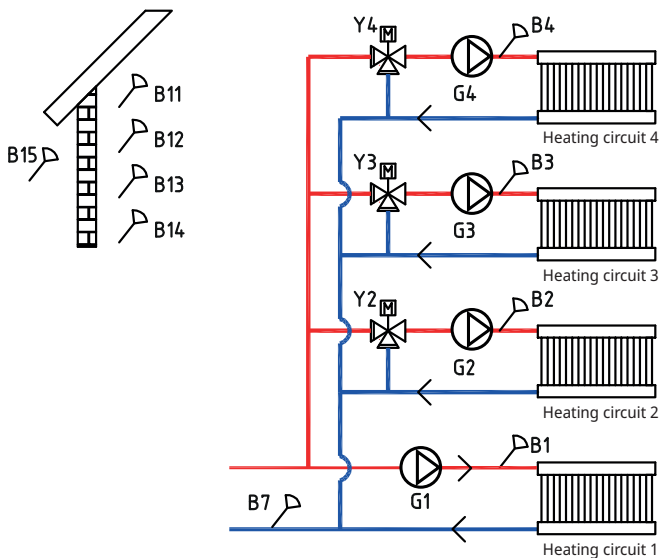

12.2.2 System types 2 and 3 - Heat pumps

Up to 10 heat pumps (HP1 to HP10) can be fitted together with their respective charge pumps (G11 to G20).

Charge pumps 1 and 2 (G11 and G12) can be controlled from CTC EcoLogic, while charge pumps G13 to G20 are controlled from their respective heat pumps.

Heat pumps 1 and 2 can be connected using 3-way valves that direct the flow either to the DHW system or the heating circuit. If more heat pumps are installed, these should be connected to the heating circuit.

The heat pumps are powered separately, not through CTC EcoLogic.

Refer to the heat pump's "Installation and Maintenance Manual" for more information.

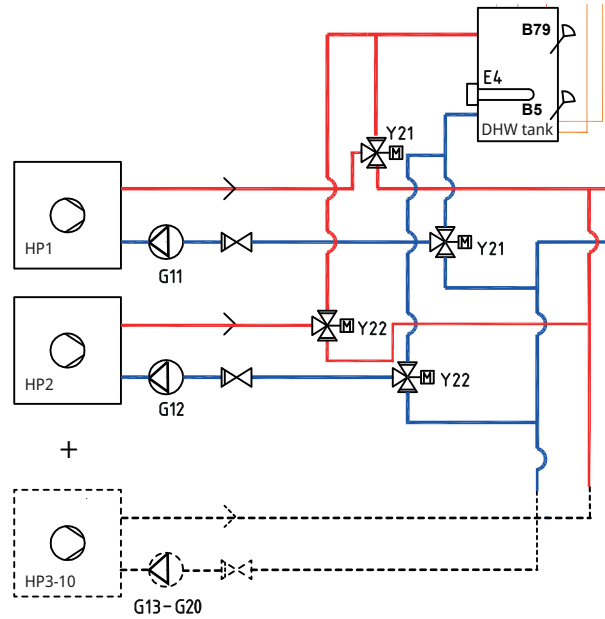

12.2.3 System types 2 and 3 - DHW

In system type 3, the DHW tank can be equipped with an immersion heater (E4) if additional heat (E1, E2 or E3) is installed after the DHW tank. Sensor B5 should be installed in the DHW tank.

DHW circulation is obtained from the pump (G40). Fresh DHW from the DHW tank is mixed in by the mixing valve and chilled water released down into the tank before once more being heated up. The non-return valves are necessary to ensure that circulation proceeds as intended. Control valves allow the desired flow of the circuit to be adjusted.

Option A

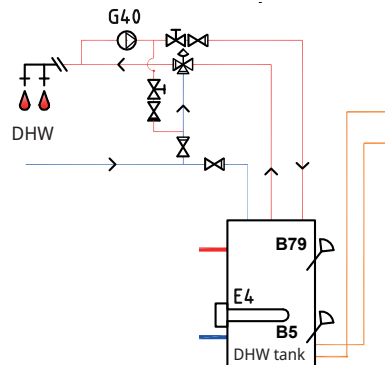

Option B illustrates the possibility of installing one or more DHW tanks which are then connected via a heat exchanger to the lower DHW tank shown in the figure. This solution requires the installation of an external DHW tank sensor (B43) in the external buffer tank, as well as circulation pumps (G41) before and after the heat exchanger.

Option B

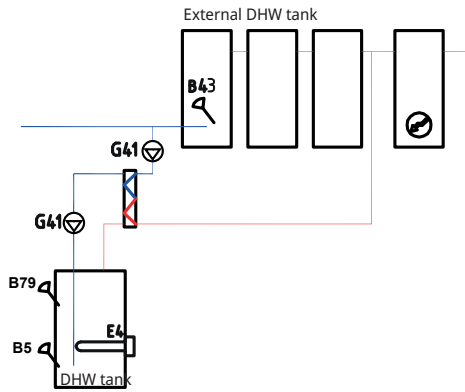

12.2.4 System types 2 and 3 - Additional heat

In system type 2, the additional heat source (E1, E2 or E3) is connected before the DHW tank, while in system type 3 it is connected after the DHW system. Additional heat (E4) can then be connected directly to the tank instead.

When additional heat (E1) is connected, the mixing valve (Y2) is used to connect the additional heat to the system (not to heating circuit 2).

If the buffer tank is connected, the mixing valve (Y4) is used to connect the tank to the system (not to heating circuit 4). Sensor B6 should be installed in the buffer tank.

Sensor B10 should be connected to measure the temperature coming from the additional heat.

System type 2

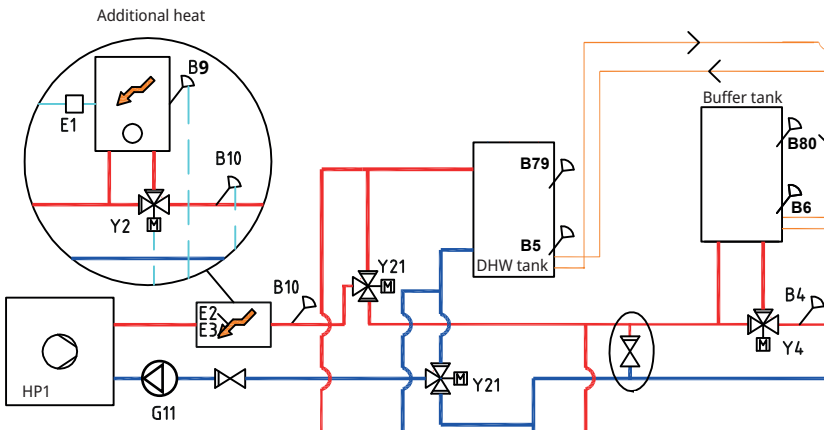

! If charge pump G11 is used for the flow heater, the control signal must be taken from CTC EcoLogic.

System type 3

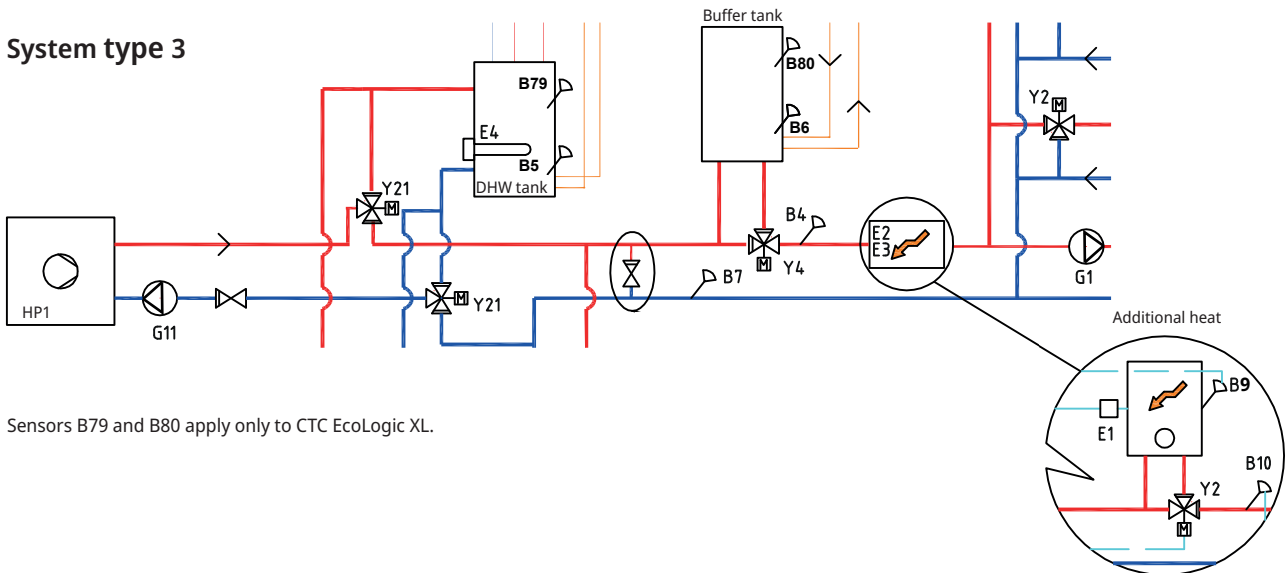

Sensors B79 and B80 apply only to CTC EcoLogic XL.

12.2.5 System types 2 and 3 - Passive cooling

If the passive cooling function is defined, mixing valve Y3, charge pump G3 and sensor B3 should be used for the cooling installation (not heating circuit 3). For details on how to connect, see the Installation and Maintenance instructions for the passive cooling installation.

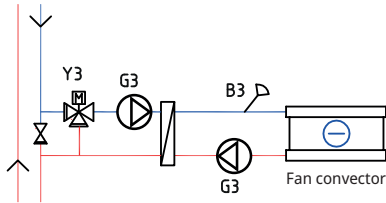

12.2.6 System types 2 and 3 - Solar heating

From the solar collectors, the heat flow is directed to the DHW tank/buffer tank or to the ground heating coil in order to recharge the borehole/ground once the DHW tank is fully charged.

The speed-controlled pump (G30) and sensors B31 and B30 are fitted next to the solar collectors.

For recharging the borehole/ground, a 3-way valve (Y31), heat exchanger and charge pump (G31) are connected.

The 3-way valve (Y30) is fitted together with the speed-controlled pump (G32) and heat exchanger in order to direct the flow towards the DHW tank or the buffer tank. Heat exchangers and pumps (G32) do not need to be installed to the solar heating circuit if there is already a loop in the connected DHW/heating tank.

When the recharging function is in operation, CTC EcoLogic also starts the brine pump in the heat pump (CTC EcoPart). The charge pump for recharging the borehole (G31) ensures there is enough flow through the heat exchanger.

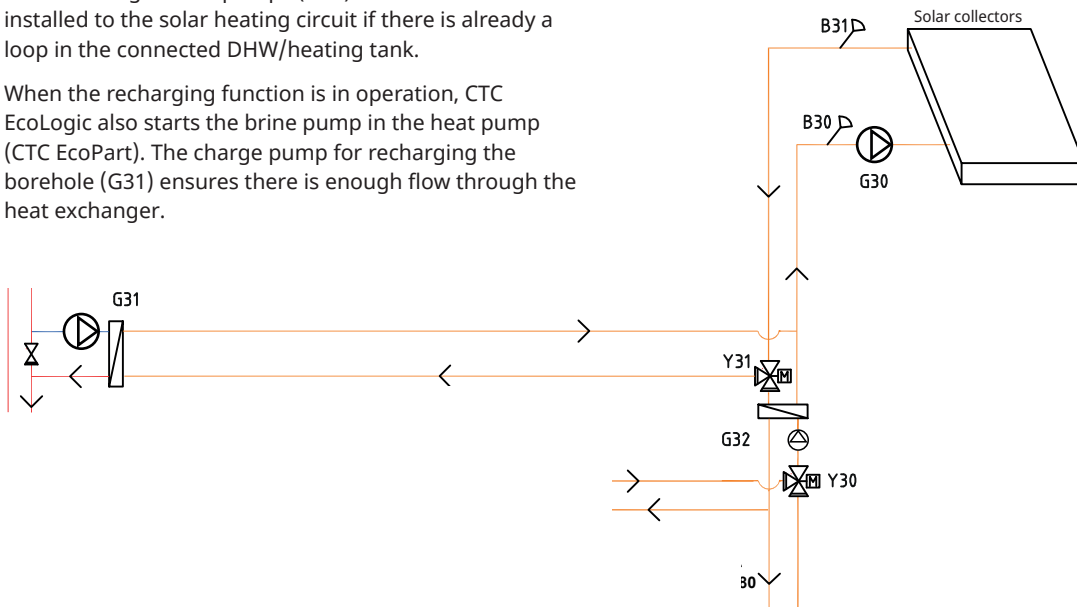

12.3 System types 4 and 5*

The configuration of EcoLogic systems 4 and 5 differ in terms of the location of the additional heat source. For a description of active cooling for system types 4 and 5, see chapter "Active cooling".

System type 4

System type 4 includes pool heating.

All heating from the heat pumps and additional heat goes to the heating circuit through the buffer tank, which maintains a constant temperature to the heating circuit.

In system type 4, the additional heat is located before the DHW system, while in system type 5 it is located after the DHW system.

Heat pumps 1 and 2 can be connected using 3-way valves that direct the heat flow either to the DHW system or the heating circuit. The other heat pumps are connected to the heating circuit.

Solar heating can be connected either to the DHW tank or to a buffer tank using 3-way valves, or to a ground heating coil. Cooling can easily be connected to the borehole/ground source heating circuit.

- * CTC EcoLogic M system types 4 and 5 do not include the following subsystems and associated pumps, valves and sensors:
- Heat pumps 3-10
 - Heating circuits 3 and 4
 - Cooling
 - Recharging borehole
 - Solar energy
 - DHW circulation
 - External DHW tank
 - Pool

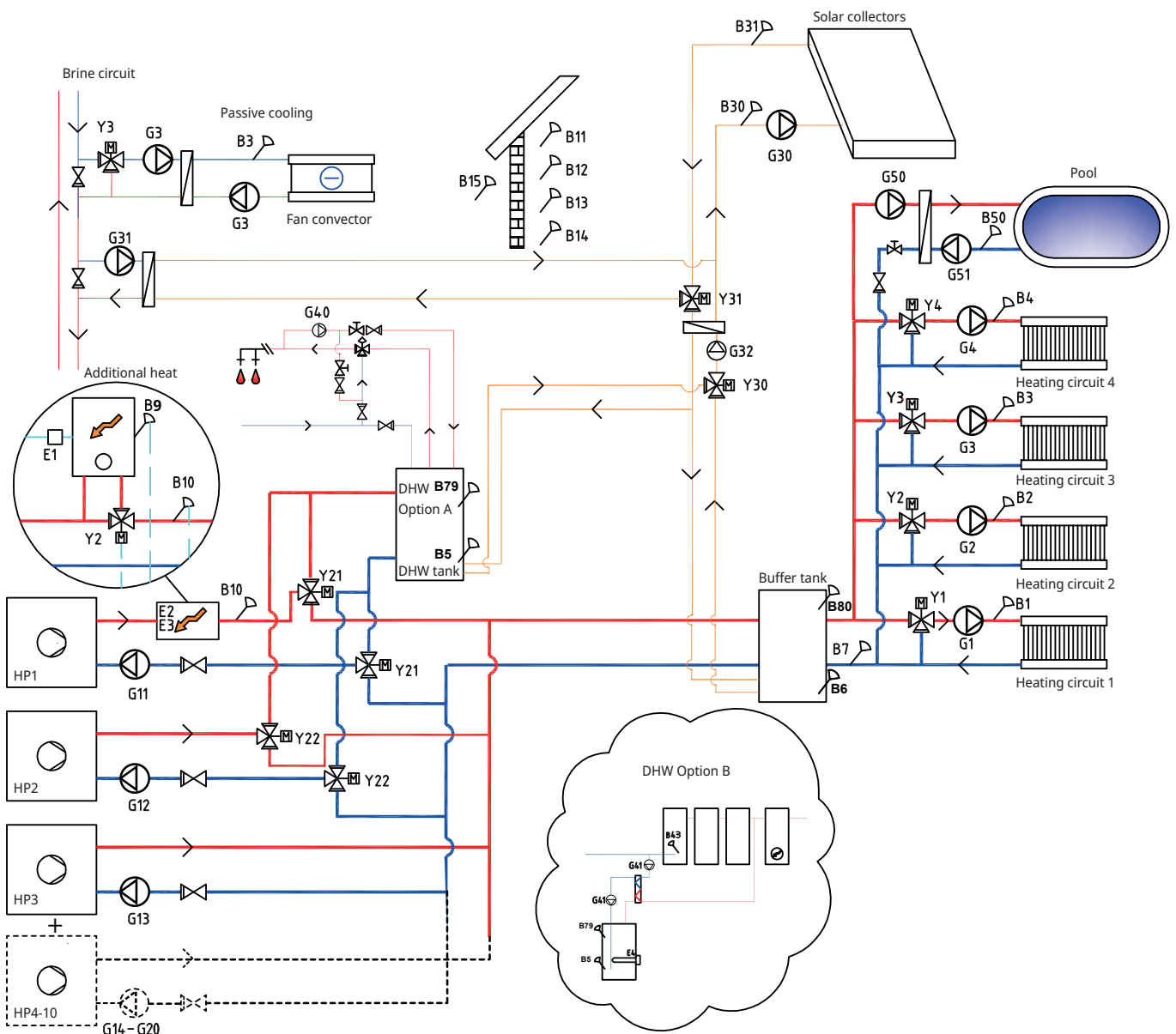

System type 5

All heating from the heat pumps and additional heat goes to the heating circuit through the buffer tank, which maintains a constant temperature to the heating circuit.

In system type 5, the additional heat is located after the DHW system, while in system type 4 it is located before the DHW system.

Heat pumps 1 and 2 can be connected using 3-way valves that direct the flow either to the DHW system or the heating circuit. The other heat pumps are connected to the heating circuit.

Solar heating can be connected either to the DHW tank or to a buffer tank using 3-way valves, or to a ground heating coil.

Cooling can easily be connected to the borehole/ground source heating circuit.

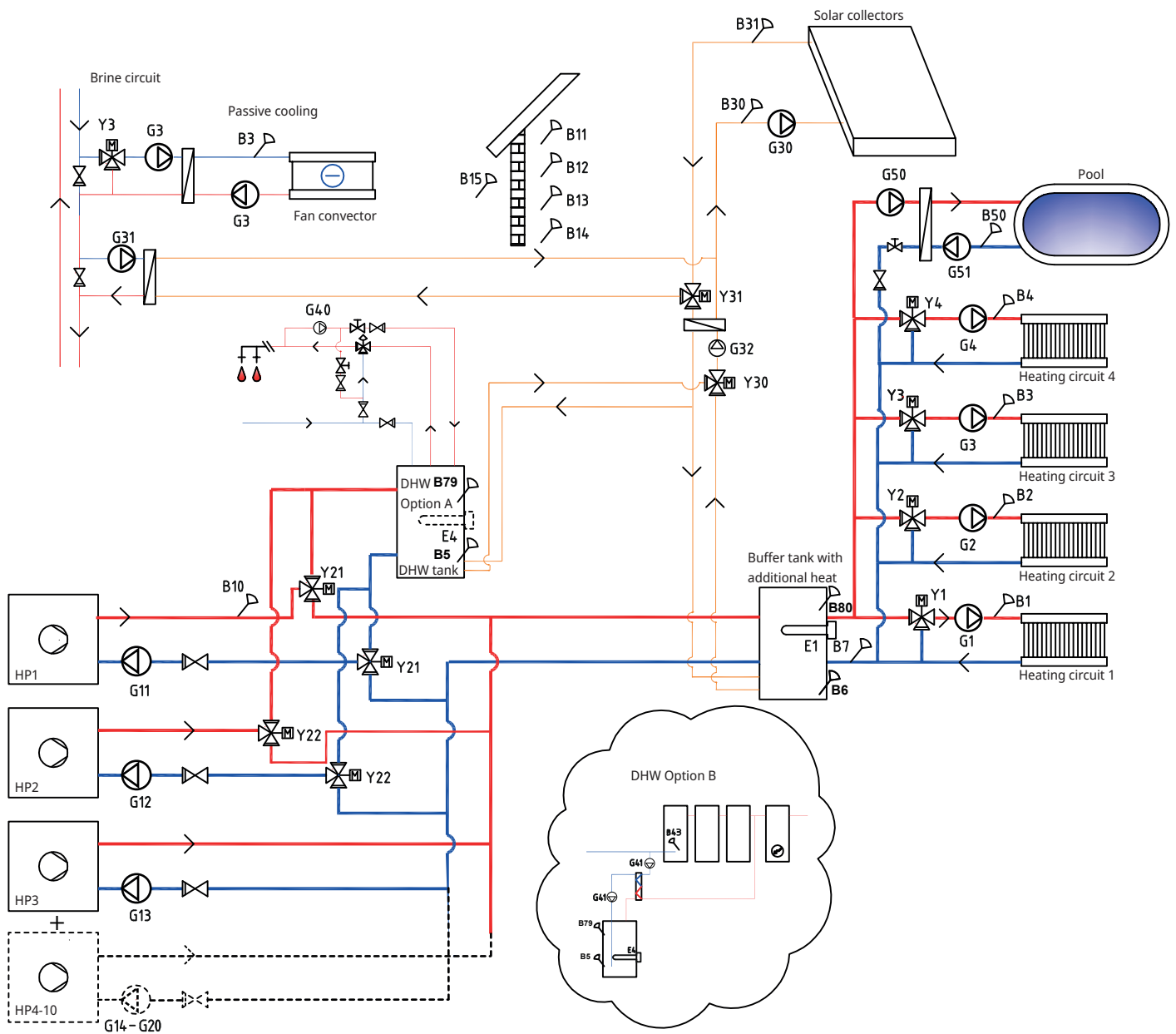

12.3.1 System types 4 and 5 - Heating circuit

CTC EcoLogic can be connected to four different heating circuits, each with separate room sensors. Heating circuits 1 to 4 are connected via mixing valves (Y1, Y2, Y3 and Y4).

For system type 4, if additional heat (E1) is defined, the mixing valve (Y2) should be used to connect additional heat to the system (not to heating circuit 2).

The outdoor sensor (B15) must be fitted to the outer wall of the house, protected from direct sunlight. It is connected using a 2-core cable (min 0.5 mm²).

The room sensors (B11 to B14) must be fitted in an open space in the property where a representative temperature is expected. They are connected using a 3-core cable (min 0.5 mm²).

The primary flow sensors (B1 to B4) must be placed on the primary flow of the respective heating circuit.

The sensor (B7) is placed on the return flow from the heating circuit.

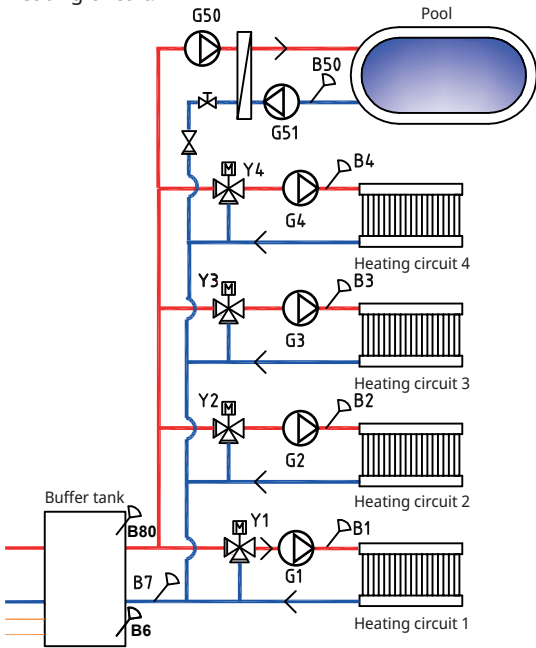

12.3.2 System types 4 and 5 - Heat pumps

Up to 10 heat pumps (HP1 to HP10) can be fitted together with their respective charge pumps (G11 to G20).

Charge pumps 1 and 2 (G11 and G12) can be controlled from CTC EcoLogic, while charge pumps G13 to G20 are controlled from their respective heat pumps.

Heat pumps 1 and 2 can be connected using 3-way valves that direct the flow either to the DHW system or the heating circuit. If more heat pumps are installed, these should be connected to the heating circuit. Be careful to ensure that the ports on the valves are installed correctly.

In system type 4, the primary flow from heat pump 1 is connected to the additional heat as shown in the figure above.

The heat pumps are powered separately, not through CTC EcoLogic.

Refer to the heat pump's "Installation and Maintenance Manual" for more information.

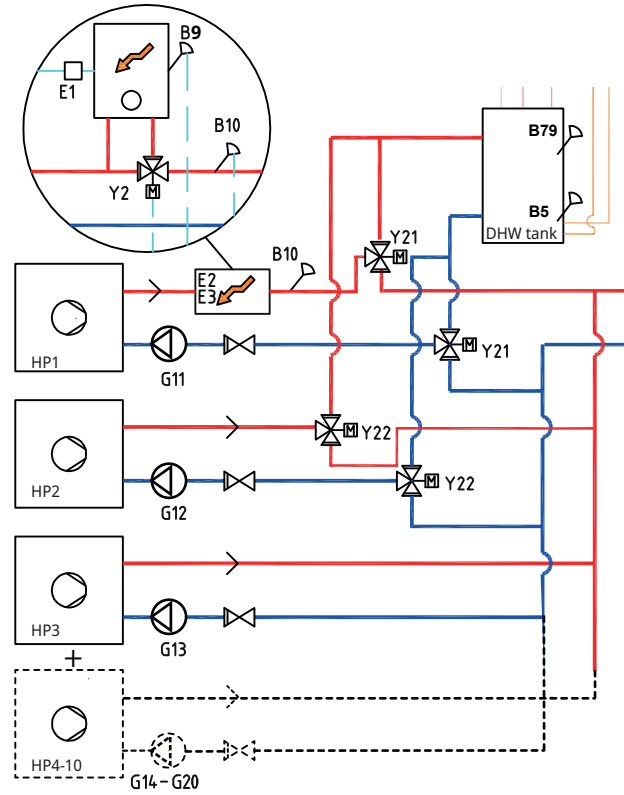

12.3.3 System types 4 and 5 - DHW

In system type 5, the DHW tank can be equipped with an immersion heater (E4) since additional heat (E1, E2 or E3) has not been installed before the DHW tank (as in system type 4). Sensor B5 should be installed in the DHW tank.

DHW circulation is obtained from the pump (G40). Fresh DHW from the DHW tank is mixed in by the mixing valve and chilled water released down into the tank before once more being heated up. The non-return valves are necessary to ensure that circulation proceeds as intended. Control valves allow the desired flow of the circuit to be adjusted.

Option A

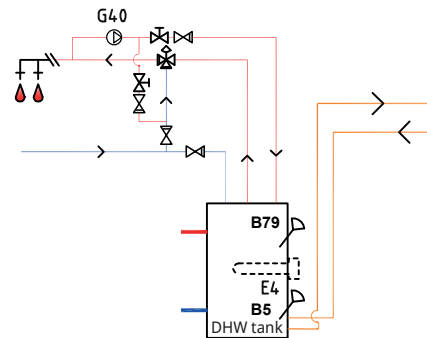

Option B illustrates the possibility of installing (a) DHW tank(s) which is/are then connected via a heat exchanger to the lower DHW tank shown in the figure. This solution requires the installation of an external DHW tank sensor (B43) in the external buffer tank, as well as circulation pumps (G41) before and after the heat exchanger.

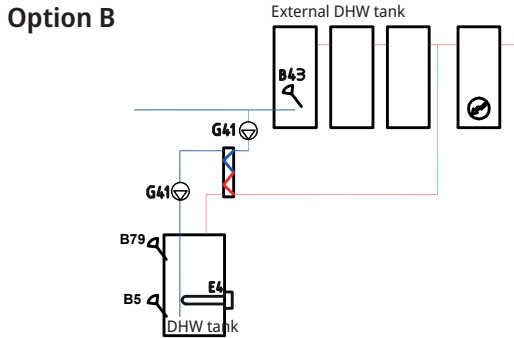

12.3.4 System types 4 and 5 - Additional heat

In system type 4, the additional heat source (E1, E2 or E3) is connected before the DHW system as shown in the figure. When additional heat (E1) is connected, the mixing valve (Y2) is used to connect the additional heat to the system (not to heating circuit 2).

Sensor B10 should be connected to measure the temperature coming from the additional heat.

System type 4

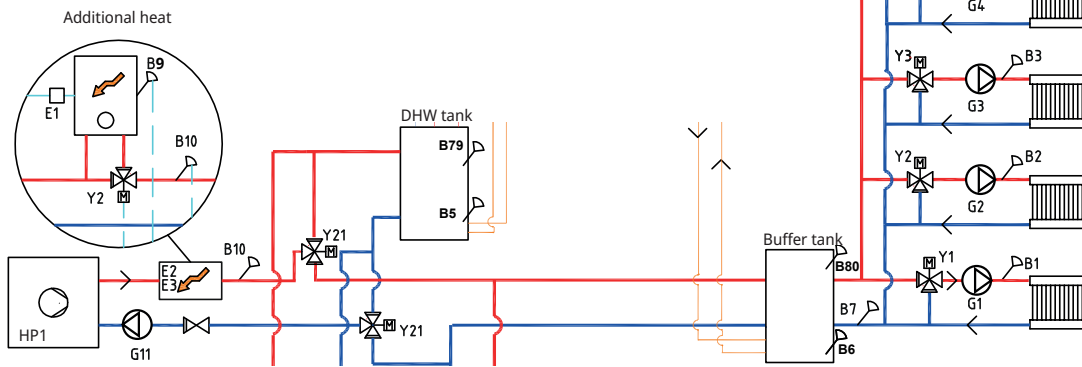

In system type 5, the tip heat (E1) is connected to the buffer tank. The DHW tank can then be provided with additional heat (E4).

System type 5

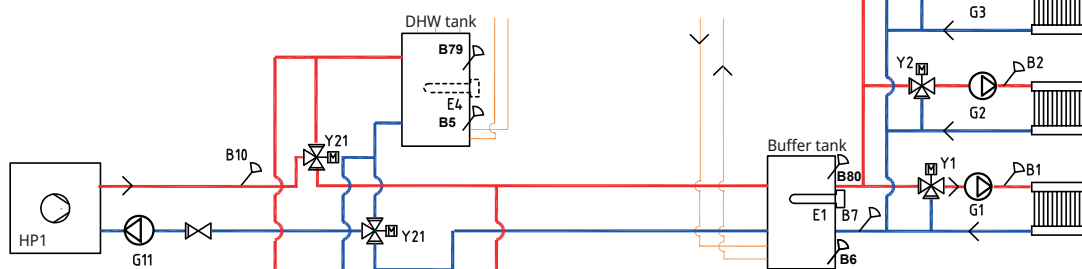

! If charge pump G11 is used for the flow heater, the control signal must be taken from CTC EcoLogic.

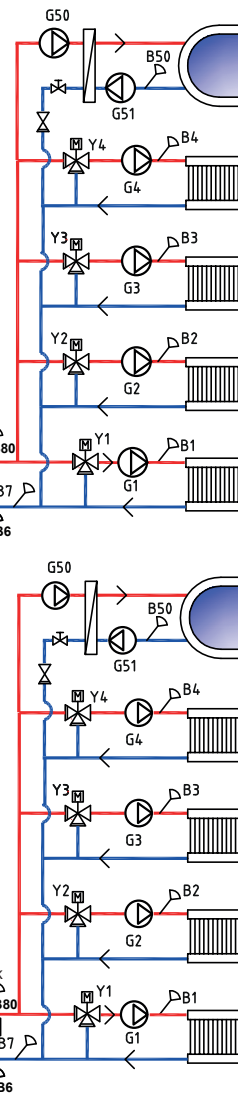

12.3.5 System types 4 and 5 - Passive cooling

If the passive cooling function is defined, mixing valve Y3, charge pump G3 and sensor B3 should be used for the cooling installation (not heating circuit 3). For details on how to connect, see the Installation and Maintenance instructions for the passive cooling installation.

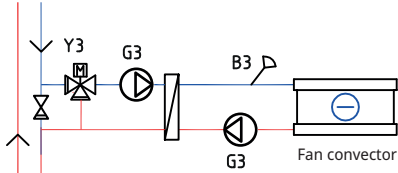

12.3.6 System types 4 and 5 - Pool

The pool can be connected in parallel with the heating circuit.

Charge pump G50 and circulation pump G51 are connected with sensor B50 and the heat exchanger.

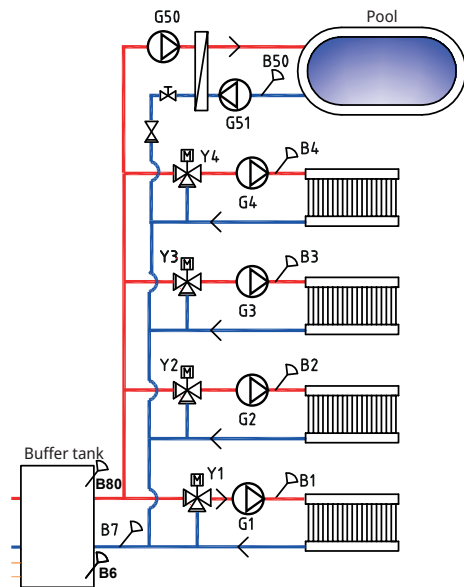

12.3.7 System types 4 and 5 - Solar heating

From the solar collectors, the heat flow is directed to the DHW tank/buffer tank or to the ground heating coil in order to recharge the borehole/ground once the DHW tank is fully charged.

The speed-controlled pump (G30) and sensors B31 and B30 are fitted next to the solar collectors.

For recharging the borehole/ground, a 3-way valve (Y31), heat exchanger and charge pump (G31) are connected.

The 3-way valve (Y30) is fitted together with the speed-controlled pump (G32) and heat exchanger in order to direct the flow towards the DHW tank or the buffer tank. Heat exchangers and pumps (G32) do not need to be installed to the solar heating circuit if there is already a loop in the connected DHW/heating tank.

When the recharging function is in operation, CTC EcoLogic also starts the brine pump in the heat pump (CTC EcoPart). The charge pump for recharging the borehole (G31) ensures there is enough flow through the heat exchanger.

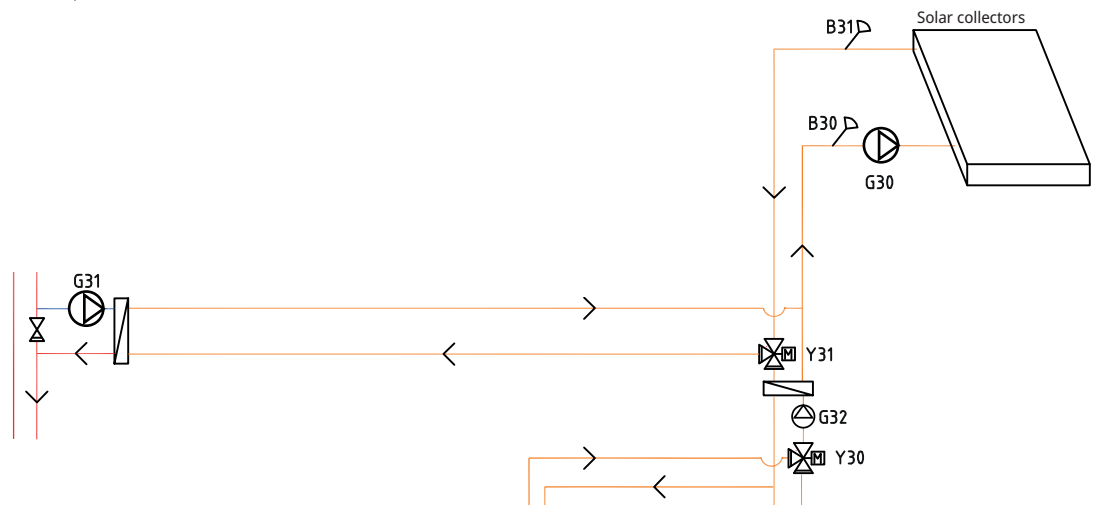

12.4 System type 6*

System type 6 includes pool heating.

Additional heat can be mixed with heating from the buffer tank and output into the heating circuit by a bivalent mixing valve (Y1).

Heat pumps 1 and 2 can be connected using 3-way valves that direct the flow either to the DHW system or the heating circuit. The other heat pumps are connected to the heating circuit.

Solar heating can be connected either to the DHW tank or to a buffer tank using 3-way valves, or to a ground heating coil.

Cooling can easily be connected to the borehole/ground source heating circuit.

* CTC EcoLogic M system type 6, does not include the following subsystems and their associated pumps, valves and sensors:

- Heat pumps 3 to 10
- Heating circuits 3 and 4
- Cooling
- Recharging borehole
- Solar energy
- DHW circulation
- External DHW tank
- Pool

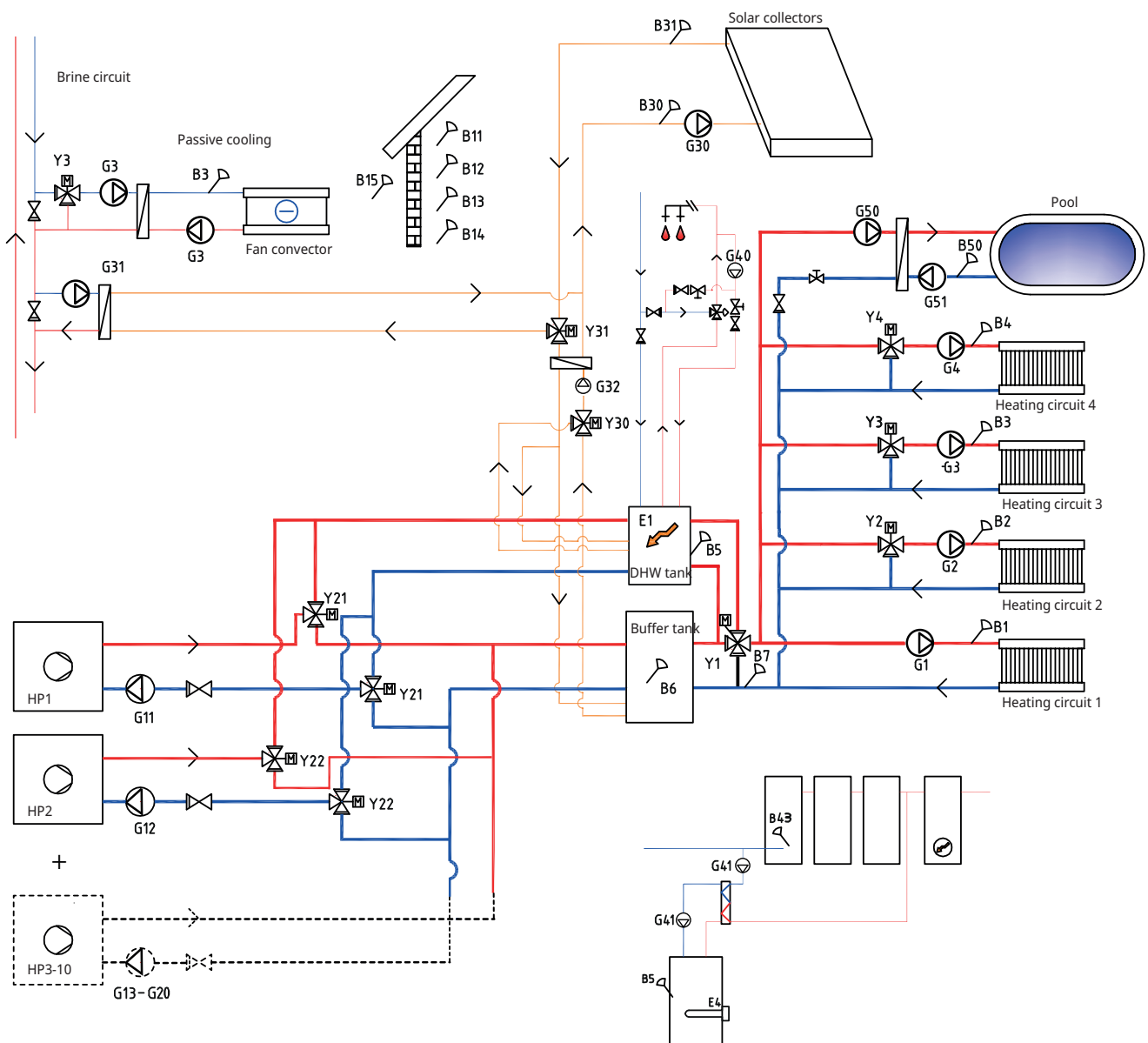

12.4.1 System type 6 - Heating circuit

CTC EcoLogic can be connected to four different heating circuits, each with separate room sensors. Heating circuits 2, 3 and 4 are connected via mixing valves (Y2, Y3 and Y4).

The outdoor sensor (B15) must be fitted to the outer wall of the house, protected from direct sunlight. It is connected using a 2-core cable (min 0.5 mm²).

The room sensors (B11 to B14) must be fitted in an open space in the property where a representative temperature is expected. They are connected using a 3-core cable (min 0.5 mm²).

The primary flow sensors (B1 to B4) must be placed on the primary flow of the respective heating circuit.

The sensor (B7) is placed on the return flow from the heating circuit.

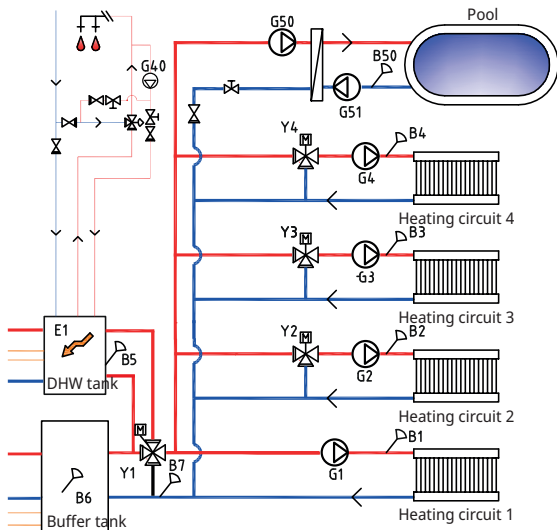

12.4.2 System type 6 - Heat pumps

Up to 10 heat pumps (HP1 to HP10) can be fitted together with their respective charge pumps (G11 to G20).

Charge pumps 1 and 2 (G11 and G12) can be controlled from CTC EcoLogic, while charge pumps G13 to G20 are controlled from their respective heat pumps.

Heat pumps 1 and 2 can be connected using 3-way valves that direct the flow either to the DHW system or the heating circuit. If more heat pumps are installed, these should be connected to the heating circuit. Be careful to ensure that the ports on the valves are installed correctly.

The heat pumps are powered separately, not through CTC EcoLogic.

Refer to the heat pump's "Installation and Maintenance Manual" for more information.

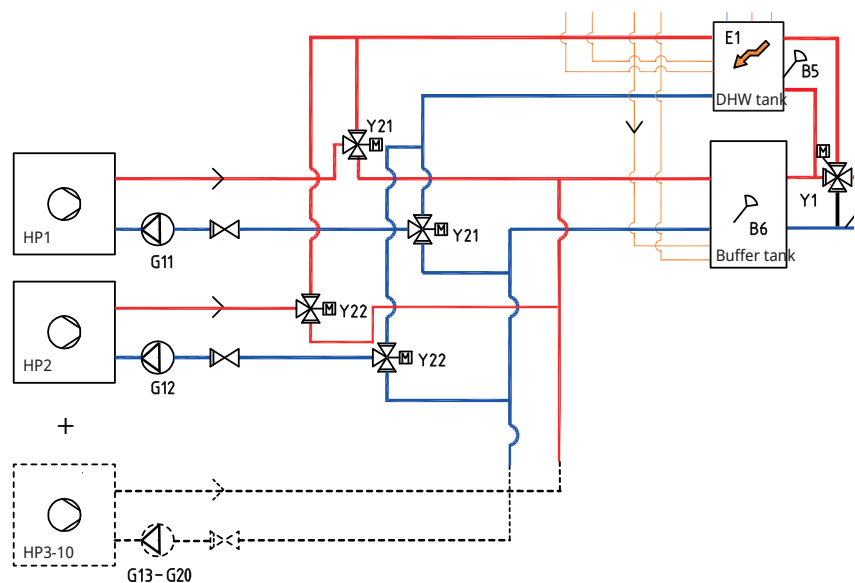

12.4.3 System type 6 - DHW

The DHW tank and additional heat E1 are connected to a 4-way bivalent mixing valve (Y1).

Sensor B5 should be installed in the DHW tank.

DHW circulation is obtained from the pump (G40). Fresh DHW from the DHW tank is mixed in by the mixing valve and chilled water released down into the tank before once more being heated up. The non-return valves are necessary to ensure that circulation proceeds as intended. Control valves allow the desired flow of the circuit to be adjusted.

Option A

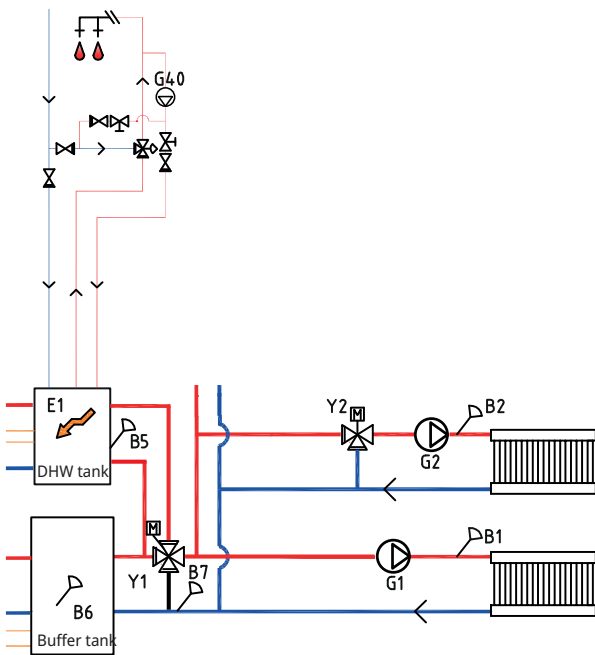

Option B illustrates the possibility of installing one or more DHW tanks which are then connected via a heat exchanger to the lower DHW tank shown in the figure. This solution requires the installation of an external DHW tank sensor (B43) in the external buffer tank, as well as circulation pumps (G41) before and after the heat exchanger.

Option B

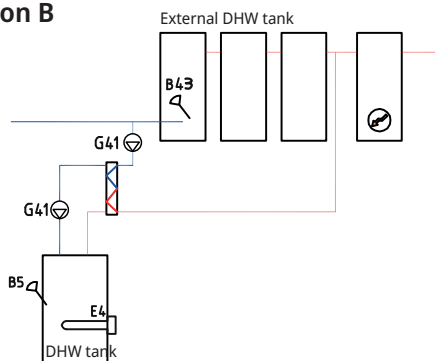

12.4.4 System type 6 - Additional heat

Additional heat E1 is connected to the DHW tank and connected to the heating circuit in parallel with the buffer tank using a 4-way bivalent mixing valve.

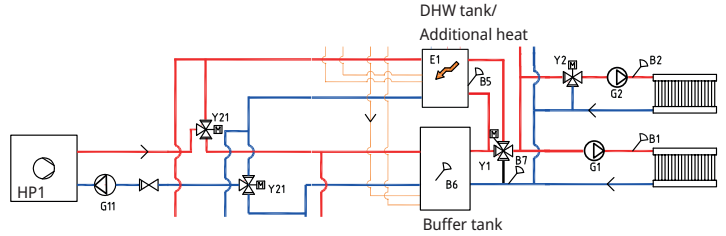

12.4.5 System type 6 - Passive cooling

If the passive cooling function is defined, mixing valve Y3, charge pump G3 and sensor B3 should be used for the cooling installation (not heating circuit 3). For details on how to connect, see the Installation and Maintenance instructions for the passive cooling installation.

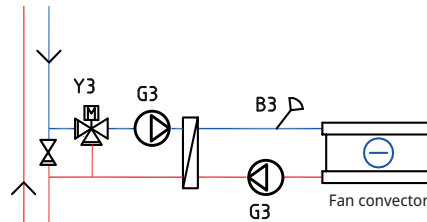

12.4.6 System type 6 - Pool

The pool can be connected in parallel with the heating circuit as shown in the figure below.

Charge pump G50 and circulation pump G51 are connected with sensor B50 and the heat exchanger.

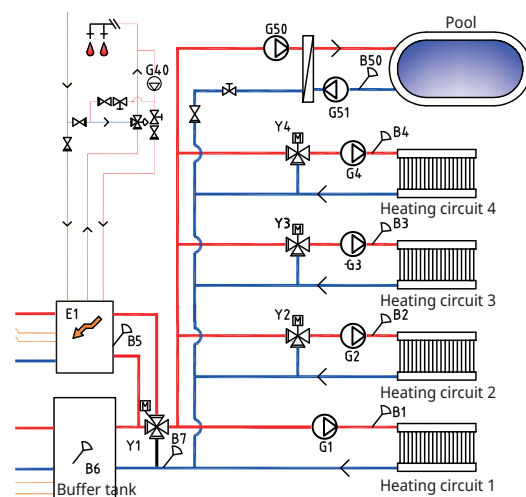

12.4.7 System type 6 - Solar heating

From the solar collectors, the heat flow is directed to the DHW tank/buffer tank or to the ground heating coil in order to recharge the borehole/ground once the DHW tank is fully charged.

The speed-controlled pump (G30) and sensors B31 and B30 are fitted next to the solar collectors.

For recharging the borehole/ground, a 3-way valve (Y31), heat exchanger and charge pump (G31) are connected.

The 3-way valve (Y30) is fitted together with the speed-controlled pump (G32) and heat exchanger in order to direct the flow towards the DHW tank or the buffer tank. Heat exchangers and pumps (G32) do not need to be installed to the solar heating circuit if there is already a loop in the connected DHW/heating tank.

When the recharging function is in operation, CTC EcoLogic also starts the brine pump in the heat pump (CTC EcoPart). The charge pump for recharging the borehole (G31) ensures there is enough flow through the heat exchanger.

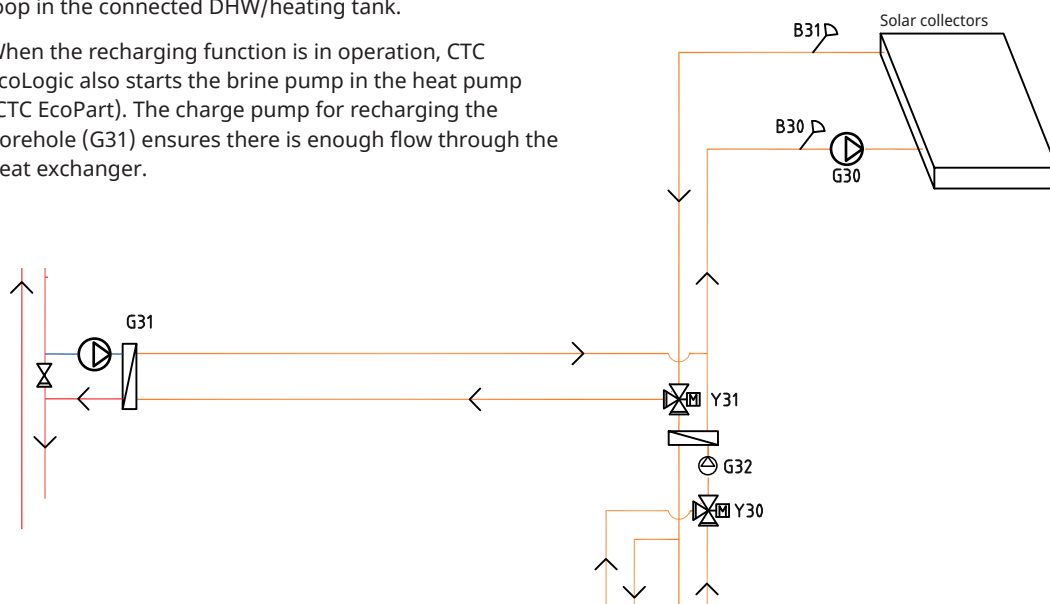

13. Valves

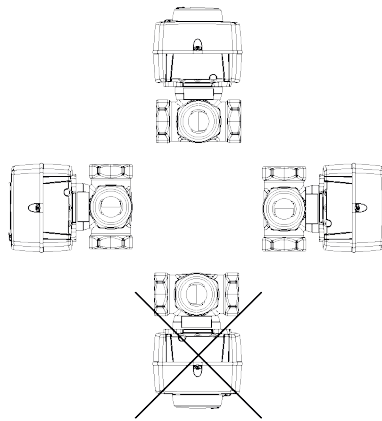

13.1 Three-way mixing valve

13.1.1 Three-way mixing valve VRG 131 ARA 671

Installation options with CTC's three-way mixing valves.

Note the importance of the connections and the positioning of the shaft coupling.

Connection as per 1 and 2

The motor must move in a clockwise direction to close.

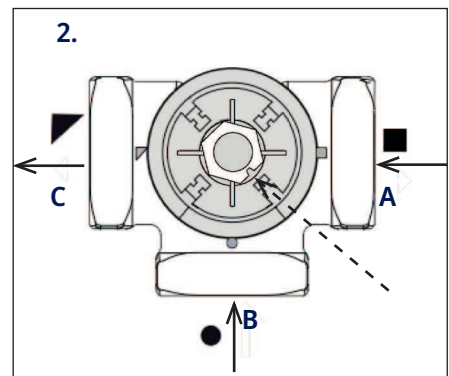
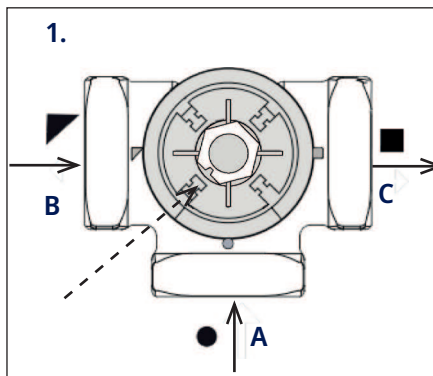
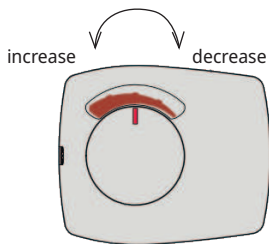

Connection as per 3 and 4

The motor must move in an anticlockwise direction to close.

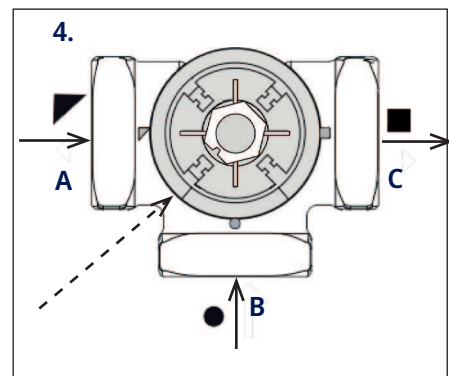
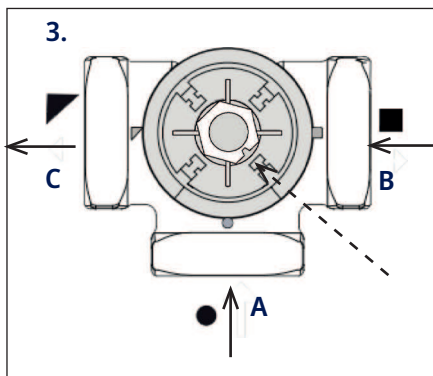
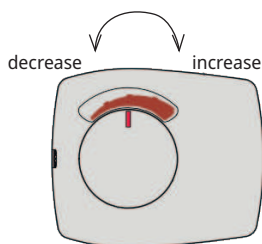

The mixing valve motor is mounted on the valve with the knob in the centre position.

	System 1	Other connection methods
A	From the heat pump (also distributed to the boiler's return connection)	Return flow
B	Boiler water (from the boiler's primary flow)	From the energy source*
C	Radiator primary flow (to port AB on the diverting valve)	Primary flow

* Energy source refers to the energy that the mixing valve utilises as an energy source, i.e. the energy that the valve mixes into the system. Energy can come from an additional boiler, a wood boiler, a solar tank and/or the main pipe in the heating circuit.

13.2 3-way valves

13.2.1 Diverting valve ESBE VRG 230/Ara 635

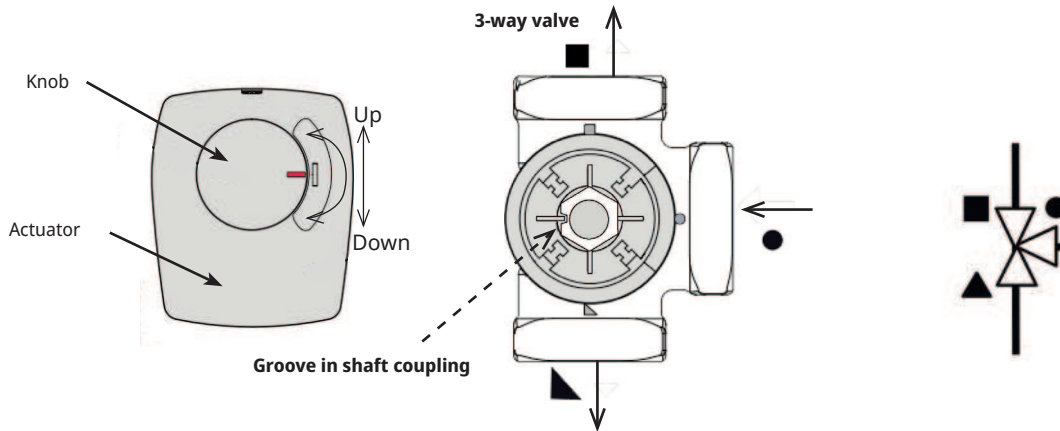

The mixing valve motor is mounted on the valve with the knob in the centre position.

The valve can be mounted inversely, right to left, left to right.

The direction of the motor can be changed using the loop under the actuator cap.

The loop is always connected towards the heat pump.

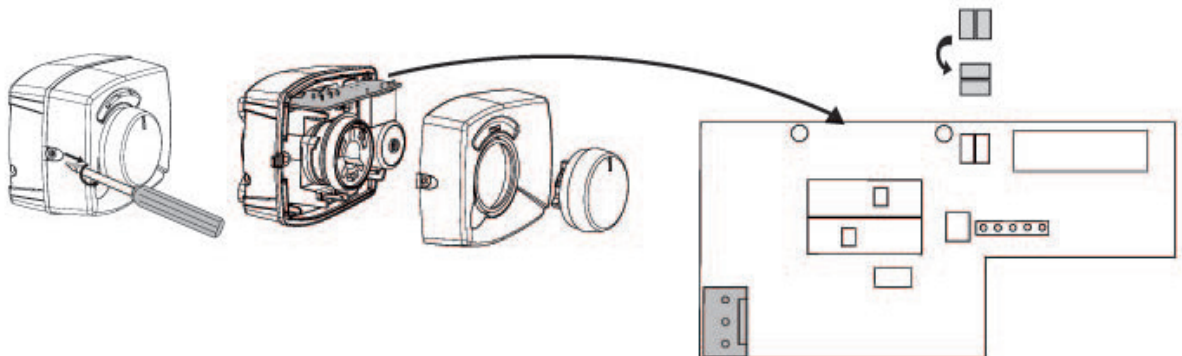

13.2.2 Diverting valve LK EMV 110-K

When the motor transfers power to the black wire, port A opens and port B closes.

Flow AB to A = hot water production and **Black** is powered.

NB: The valve must be "turned round" in order to change direction. The valve must always be fitted so that the flow can move freely.

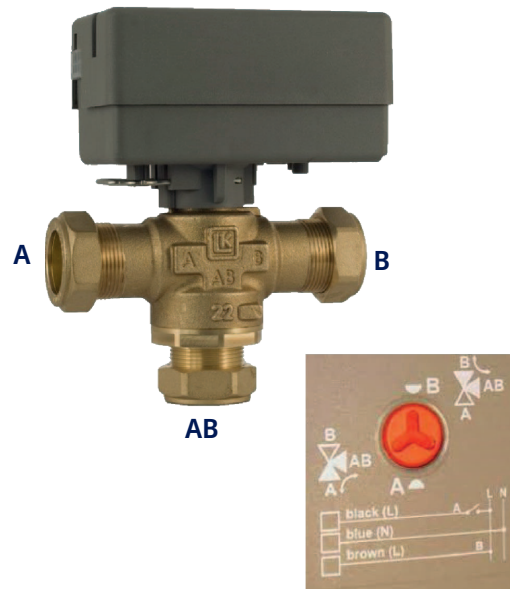

13.3 Bivalent mixing valve

13.3.1 Bivalent mixing valve VRB 141/143 ARA 672

The motor must move in a clockwise direction to close.

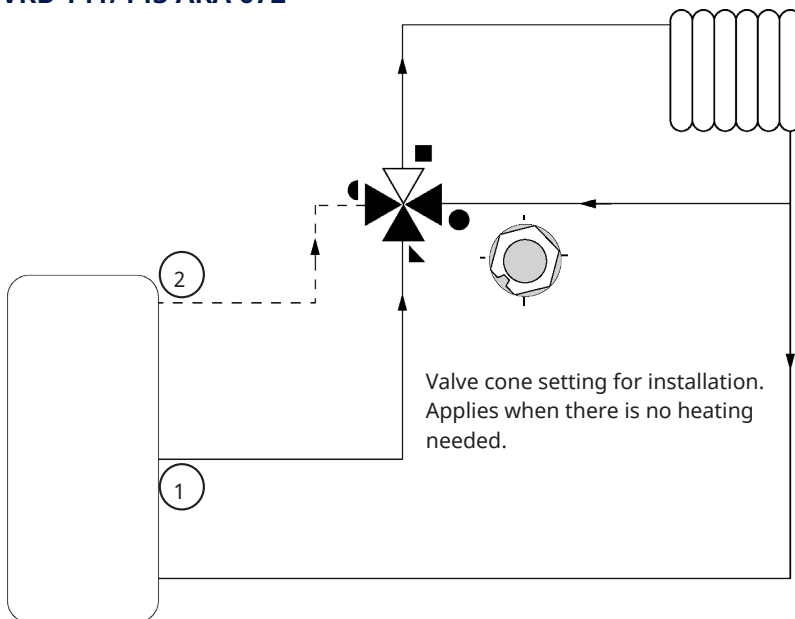
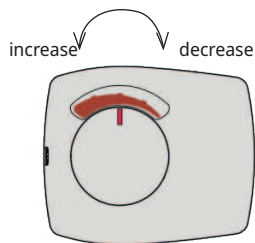

13.3.2 Bivalent mixing valve VRB 243/ARA 672

The motor must move in a clockwise direction to close.

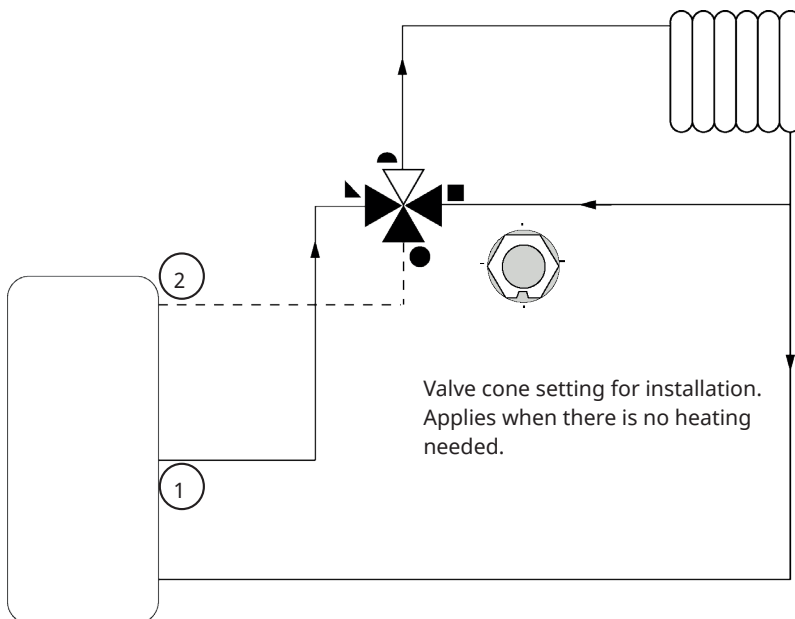
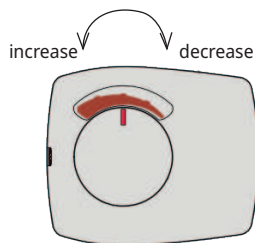

14. Electrical installation

Installation and connections in CTC EcoLogic must be performed by a licenced electrician.

Make sure there is no risk of static electricity; earth yourself by touching an earthed metal component before touching the PCB or a sensor.

All wiring shall be installed according to applicable local requirements.

14.1 High voltage

Supply

230V 1N~

Max fuse size (group fuse) 10A.

Connects to terminal block marked L1, N, PE.

All-pole safety switch

The installation should be preceded by an all-pole safety switch according to overvoltage category III, which ensures disconnection from all electric power sources.

14.1.1 Mixing valves (Y1, Y2, Y3*, Y4*)

230V 1N~

1.5 m cable, 1.5 mm², neutral, open, close.

The mixing valve motors are connected to the PCB/ terminal block:

(Y1) Mixing valve 1, Relay board A2

Open:	pole A27
Close:	pole A28
Neutral:	pole A29
Limit position, bivalent/system 6	pole A22
Limit position, bivalent/system 6	pole A21

(Y2) Mixing valve 2, Relay board A2

Open:	pole A15
Close:	pole A16
Neutral:	pole A17

(Y3) Mixing valve 3, Expansion board A3*

Open:	pole X6:12
Close:	pole X6:13
Neutral:	pole X6:14

(Y4) Mixing valve 4, Expansion board A3*

Open:	pole X7:18
Close:	pole X7:19
Neutral:	pole X7:20

Check that the open and close signals are correctly connected by testing the motor in the "Advanced/Service/Function test" menu.

14.2 Communication between CTC EcoLogic and CTC EcoAir/CTC EcoPart

The communication cable used is an LiYCY (TP) which is 4-core shielded cable, where the communication-bearing cores are of twisted pair type. This should be installed between the CTC EcoLogic terminal blocks G51 (brown), G52 (white), G53 (green) and heat pump 1, from which the other heat pumps can be controlled.

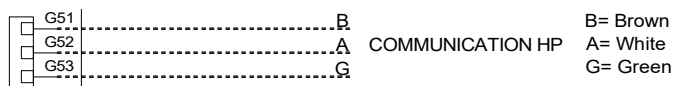

Voltage feed to heat pumps

The heat pumps are powered separately, not from CTC EcoLogic.

14.2.1 Diverting valves (Y21, Y22*)

230V 1N~

2.5 m cable 1.5 mm².

When pole A18 or X7/24 is supplied with power, the flow should be to the DHW system. When they are not supplied with power, flow should be to the heating circuit.

The diverting valves are connected to the following terminal blocks:

(Y21) Diverting valve 1, Relay board A2

Relay output:	pole A18
Phase:	pole A19
Neutral:	pole A20

(Y22) Diverting valve 2, Expansion board A3*

Relay output:	pole X7:24
Phase:	pole X7:25
Neutral:	pole X7:26

Check the function by test running the diverting valve in the "Advanced/Service/Function test" menu in the control system.

In the "DOWN" position on the function menu, port ▲ should be open (turn the knob on the motor clockwise, CW). In the "UP" position, port ■ should be open (turn the knob on the motor counter clockwise, CCW).

The motor is fitted to the diverting valve by a screw. To unfasten the motor: remove the knob by pulling it off, unfasten the screw and remove the motor.

To prevent faults, turn the actuator and diverting valve to the starting position for fitting as shown in the figures. Pull out the knob on the actuator and turn to the central position.

*Applies to CTC EcoLogic XL/L.

Port ● should be completely open; ports ■ and ▲ should be partially open. Ensure that the groove in the white shaft coupling is in position as shown in the figure. The diverting valve and actuator can then be fitted together as shown in the figure or turned in 90-degree steps relative to each other.

If ports ▲ and ■ have been shifted during the hydraulics connection, the motor can be reconnected to change its direction of rotation. This is done using two jumpers inside the motor.

NB: The direction of rotation cannot be changed by swapping the black and brown cables.

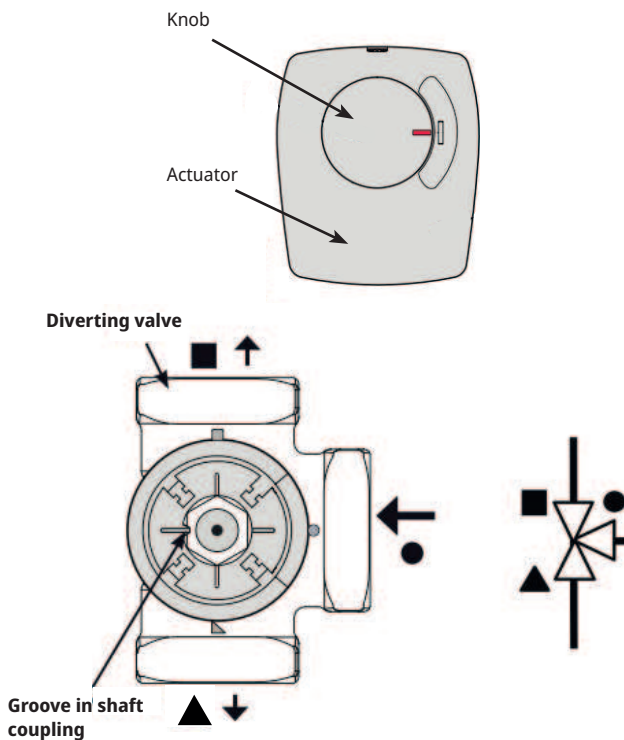

14.2.1.1 Diverting valve, active cooling (Y61*)

230V 1N~
The valve is connected to the following terminal blocks, Expansion board A3.

The valve is activated when heat pumps produce cooling and is installed in systems with a separate heating / cooling tank.

Relay output:	pole X7:30
Neutral:	pole X7:32
Phase:	pole X7:25

Check the function by test running the valve in menu "Advanced/Service/Function test".

14.2.1.2 Diverting valve, active cooling "demand" (Y62*)

230V 1N~
The valve is connected to the following terminal blocks, Expansion board A3.

The valve is activated when required for cooling and installed in systems with a separate heating / cooling tank to avoid heat leakage to the heating tank.

Relay output:	pole X6:8
Neutral:	pole X6:11
Phase:	pole X6:9

Check the function by test running the valve in menu "Advanced/Service/Function test".

14.2.1.3 Diverting valve, heat dumping (Y64*)

230V 1N~
The valve is connected to the following terminal blocks, Expansion board A3.

When active brine cooling is required, the domestic hot water tank and the buffer tank are prioritized for charging with the available excess heat. Once all heating demands are fulfilled, the valve is activated and the excess heat is directed to heat dumping.

Relay output:	pole X6:4
Neutral:	pole X6:7
Phase:	pole X6:5

Check the function by test running the valve in menu "Advanced/Service/Function test".

14.2.1.4 Proportional diverting valve, cooling (Y70)**

230V 1N~
The valve is connected to the following terminal blocks, I/O board A7.

When cooling is required, the valve is activated and distributes available cooling to the cooling tank and/or to the collector, depending on current demand. The valve is equipped with a safety function that protects the cooling exchanger from excessively low temperatures.

GND:	pole (X4-D)-4
PWM:	pole (X4-E)-5

Check the function by test running the valve in menu "Advanced/Service/Function test".

*Applies to CTC EcoLogic XL/L.

**Applies only to CTC EcoLogic XL.

14.2.2 Radiator pumps (G1, G2, G3*, G4*)

230V 1N~

The radiator pumps are connected to the following terminal blocks:

(G1) Radiator pump 1, Relay board A2

Phase:	pole A31
Neutral:	pole A33
GND:	pole PE

(G2) Radiator pump 2, Relay board A2

Phase:	pole A36
Neutral:	pole A34
GND:	pole PE

(G3) Radiator pump 3, Expansion board A3*

Phase:	pole X6:15
Neutral:	pole X6:17
GND:	pole X6:16

(G4) Radiator pump 4, Expansion board A3*

Phase:	pole X7:21
Neutral:	pole X7:23
GND:	pole X7:22

Check that the pump is correctly connected by test running it in "Advanced/Service/Function test" menu.

14.2.3 Charge pumps HP1, HP2, HP3, HP4 (G11, G12, G13*, G14*)

230V 1N~

Charge pumps G11 and G12 can be controlled by CTC EcoLogic, while the system's other charge pumps (G13 to G20) are controlled from their respective heat pumps (HP3 to HP10).

The charge pumps are connected to the following terminal blocks:

(G11) Charge pump 1, Relay board A2

WILO Stratos Para
GRUNDFOS UPM GEO 25-85

Relay output:	A12
PWM+:	G46
GND:	G45



If charge pump G11 is used for the flow heater, the control signal must be taken from CTC EcoLogic.

(G12) Charge pump 2, Relay board A2

WILO Stratos Para
GRUNDFOS UPM GEO 25-85

PWM+:	G48
GND:	G47

(G13) Charge pump 3, Expansion board A3*

WILO Stratos Para
GRUNDFOS UPM GEO 25-85

PWM+:	pole X5:5
GND:	pole X5:6

(G14) Charge pump 4, Expansion board A3*

WILO Stratos Para
GRUNDFOS UPM GEO 25-85

PWM+:	pole X5:7
GND:	pole X5:8

Check that the pump is correctly connected by test running it in "Advanced/Service/Function test" menu.

14.2.4 Additional heat (E1, E2, E3, E4)

The additional heat sources can be connected to the following terminal blocks:

(E1) Relay output, Relay board A2

Relay output:	pole A11
---------------	----------

(E2) 0-10V, Expansion board A3*

Analogue output 0-10V	pole X5:9
GND	pole X5:10

(E2) 0-1 step, 0-3 steps, 0-7 steps, Relay board A2***

Relay output, Step 1	EL1A
Relay output, Step 2	EL1B
Relay output, Step 3	EL1A+EL1B
Relay output, Step 4	EL2A
Relay output, Step 5	EL1A+EL2A
Relay output, Step 6	EL1B+EL2A
Relay output, Step 7	EL1A+EL1B+EL2A

(E3) EcoMiniEI, Relay board A2

Comm. 230V	A30
------------	-----

NB: CTC EcoLogic and CTC EcoMiniEI must have a common connection to the neutral terminal.

(E4) Additional heat DHW, Relay board A2

Relay output:	pole A13
---------------	----------

*Applies to CTC EcoLogic XL/L.

**Applies only to CTC EcoLogic XL.

***Connect max. 13 A per relay (EL1A, EL2A and EL3A). At higher current, connect via contactor.

14.2.5 Circulation pump, DHW (G40*)

230V 1N~

The circulation pump is connected to the following terminal blocks:

(G40) Circulation Pump, Expansion board A3*

Phase:	pole X6:1
Neutral:	pole X6:3
GND:	pole X6:2

Check that the pump is correctly connected by test running it in "Advanced/Service/Function test" menu.

14.2.6 Pump, external DHW tank (G41*)

230V 1N~

The pump is connected to the following terminal blocks:

(G41) Charge pump, Expansion board A3*

Phase:	pole X7:27
Neutral:	pole X7:29
GND:	pole X7:28

Check that the pump is correctly connected by test running it in "Advanced/Service/Function test" menu.

14.2.7 Pumps, Solar collector (G30*, G32*)

The PWM pump G30 differ from the other PWM pumps. If the PWM control signal is interrupted, the solar pump must stop, whereas the other PWM pumps work at 100% power if the signal is interrupted.

At 0% control signal to the pump G30, the pump speed must be at 0%. For other pumps 0% control signal must equal 100% pump speed.

14.2.7.1 Circulation pump, solar collector (G30)

230V 1N~

The circulation pump is connected to the following terminal blocks:

(G30) Circulation pump, Expansion board A3*

PWM+:	pole X5:1
GND:	pole X5:2

Check the function by test running the pump in the "Advanced/Service/Function test" menu.

14.2.7.2 Pump, heat exchanger solar collector (G32)

230V 1N~

The pump is connected to the following terminal blocks:

(G32) Pump, Expansion board A3*

PWM+:	pole X5:3
GND:	pole X5:4

Check the function by test running the pump in the "Advanced/Service/Function test" menu.

14.2.8 Diverting valve, solar collector DHW (Y30*)

230V 1N~

The diverting valve is connected to the following terminal blocks:

(Y30) Diverting valve, Expansion board A3*

Control voltage:	pole X6:4
Phase:	pole X6:5
Neutral:	pole X6:7
GND:	pole X6:6

14.2.9 Solar collector, recharging borehole (Y31/G31*)

14.2.9.1 Diverting valve, Solar collector (Y31)

230V 1N~

NOTE! It is important to connect the phase voltage to L (pole 9), see the wiring diagram.

The diverting valve is connected to the following terminal blocks:

(Y31) Diverting valve, Expansion board A3*

Relay output:	Open to borehole	pole X6:8 also controls the pump, recharging borehole (G31)
Phase:	Open Tank	pole X6:9
Neutral:		pole X6:11

Valve 582581001 (see image) must only be connected with relay output, X6 pole 8 and neutral, X6 pole 11.

582581001 22 3/4"



Pole 8 is connected to an external connection box which distributes voltage to the diverting valve, solar collector (Y31) and the pump, recharge borehole (G31), see the wiring diagram.

Check the function by test running the valve in the "Advanced/Service/Function test" menu.

14.2.9.2 Pump, recharging borehole (G31*)

230V 1N~

The pump is connected at the following terminal blocks:

(G31) Pump, Expansion board A3*

Phase:	pole X6:8 also controls the diverting valve, solar collector (Y31)
Neutral:	pole X6:11
GND:	pole X6:10

Pole 8 is connected to an external connection box which distributes voltage to the diverting valve, solar collector (Y31) and the pump, recharge borehole (G31), see the wiring diagram.

Check the function by test running the pump in menu "Advanced/Service/Function test".

*Applies to CTC EcoLogic XL/L.

14.2.10 Pool pumps (G50*, G51*)

230V 1N~

Both pumps G50 and G51 are connected to the following terminal blocks:

(G50, G51) Pool pumps, Expansion board A3*

Phase:	pole X7:33
Neutral:	pole X7:35
GND:	pole X7:34

Pole 33 is connected to an external connection box which distributes voltage to the charge pump (G50) and circulation pump (G51).

Check the function by test running the pump in the "Advanced/Service/Function test" menu.

14.2.11 Pump, brine heat dumping (G52)**

230V 1N~

The pump is connected at the following terminal blocks:

(G52) Pump, I/O board A7**

GND:	pole (X4-A)-1
PWM:	pole (X4-B)-2

Check the function by test running the pump in menu "Advanced/Service/Function test".

14.2.12 Charge pump, heat exchanger cooling tank (G53)**

230V 1N~

The charge pump is connected at the following terminal blocks:

(G53) Charge pump, I/O board A7**

PWM:	pole (X4-C)-3
GND:	pole (X4-D)-4

Check the function by test running the pump in menu "Advanced/Service/Function test".

14.3 Protection – low voltage (sensor)

The sensors that form part of each system solution (schematic diagrams 1 to 6) should be fitted to the PCB/terminal block as follows:

All sensors are temperature sensors.

14.3.1 Room sensors (B11, B12, B13*, B14*)

Room sensor cable connection:

(B11) Room sensor 1, Relay board A2

Alarm output:	pole G17
GND:	pole G18
Input:	pole G19

(B12) Room sensor 2, Relay board A2

Alarm output:	pole G20
GND:	pole G21
Input:	pole G22

(B13) Room sensor 3, Expansion board A3*

Alarm output:	pole X4:19
Input:	pole X4:20
GND:	pole X4:21

(B14) Room sensor 4, Expansion board A3*

Alarm output:	pole X4:22
Input:	pole X4:23
GND:	pole X4:24

Room sensors should be installed at head height in open areas of the property with good air flow and where a representative temperature can be expected (not close to sources of heat or cold). Place sensors at head height. If you are unsure of where to place a sensor, hang it by a loose cable and test different positions.

Connection: 3-core cable, min 0.5 mm², between sensor and control module. The cables are connected as shown in the table above.

On start-up, an alarm is given if the sensor is incorrectly connected. Test the alarm sensor LED by testing the function in the "Advanced/Service/Function Test" menu.

In the control system you can select whether to have the room sensor operational. If the room sensor is deselected, the heating level is controlled by the outdoor sensor/primary flow sensor. The alarm lamp on the room sensor still functions as normal. A room sensor does not, however, need to be installed if the function is deselected.

*Applies to CTC EcoLogic XL/L.

**Only applies to CTC EcoLogic XL.

14.3.2 Outdoor sensor (B15)

The outdoor sensor should be fitted to the outer wall of the house, preferably in a north-northeaster or north-northwester direction. The sensor should be placed out of direct sunlight. However, where this is difficult to achieve it can also be shielded from the sun by a screen. Remember that the sun rises and sets at different points at different times of the year.

The sensor should be placed about three-quarters of the way up the wall so that it senses the correct outdoor temperature and so that it is not affected by a heat source such as a window, infra-heating, air ventilation outlet, etc.

Connection: 2-core cable (1-1.5 mm²) between the sensor and control module.

The sensor is connected to terminal blocks G11 and G12 of the control module on relay board A2. Connect to the outdoor sensor at the arrows.

NB:

- The sensor may be installed max. 30 m from the control unit.
- It is important that the contact in the connections is good.

14.3.3 Indoor sensors

The sensors sense the outgoing temperature to the radiators. Secure the primary flow sensor to the pipe using straps or similar. Most important is the position of the tip of the sensor as this is the part that detects the temperature. The sensor must be insulated to prevent the ambient temperature from affecting the measurement. For optimum function, use contact paste.

(B1) Primary flow sensor 1, Relay board A2

Position: on the primary flow to heating circuit 1.
The sensor is connected to relay board A2 in positions G13 and G14.

(B2) Primary flow sensor 2, Relay board A2

Position: on the primary flow to heating circuit 2 after radiator pump G2.
The sensor is connected to relay board A2 in positions G15 and G16.

(B3) Primary flow sensor 3, Expansion board A3*

Position: on the primary flow to heating circuit 3 after radiator pump G3.
The sensor is connected to expansion board A3 in positions X3:13 and X3:14.

(B4) Primary flow sensor 4, Expansion board A3*

Position: on the primary flow to heating circuit 4 after radiator pump G4.
The sensor is connected to expansion board A3 in positions X2:7 and X2:8.

(B5) Sensor DHW tank, Relay board A2

Position: in a sensor pipe or on the jacket surface in the DHW tank.
The sensor is connected to relay board A2 in positions G63 and G64.

(B6) Sensor buffer tank, Relay board A2

Position: in a sensor pipe or on the jacket surface in the buffer tank.
The sensor is connected to relay board A2 in positions G65 and G66.

(B7) Return sensor heating circuit, Relay board A2

Position: on the return pipe from the heating circuit.
The sensor is connected to relay board A2 in positions G31 and G32.

(B8) Flue gas sensor, Relay board A2

Position: in a sensor pipe or on the flue gas jacket surface on the wood boiler.
The sensor is connected to relay board A2 in positions G35 and G36.

(B9) Sensor, external boiler, Relay board A2

Position: in a sensor pipe or on the jacket surface in the boiler.
The sensor is connected to relay board A2 in positions G61 and G62.

(B10) Sensor, external boiler out, Relay board A2

Position: on the primary flow pipe of the boiler.
The sensor is connected to relay board A2 in positions G71 and G72.

(B30) In to solar collectors, Expansion board A3*

Position: on the return pipe into the solar collectors.
The sensor is connected to expansion board A3 in positions X1:3 and X1:4.

(B31) Out from solar collectors, Expansion board A3*

Position: on the pipe out from the solar collectors.
The sensor is connected to expansion board A3 at positions X1:1 and X1:2.

(B43) External DHW tank sensor, Expansion board A3*

Position: in a sensor pipe or on the jacket surface in the external DHW tank.
The sensor is connected to expansion board A3 in positions X2:9 and X2:10.

(B50) Sensor, pool, Expansion board A3*

Position: on the return pipe between the pool pump and pool.
The sensor is connected to expansion board A3 in positions X3:15 and X3:16.

(B61) Sensor, cooling tank, Expansion board A3*

Position: in the cooling tank.
The sensor is connected to expansion board A3 in positions X3:17 and X3:18.

(B70) Sensor, proportional diverting valve, I/O board A7**

Position: on the outgoing brine pipe.
The sensor is connected to I/O board A7 in position (X3-A)-1 and (X3-B)-2.

**Applies to CTC EcoLogic XL/L.*

***Only applies to CTC EcoLogic XL.*

(B73) Return sensor, active cooling CTC EcoLogic, Expansion board A3*

Position: on the return pipe from heating circuit 1.
The sensor is connected to expansion board A3 in positions X3:11 and X3:12.

(B75) Sensor, exchanger cooling tank, I/O board A7**

Position: on the pipe between the exchanger and the cooling tank.
The sensor is connected to I/O board A7 in position (X1A-C)-3 and (X1A-D)-4.

(B77) Sensor, cooling tank upper, I/O board A7**

Position: in the cooling tank.
The sensor is connected to I/O board A7 in position (X1B-A)-1 och (X1B-B)-2.

(B79) Sensor, DHW tank upper, I/O board A7**

Position: in a sensor pipe or on the jacket surface in the DHW tank.
The sensor is connected to I/O board A7 in position (X2-C)-3 och (X2-D)-4.

(B80) Sensor, buffer tank upper, I/O board A7**

Position: in a sensor pipe or on the jacket surface in the buffer tank.
The sensor is connected to I/O board A7 in position (X2-E)-5 och (X2-F)-6.

14.3.4 Settings to be carried out by the installation electrician

The following settings shall be made by the installation electrician after installation:

- Select main fuse size.
- Select power limitation.
- Check room sensor connection.
- Check that the sensors connected indicate reasonable values.
- Carry out the checks below.

14.3.5 Check room sensor connection

1. Scroll down and select the "LED room sensor" option in the "Advanced/Service/Function test/Heating circuit" menu.
2. Select "On". Check that the room sensor LED lights up. If not, check the cables and connection.
3. Select "Off". If the LED goes off, the check is complete.

14.3.6 Checking connected sensors

If any sensor is incorrectly connected, a message will appear on the display, e.g. "Alarm sensor out". If multiple sensors are incorrectly connected, the different alarms are displayed on different rows. If no alarm is displayed, the sensors are connected correctly. Note the alarm function of the room sensor (LED) cannot be detected on the display. It must be checked on the room sensor.

14.3.7 Pressure/Level switch

In some cases, extra protection is required due to local requirements or provisions. For example, the requirement in some areas is for the system to be installed within a water catchment area.

The pressure/level switch connects to K22/K23/K24/K25 and is then defined under the "Advanced/Define/Heat Pump" menu. If there is a leak, the compressor and brine pump stops and the "Flow/level switch" alarm appears on the display.

**Applies to CTC EcoLogic XL/L.*

***Only applies to CTC EcoLogic XL.*

15. Wiring diagram

15.1 Relay board A2

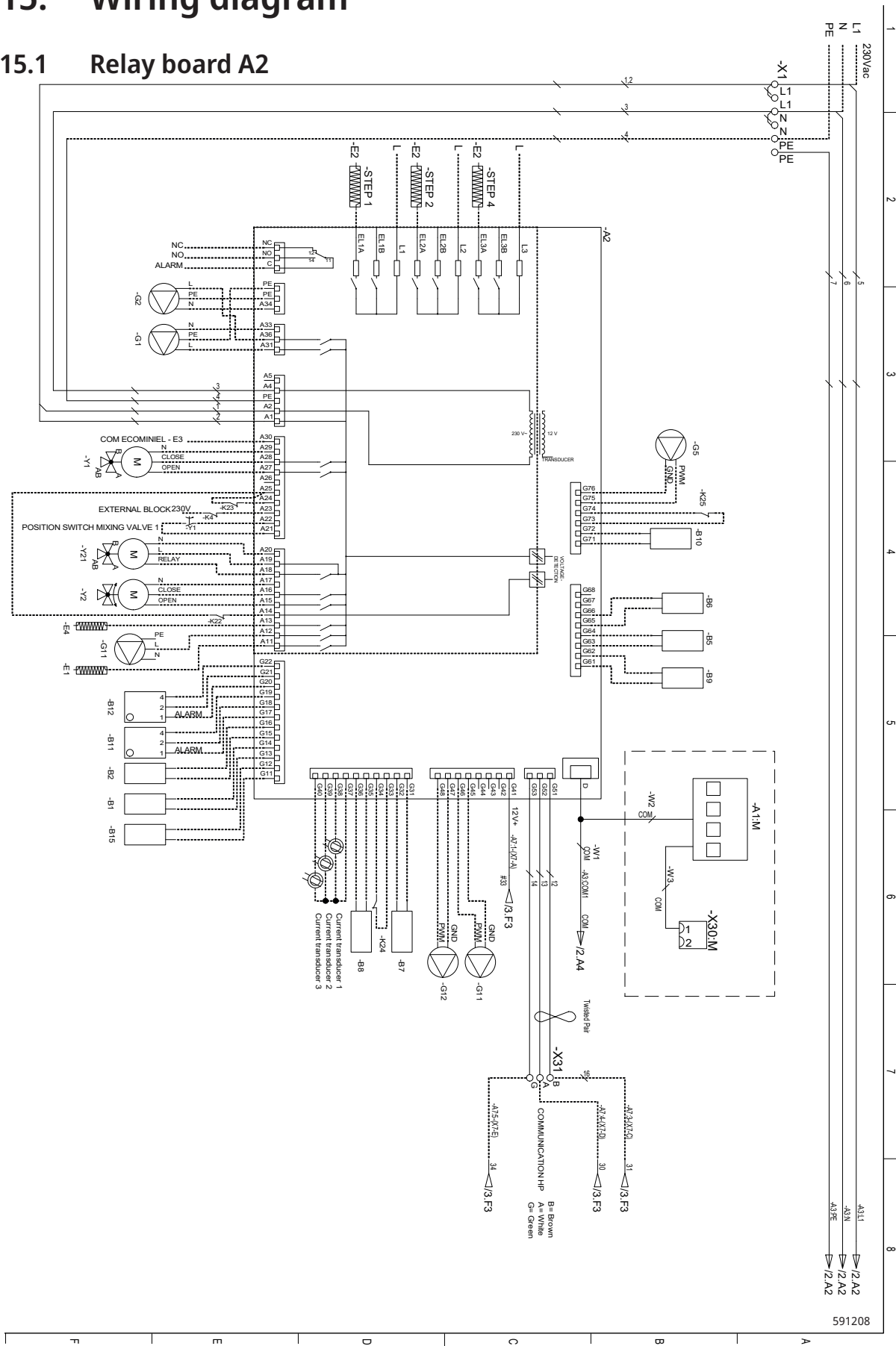

15.2 Expansion board A3

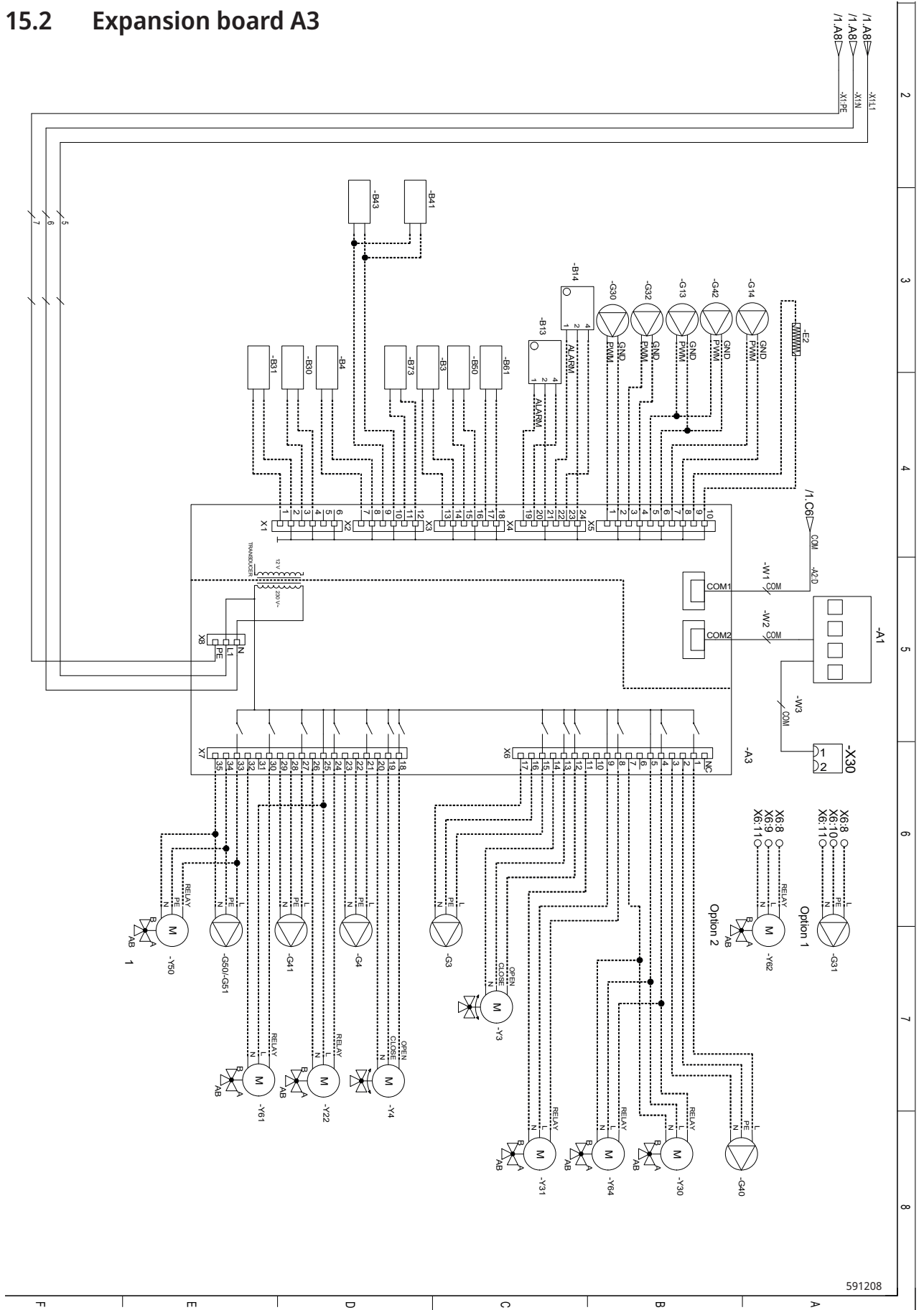

15.3 I/O board A7

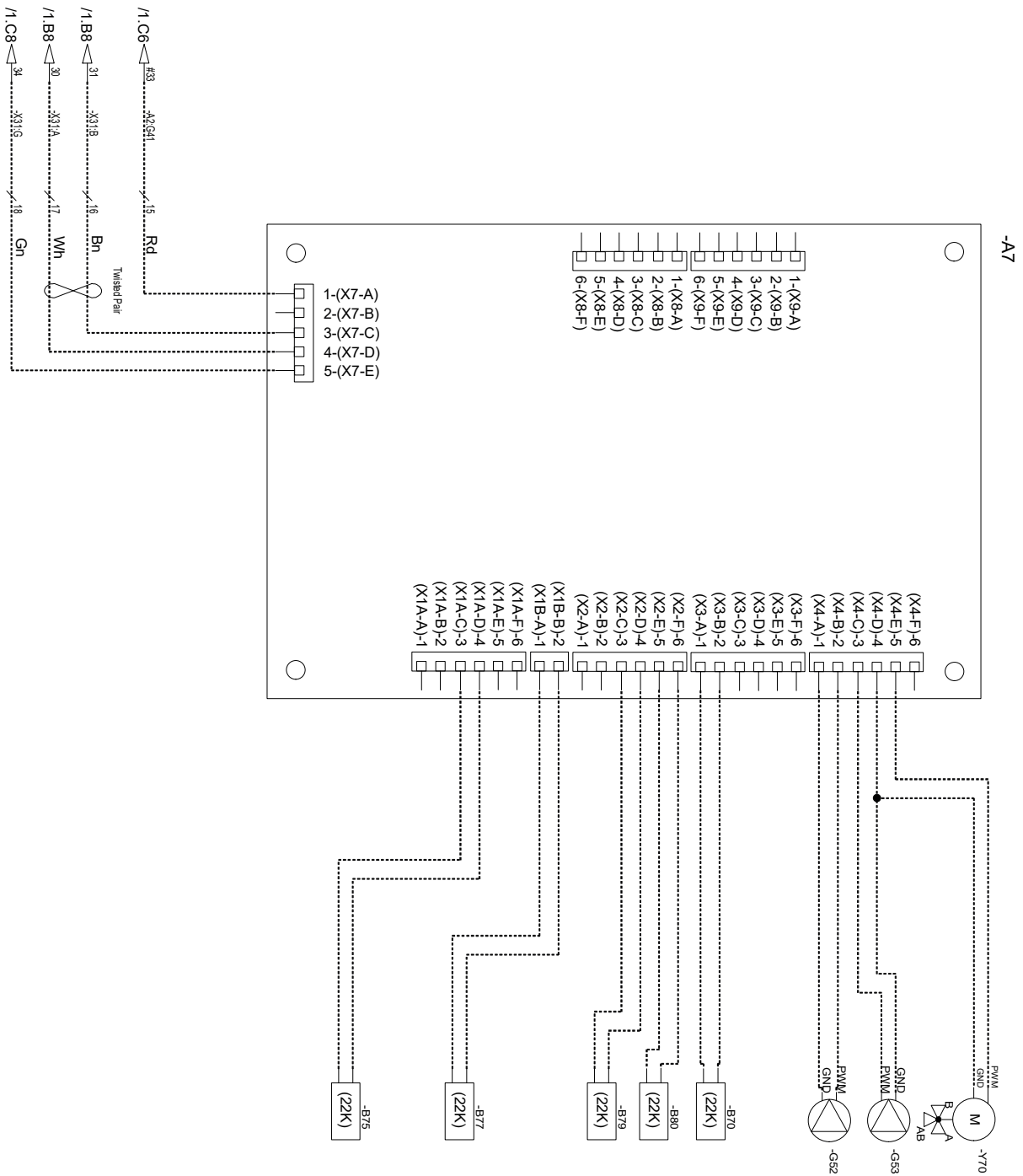

591208

15.4 Connection table for electrical components

This table shows the connections for components for the CTC EcoLogic relay board A2, expansion board A3 or I/O board A7, (see also the wiring diagram).

Connection	Designation	Option	Board	Terminal block	Cable
E1	Additional heat		A2 X1 X1	A11 N PE	Relay output
E2	Additional heat, 0-3 step/0-7 step	X	A2 A2 A2 A2 A2 A2 A2 X1 X1	EL1A EL1B EL1A+EL1B EL2A EL1A+EL2A EL1B+EL2A EL1A+EL1B+EL2A N PE	
E2*	Additional heat, 0-10V analogue	X	A3 A3	X5:9 X5:10	
E3	Additional heat, EcoMiniEI 0-3 step		A2 X1 X1	A30 N PE	Comm 230V
E4	Additional heat, DHW		A2 X1 X1	A13 N PE	Relay output
G1	Radiator pump 1		A2 A2 A2	A31 PE A33	Phase PE N
G2	Radiator pump 2		A2 A2 A2	A36 PE A34	Phase PE N
G3*	Radiator pump 3	X	A3 A3 A3	X6:15 X6:16 X6:17	Phase PE N
G4*	Radiator pump 4	X	A3 A3 A3	X7:21 X7:22 X7:23	Phase PE N
G5	Circulation pump, DHW heat exchanger		A2 A2	G75 G76	PWM+ GND
G11	Charge pump HP1		A2 A2 A2	G45 G46 A12	GND PWM+ Relay output
G12	Charge pump HP2		A2 A2	G47 G48	GND PWM+
G13*	Charge pump HP3	X	A3 A3	X5:5 X5:6	PWM+ GND
G14*	Charge pump HP4	X	A3 A3	X5:7 X5:8	PWM+ GND
G30*	Circulation pump, solar collectors	X	A3 A3	X5:1 X5:2	PWM+ GND
G31*	Charge pump, recharge borehole	X	A3 A3 A3	X6:8 X6:10 X6:11	Phase PE N
G32*	Pump, heat exchanger solar collectors	X	A3 A3	X5:3 X5:4	PWM+ GND

*Applies to CTC EcoLogic XL/L.

Connection	Designation	Option	Board	Terminal block	Cable
G40*	Circulation pump, DHW	X	A3 A3 A3	X6:1 X6:2 X6:3	Phase PE N
G41*	Charge pump, external DHW tank	X	A3 A3 A3	X7:27 X7:28 X7:29	Phase PE N
G42*	Circulation pump, external buffer tank	X	A3 A3	X5:5 X5:6	PWM+ GND
G50/G51*	Pumps, pool	X	A3 A3 A3	X7:33 X7:34 X7:35	Phase PE N
G52**	Pump, brine heat dumping	X	A7	(X4-A)-1 (X4-B)-2	GND PWM+
G53**	Charge pump, heat exchanger cooling tank	X	A7	(X4-C)-3 (X4-D)-4	PWM+ GND
K22	Remote control		A2	A14	***
K22/K23	Remote control		A2	A25	***
K23	Remote control		A2	A24	***
K24	Remote control		A2	G33	***
K24	Remote control		A2	G34	***
K25	Remote control		A2	G73	***
K25	Remote control		A2	G74	***
Y1	Mixing valve 1		A2 A2 A2 A2 A2	A27 A28 A29 A22 A21	Open Close N Limit position Limit position
Y2	Mixing valve 2		A2 A2 A2	A15 A16 A17	Open Close N
Y3*	Mixing valve 3	X	A3 A3 A3	X6:12 X6:13 X6:14	Open Close N
Y4*	Mixing valve 4	X	A3 A3 A3	X7:18 X7:19 X7:20	Open Close N
Y21	3-way valve HP1		A2 A2 A2	A18 A19 A20	Relay output Phase N
Y22*	3-way valve HP2		A3 A3 A3	X7:24 X7:25 X7:26	Relay output Phase N
Y30*	Sun, 3-way valve DHW	X	A3 A3 A3	X6:4 X6:5 X6:7	Control voltage Phase N
Y31*	3-way valve, sun	X	A3 A3 A3	X6:8 X6:9 X6:11	Open to borehole Open to tank N
Y50*	3-way valve, pool	X	A3 A3 A3	X7:33 X7:34 X7:35	Phase PE N
Y61*	Diverting valve, active cooling	X	A3 A3 A3	X7:30 X7:32 X7:25	Relay output N Phase

*Applies to CTC EcoLogic XL/L.

**Applies only to CTC EcoLogic XL.

***Connection according to description of remote control functions.

Connection	Designation	Option	Board	Terminal block	Cable
Y62*	3-way valve, active cooling demand relay	X	A3 A3 A3	X6:8 X6:9 X6:11	Relay output Phase N
Y64*	Diverting valve, heat dumping	X	A3 A3 A3	X6:4 X6:5 X6:7	Relay output Phase N
Y70**	Proportional diverting valve cooling	X	A7 A7	(X4-D)-4 (X4-E)-5	GND PWM+
B1	Primary flow sensor 1		A2 A2	G13 G14	
B2	Primary flow sensor 2		A2 A2	G15 G16	
B3*	Primary flow sensor 3	X	A3 A3	X3:13 X3:14	
B4*	Primary flow sensor 4	X	A3 A3	X2:7 X2:8	
B5	Sensor, DHW tank		A2 A2	G63 G64	
B6	Sensor, buffer tank		A2 A2	G65 G66	
B7	Return sensor, heating circuit		A2 A2	G31 G32	
B8	Sensor, flue gas		A2 A2	G35 G36	
B9	Sensor, external boiler		A2 A2	G61 G62	
B10	Sensor, external boiler out		A2 A2	G71 G72	
B11	Room sensor 1		A2 A2 A2	G17 G18 G19	
B12	Room sensor 2		A2 A2 A2	G20 G21 G22	
B13*	Room sensor 3	X	A3 A3 A3	X4:19 X4:20 X4:21	
B14*	Room sensor 4	X	A3 A3 A3	X4:22 X4:23 X4:24	
B15	Outdoor sensor		A2 A2	G11 G12	
B30*	Sensor, solar collectors in	X	A3 A3	X1:3 X1:4	
B31*	Sensor, solar collectors out	X	A3 A3	X1:1 X1:2	
B41*	Sensor, external buffer tank upper	X	A3 A3	X2:9 X2:10	
B43*	Sensor, external DHW tank	X	A3 A3	X2:9 X2:10	
B50*	Sensor, pool	X	A3 A3	X3:15 X3:16	
B61	Sensor, cooling tank	X	A3 A3	X3:17 X3:18	

*Applies to CTC EcoLogic XL/L.

**Applies only to CTC EcoLogic XL.

Connection	Designation	Option	Board	Terminal block	Cable
B70**	Sensor, proportional mixing valve	X	A7 A7	(X3-A)-1 (X3-B)-2	
B73*	Return sensor, active cooling	X	A3	X2:11 X2:12	
B75**	Sensor, heat exchanger cooling tank	X	A7	(X1A-C)-3 (X1A-D)-4	
B77**	Sensor, cooling tank upper	X	A7	(X1B-A)-1 (X1B-B)-2	
B79**	Sensor, DHW tank upper	X	A7	(X2-C)-3 (X2-D)-4	
B80**	Sensor, buffer tank upper	X	A7	(X2-E)-5 (X2-F)-6	
HP1	Heat pump 1				
HP2	Heat pump 2				
HP3	Heat pump 3	X			
HP4	Heat pump 4	X			
HP5	Heat pump 5	X			
HP6	Heat pump 6	X			
HP7	Heat pump 7	X			
HP8	Heat pump 8	X			
HP9	Heat pump 9	X			
HP10	Heat pump 10	X			

*Applies to CTC EcoLogic XL/L.

**Applies only to CTC EcoLogic XL.

15.5 Resistances for sensors

NTC 3.3K		NTC 22K		NTC 150	
Temperature °C	Resistance Ω	Temperature °C	Resistance Ω	Temperature °C	Resistance Ω
300	64	130	800	70	32
290	74	125	906	65	37
280	85	120	1027	60	43
270	98	115	1167	55	51
260	113	110	1330	50	60
250	132	105	1522	45	72
240	168	100	1746	40	85
230	183	95	2010	35	102
220	217	90	2320	30	123
210	259	85	2690	25	150
200	312	80	3130	20	182
190	379	75	3650	15	224
180	463	70	4280	10	276
170	571	65	5045	5	342
160	710	60	5960	0	428
150	892	55	7080	-5	538
140	1132	50	8450	-10	681
130	1452	45	10130	-15	868
120	1885	40	12200	-20	1115
110	2477	35	14770	-25	1443
100	3300	30	18000	-30	1883
90	4459	25	22000	-35	2478
80	6119	20	27100	-40	3289
70	8741	15	33540		
60	12140	10	41800		
50	17598	5	52400		
40	26064				
30	39517				
20	61465				

PT1000

Temperature °C	Resistance Ω	Temperature °C	Resistance Ω
-10	960	60	1232
0	1000	70	1271
10	1039	80	1309
20	1077	90	1347
30	1116	100	1385
40	1155	120	1461
50	1194	140	1535

16. Installation, Communication

In order to define Web and App, an ethernet cable needs to be connected.

! Installation must be carried out by a qualified professional in accordance with applicable regulations.

1. Connect the ethernet cable to the ethernet connector below the unit.

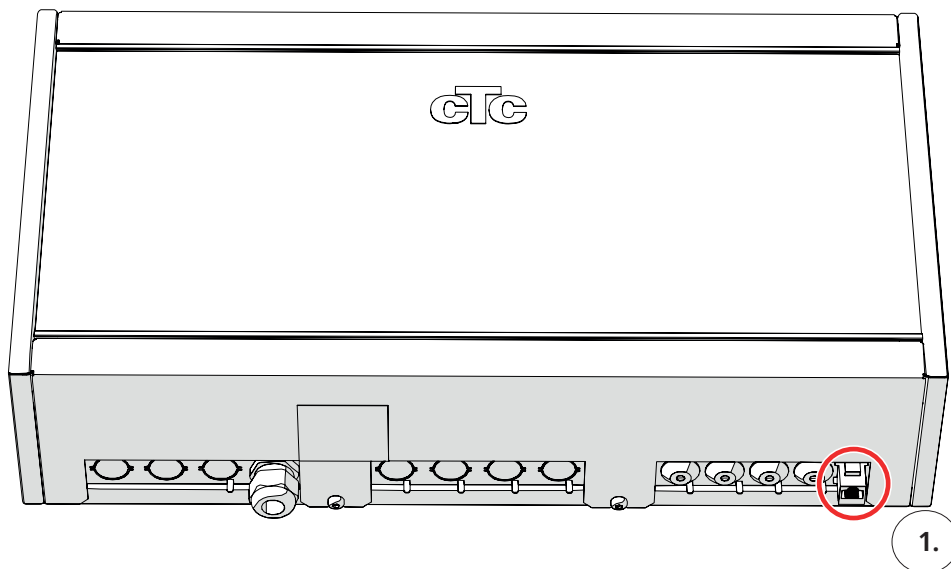

2. Connect ethernet cable to network port or router.

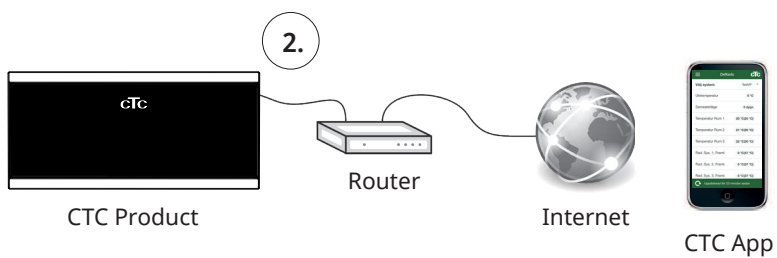

To enable connectivity, refer to the “Advanced/ Define/Communication” and “Advanced/Settings/ Communication” chapters.



16.1 Remote - Screen Mirroring

- Connect the ethernet cable, see previous page.
- Advanced/Define/Communication/Web – Yes.
Permits the product to connect with unencrypted web traffic on local area networks. Internet router and firewall required.
- Advanced/i – Scan the QR code with a tablet or smartphone. 
- Save as a favourite/icon on your mobile phone/tablet/computer. When your mobile phone/tablet is connected to the local network, the touch screen on the product can be accessed just as if you were using the product's display.
- In the app: scan QR code or enter address
"http://ctcXXXX/main.htm".
(XXXX = the last four digits of the display serial number, for example S/N 888800000040 = "http://ctc0040/main.htm").
In case of problems: click the link to update to the device's current IP no.

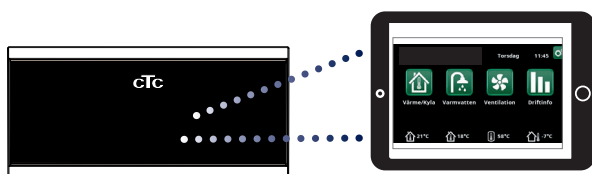

Tablet/Smartphone/PC as a touchscreen for local area network
"Advanced/Define/Communication/Web" – "Yes".

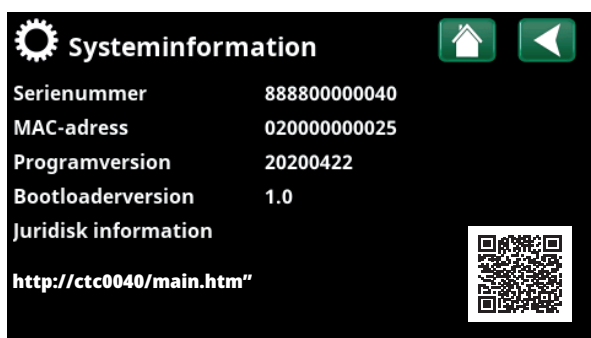

16.2 myUplink



With myUplink you can conveniently monitor and change the settings of your heat pump and your heating system from your mobile phone. Change the desired indoor temperature, hot water settings or activate the vacation mode remotely via myUplink. The app shows easy-to-understand graphics in which you can follow the temperatures and the performance of the heat pump. myUplink also receives push notifications when your heat pump alarms.

App installation

- Download myUplink from AppStore or Google Play.
- Create an account.
- Add system.

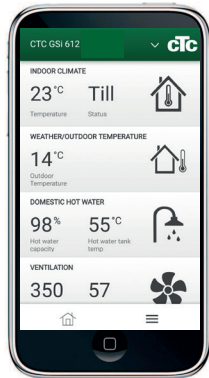

Define myUplink

Define myUplink in the display menu "Advanced/Define/Communication".

myUplink

No (Yes/No)

Select "Yes" to connect the main product to the myUplink app.

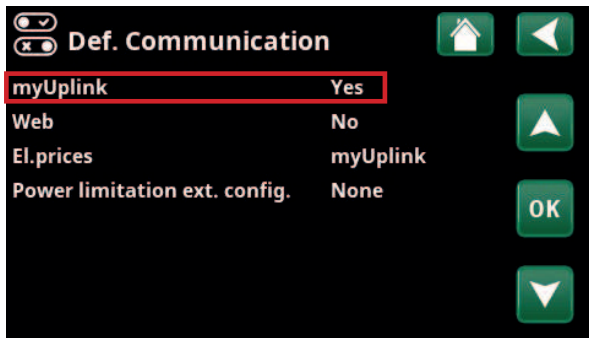

Connect myUplink

The display menu "Advanced/Settings/Communication/myUplink" has lines highlighted in grey until the display is connected to myUplink.

When the connection is established, the top line "Get connection string" lights up.

When the time has expired, the connection string disappears from the display and you can request a new string by pressing "Get connection string" in the display.

Connect the system to the myUplink app by scanning the QR code in the display menu, or enter the connection information manually. See section "Add System".



Add System

Connect your system to your account by clicking the down arrow next to the logo in the upper right corner of the myUplink app. Then select "Add System" *.

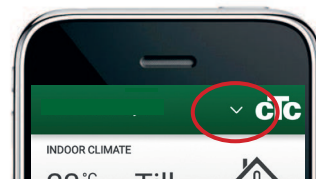

Scan QR code

Select "Scan the QR code" and then scan the QR code in the display (Advanced/Settings/Communication/myUplink). Check the data generated and press "Add".

Enter manually

If the QR code is missing or if the QR code can not be read; first press "Enter manually" and then "Enter connection details".

- Enter the serial number and connection string and press "Continue".
- Enter the name of the system (eg property address).
- Enter the postal code where the system is located.
- Select the country where the system is located.

Add user

First, to create an account, the app must be downloaded and an account created before the user can be added.

Multiple users can be connected to the same system. As an administrator, you can add users so that they can monitor your system. Only existing accounts can be added. These are categorised according to the permissions "Monitor" and "Control".

i The website <https://myuplink.com> can also be used to control and monitor the system.

**To establish a new connection, previous users must be deleted.*

17. First start

CTC EcoLogic can be started without a fitted room sensor, since the set curve then regulates the heating. Deselect the room sensor for the respective heating circuit in the "Advanced/Settings" menu. The sensors can, however, always be fitted for the alarm LED function.

Before first start

1. Check that the system is filled with water, purged and has the correct pressure, and that there is no leakage. Air in the system (poor circulation) can, for example, mean that the heat pump is tripped by its high pressure protection.
2. Check that all the valves in the system are correctly connected and set.
3. Check that all electrical cables and sensors are correctly installed and connected. See section "Electrical installation".
4. Check that the unit is correctly fused (10A group fuse).
5. Check that the heat pump is switched on.
6. If there is already a boiler in place, check that its temperature is set at normal boiler temperature, for example, 70°C.
7. Check that the control box of the heat pumps is set to HP1, HP2, HP3, etc. Refer to the heat pump instructions.

First start

Turn on the power with the safety switch. The display will switch on. The heat pump now asks the following:

1. Select the language and press "OK".
2. Confirm that the system is filled with water by pressing "OK".
3. Select CTC EcoLogic System Type (1, 2, 3, 4, 5, 6).
4. Indicate whether the DHW tank is connected.
5. Select the option permitting the compressor to operate (if the collector system is ready). When the compressor is started for the first time, a check is automatically carried out to ensure that it is running in the correct direction. An error message is shown on the display if it is rotating in the wrong direction. Switch any two phases to change the direction of rotation. Use your hand to feel that the discharge pipe immediately becomes warm when the compressor starts but remember that the pipe may be hot!
6. Select "Brine pump on": 10 days for operation over ten days.
7. Specify "Max primary flow °C" for heating circuit 1.
8. Specify "Inclination °C" for heating circuit 1.
9. Specify the "Adjustment" for heating circuit 1.
10. If the primary flow sensor for heating circuit 2 is installed, repeat steps 7 to 9 for heating circuit 2.

The heat pump then starts and the start page appears.

Refer to the "Display settings" chapter for more information.

 Save these settings in the "Advanced/Settings/Save Settings" menu.

 If heating circuits 3* and 4* are to be used, they must be activated in the "Advanced/Define System/Heating Circuit 3/4" menu.

*Applies to CTC EcoLogic XL/L.



CTC AB
Box 309 SE-341 26 Ljungby
+46 372 88 000
info@ctc.se
www.ctc.se