



Made in Småland

CTC EcoAir C100

Efficient and sustainable heating and cooling.
Modulating air-to-water heat pumps, 6-16 kW.
Models: C106, C108, C112 and C116.



www.ctc.no

A cost-effective air-to-water heat pump series, with modulating technology and climate-friendly R290 refrigerant, combining efficiency, performance, and sustainability.

Heating and cooling

The CTC EcoAir C100 is a range of variable speed air-to-water heat pumps that deliver efficient heating and cooling. Since it uses outdoor air as its energy source, installation is simple — no boreholes or underground piping required. The series is available in four sizes: C106, C108, C110 and C116.

A smart choice for year-round comfort

CTC EcoAir C100 is a smart choice for those looking for an energy-efficient, climate friendly and future-proof solution for both heating and cooling. Simple to install, easy to control and built to deliver year-round comfort.

Flexible installation

The CTC EcoAir C100 is designed for easy placement — whether mounted on a wall bracket or installed on a ground stand. Its exceptionally slim and minimalist design not only blends into most environments, but also makes it ideal for homes and plots where space is limited or aesthetics matter.

Air-to-water heat pump: how it works

An air-to-water heat pump extracts energy from the outdoor air. This energy is converted into heat, which is used to heat water in a hydronic heating system. When the temperature drops outside, down to -25 °C, the heat pump works to supply both heat and hot water. On hot days, it can be used to cool the home instead. This makes the CTC EcoAir C100 a complete solution for year-round comfort.

Climate caring technology

The heat pump uses the refrigerant R290, a climate-friendly alternative with an extremely low global warming potential (GWP) of only 0.02. By choosing a heat pump with R290, you are making a conscious choice for a greener future.

Flexible control and system integration

The CTC EcoAir C100 is controlled via indoor module or controller. These units monitor and control not only the heat pump, but also the peak heat, buffer tanks, solar energy, swimming pool and

other parts of the heating system. Install the CTC EcoAir C100 together with a CTC indoor module and you have a complete heating, cooling and hot water solution.

Connected and ready for the future

All CTC controllers have internet connection as standard. With the myUplink app, you can control and monitor your system directly from your mobile phone - adjust temperature, receive operating alarms and view real-time status. The system is also smart home ready (e.g. Alexa, Google Home) and Smartgrid compatible.

CTC – Experience you can rely on

CTC is a Swedish brand with over a century of experience in heating technology. When you choose a product from CTC you're getting solid warranties, expert service, and support from people who know the system inside and out.

Technical data 400V		C108	C112	C116
CTC no.		591002001	591004001	591006001
Weight (packaged weight)	kg	106 (124)	123 (142)	150 (173)
Dimensions (depth x width x height)	mm	488x1204x892	488x1204x1103	488x1204x1397
Specified output max: W35 & A +12/+7/+2/-2/-7/-15 (EN14511)	kW	11,52/ 9,47/ 8,91/ 8,09/ 7,48/ 6,55	13,52/ 12,46/ 10,10/ 9,97/ 9,19/ 7,43	17,97/ 16,74/ 12,87/ 12,88/ 11,40/ 9,59
Input power max: W35 & A +12/+7/+2/-2/-7/-15 (EN14511)	kW	2,60/ 2,59/ 2,76/ 2,79/ 2,91/ 2,90	2,89/ 3,06/ 3,05/ 3,27/ 3,22/ 3,08	3,69/ 3,99/ 4,02/ 4,28/ 4,19/ 4,03
Cooling capacity max: A35 & W18 / W7 (EN14511)	kW	6,81 / 5,19	8,81 / 6,71	10,88 / 8,45
EER max: A35 & W18 / W7 (EN14511)		3,04 / 2,27	5,49 / 4,03	5,03 / 3,73
Sound power L _{WA} W35/A7 (EN 12102)	dB(A)	50	52	52
Sound pressure L _{PA} 5 m	dB(A)	31	33	33
Sound pressure L _{PA} 10 m	dB(A)	25	27	27
Electrical Data, connection		380-415V 3N~ 50Hz		
Rated current (fuse)	A	5 (6)	6 (10)	9 (10)
Ingress protection class (IP)		IP 24		
Airflow: max	m ³ /h	3300	5600	6100
Refrigerant quantity (R290, GWP 0.02)	kg	0,8	1,1	1,6
CO ₂ - equivalent	tonnes	0,000016	0,000022	0,000032
SCOP cold climate: W35/W55 (EN14825, Pdesignh)		4,45 / 3,49	4,29 / 3,42	4,49 / 3,55
SCOP average climate: W35/W55 (EN14825, Pdesignh)		4,78 / 3,78	4,78 / 3,82	5,15 / 3,97
SCOP warm climate: W35/W55 (EN14825, Pdesignh)		6,60 / 4,75	6,79 / 4,96	6,67 / 5,00
Package efficiency class: W35/W55 (A+++ to G) *		A+++/ A+++	A+++/ A+++	A+++/ A+++
Energy efficiency class: W35/W55 (A+++ to D)		A+++/ A++	A+++/ A+++	A+++/ A+++

* The reported data applies to use with the CTC EcoLogic M control unit.

Energy labels and data sheets can be downloaded from www.ctc-heating.com/Ecodesign.



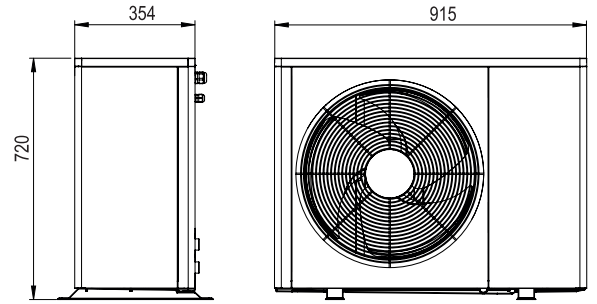
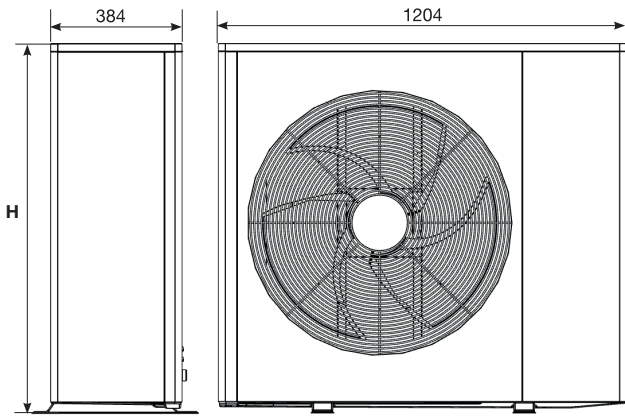

MODEL	H
EcoAir C108	892
EcoAir C112	1103
EcoAir C116	1397

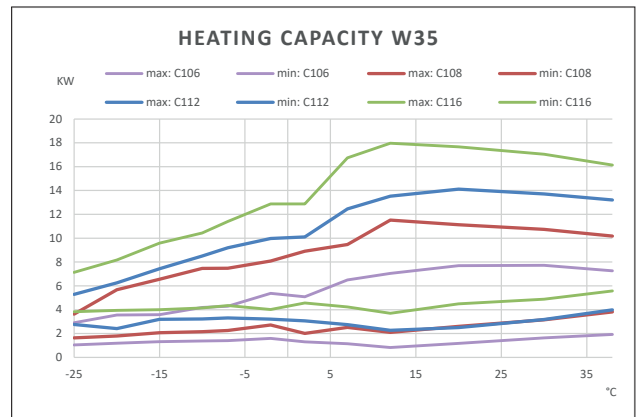
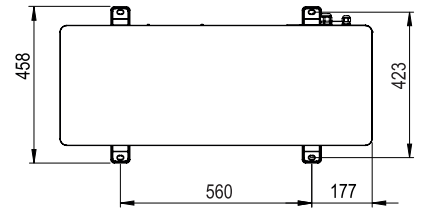
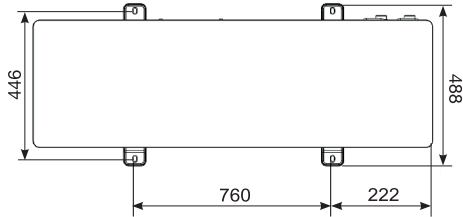

Delivery includes:

Heat pump with factory-fitted power cable, 1.8 m .

Packaging includes:

Filter ball valve: G1', condensation drain adapter, jumper bar, vibration dampers and manual.

Technical data 230V		C106	C108	C112	C116
CTC no.		591000001	591001001	591003001	591005001
Weight (packaged weight)	kg	70 (82)	98 (116)	115 (134)	142 (165)
Dimensions (depth x width x height)	mm	458x915x720	488x1204x892	488x1204x1103	488x1204x1397
Specified output max: W35 & A +12/+7/+2/-7/-15 (EN14511)	kW	7,05/ 6,50/ 5,08/ 5,37/ 4,29/ 3,59	11,52/ 9,47/ 8,91/ 8,09/ 7,48/ 6,55	13,52/ 12,46/ 10,10/ 9,97/ 9,19/ 7,43	17,97/ 16,74/ 12,87/ 12,88/ 11,40/ 9,59
Input power max: W35 & A +12/+7/+2/-7/-15 (EN14511)	kW	1,37/ 1,48/ 1,60/ 1,87/ 1,70/ 1,58	2,60/ 2,59/ 2,76/ 2,79/ 2,91/ 2,90	2,89/ 3,06/ 3,05/ 3,27/ 3,22/ 3,08	3,69/ 3,99/ 4,02/ 4,28/ 4,19/ 4,03
Cooling capacity max: A35 & W18 / W7 (EN14511)	kW	6,81 / 5,19	6,81 / 5,19	8,81 / 6,71	10,88 / 8,45
EER max: A35 & W18 / W7 (EN14511)		3,04 / 2,27	3,04 / 2,27	5,49 / 4,03	5,03 / 3,73
Sound power L _{WA} W35/A7 (EN 12102)	dB(A)	48	50	52	52
Sound pressure L _{PA} 5 m	dB(A)	29	31	33	33
Sound pressure L _{PA} 10 m	dB(A)	23	25	27	27
Electrical Data, connection		220-240V ~ 50Hz			
Rated current (fuse)	A	10 (13)	12,5 (16)	16 (20)	22 (25)
Ingress protection class (IP)		IP 24			
Airflow: max	m ³ /h	2500	3300	5600	6100
Refrigerant quantity (R290, GWP 0.02)	kg	0,5	0,8	1,1	1,6
CO ₂ - equivalent	tonnes	0,000010	0,000016	0,000022	0,000032
SCOP cold climate: W35/W55 (EN14825, Pdesignh)		4,14 / 3,31	4,45 / 3,49	4,29 / 3,42	4,49 / 3,55
SCOP average climate: W35/W55 (EN14825, Pdesignh)		4,75 / 3,37	4,78 / 3,78	4,78 / 3,82	5,15 / 3,97
SCOP warm climate: W35/W55 (EN14825, Pdesignh)		6,22 / 3,92	6,60 / 4,75	6,79 / 4,96	6,67 / 5,00
Package efficiency class: W35/W55 (A+++ to G) *		A+++ / A++	A+++ / A+++	A+++ / A+++	A+++ / A+++
Energy efficiency class: W35/W55 (A+++ to D)		A+++ / A++	A+++ / A++	A+++ / A+++	A+++ / A+++

Compatible control units

– refer to individual product sheets for more detailed information.



CTC EcoZenith
i360 L/H

CTC EcoLogic L/M

CTC EcoZenith
i255 L/H

Smart accessories

– supplement and simplify.

CTC Installation Kit C100	For frost-protected outdoor installations and communication with control unit	591870301
CTC Charge Pump 25/7.0-130	7.0 m A-class PWM. Suitable for 6-8 kW heat pumps	587477303
CTC Charge Pump 25/7.5-130	7.5 m A-class PWM. Suitable for 10-12 kW heat pumps	587477302
CTC Charge Pump 25/8.5-130	8.5 m A-class PWM. Suitable for 14-22 kW heat pumps	587477301
CTC Condensation drain EA 1m	Insulated condensate drain hose with heating cable 1 m	590955301
CTC Condensation drain EA 3m	Insulated condensate drain hose with heating cable 3 m	590955302
CTC Condensation drain EA 6m	Insulated condensate drain hose with heating cable 6 m	590955303
CTC Ground stand C100	Sturdy stand for outdoor unit	591753301
CTC Wall bracket C100	Wall mounting kit for outdoor unit	591752301
CTC Safety valve 2,5 bar	Replacement valve for 3 bar heating systems	591871301
CTC Safety valve 3,0 bar	Replacement valve for >3,5 bar heating systems	591872301
CTC Heating Cable	Frost protection kit for condensate pipe with 5 m cable	586685401
Communication cable 15 m	Shielded cable for communication via Modbus	591973301

Find more accessories at ctc-heating.com

info@ctc.se +46 372 88 000 P.O Box 309 SE-341 26 Ljungby Sweden