



Installation and Maintenance Manual

CTC Module 300/400

Modell 400L and 300/400 E15



Translation of the original instructions.
Keep for future use.
Read carefully before use.

Table of contents

1.	Congratulations on your new product.....	3
2.	Safety instructions.....	4
3.	Checklist.....	5
4.	Serial number.....	6
5.	Important to remember!	7
5.1	Transportation.....	7
5.2	Positioning.....	7
5.3	Recycling.....	7
5.4	After commissioning.....	7
6.	System components	8
7.	Technical data / Energy labelling	9
8.	Pipe installation	12
9.	System options	13
9.1	System 1.....	13
9.2	System 2.....	15
9.3	Flange couplings.....	17
9.4	Example of installation.....	17
10.	Recommendations and design	18
11.	Electrical installation	20
11.1	Wiring diagram, immersion heater.....	21
12.	Commissioning	22
13.	Operation and maintenance	23
14.	Thermostat for immersion heater	23
15.	Troubleshooting and actions	24

Product:	Serial no:
Piping installation performed by:	Name:
Date:	Tel. no.:

No liability is accepted for any misprints. We reserve the right to make design changes.

Software update



software.ctc.se

EN

For more information on updated functions and downloading the latest software, see the website "software.ctc.se".

1. Congratulations on your new product



You have just bought a CTC Module heater system, which we hope you will be very pleased with. On the following pages, you will find information on how the system must be installed and maintained.

Save this manual containing the installation and maintenance instructions. If properly maintained, you will be able to enjoy the use of your system for many years. This manual provides all the information you will need.

The complete system for hot tap water

CTC Module is a complete heater system intended for hot tap water where there is high demand for hot water.

The system consists of 282/380 litre tanks that can easily be connected in series/parallel to create desired capacity.

Two types of tanks are available; with or without 7.5 kW inbuilt immersion heater, respectively. For example, a system consisting of 1x CTC Module 400 E15 power module (inbuilt immersion heater) and 3x 400 L storage tanks.

The system is suitable for use together with heat pumps, solar collectors or other external heat sources. A modified heat exchanger transfers the heat to the hot water in the tanks.

CTC Module 300/400 E15

CTC Module 300/400 E15 is a power module. On its own, the immersion heater is capable of, for example, heating tap water in the tank system, adjusting the Legionella prevention function in a heat pump system, or controlling additional heating when extra capacity is required.

CTC Module 400 L

CTC Module 400 L are storage tanks for hot tap water. Any number of tanks can be connected depending on your hot water needs.

NOTE! This installation manual provides information on technical data, operation, installation etc. Local or national rules for the relevant country must be observed.

To benefit from our warranty and CTC guarantee, the installation certificate must be registered online at ctc.se within 6 months of the purchase date.

2. Safety instructions



Turn off the power with an omnipolar switch before doing any work on the product.



The product must be connected to a protective earth.



Any work on the product should be done by authorised personnel only.

Safety valve for boiler/system and hot tap water to be checked regularly.

This product can be used by children from the age of eight years and above, and by people with reduced physical, sensory or mental ability or lack of experience or knowledge, if they have been taught, either with supervision or with the instructions provided, how to use the product safely and understand the risks involved. Children should not play with the product. Cleaning and maintenance should not be carried out by children without supervision.

As extra security, the product can be anchored in a wall.



The product is classified as IP44. The product must not be rinsed with water.



When handling the product with a hoist ring or similar device, make sure that the lifting equipment, eyebolts and other parts are not damaged. Never stand under the hoisted product.



If these instructions are not followed when installing, operating and maintaining the system, CTC's commitment under the applicable warranty terms is not binding.



Information in this type of box [!] is particularly important for correctly installing and using the product. användning av produkten.

3. Checklist

The checklist must always be completed by the installer

- In the event of servicing, this document may need to be provided.
- Installation must always be carried out according to the Installation and Maintenance manual.
- Installation must always be carried out according to professional standards.

Following installation, the unit must be inspected and functional checks performed as indicated below:

Pipe installation

- The system filled, positioned and adjusted according to professional standards and the instructions.
- Product placed to facilitate service.
- Pumps, valves etc. sized according to required flows.
- System tested for leakage and correctly sealed.
- Bleeding performed (subsequent bleeding may be necessary).
- Safety equipment fitted and inspected/functionally tested.
- Overflow pipes from safety valves routed to floor drain.
- Tank system flushed with cold freshwater as per these instructions.
- Secondary visit to inspect seals and check that system bleeding performed.

Electrical installation

- Safety switch installed.
- Cable routing correct according to applicable regulations.
- Correct fuse installed (group fuse).



If these instructions are not followed when installing, operating and maintaining the system, CTC's commitment under the applicable warranty terms is not binding.

Customer information (adapted to the relevant installation)



- Start-up with customer and installer.
- Review of heating unit connected to the tank system.
- Installation and Maintenance Manual given to the customer.
- Check and filling, heating circuit.
- Fine-tuning information, valve settings etc.
- Information about operational disruptions and appropriate measures.
- DHW mixing valve placement and settings.
- Safety valve function test.
- Warranties and insurance.
- Installation verification/warranty filled in and posted.
- Information and procedures for reporting faults.

Date/Customer

Date/Installer

4. Serial number

The serial number can be read from the barcode on the data plate. Digits 5 and 6 plus the last 6 digits make up the serial number.

TRYCKBEREDARE I ROSTFRITT STÅL

CTC MODUL 400 E15

IP44 50-60Hz

VOLYM 380

ARBETS TRYCK 1MPa(10bar)

KW 7,5

VOLT 400 3N~





010126000000000000

RoHS



MAX. 110 grC
VARNING FÖR SPRÄNGNINGSRISK
Säkerhetsventilens utlopp får inte blockerats
Läs monterings och instruktions manualen innan montering. Vid avstängning av vattenförsörjning måste strömförsörjning vara avstängd.
Säkerhetsventilens fria rörelse skall provas regelbundet genom att öppna ventilen och se till att vattnet rinner i utloppet.
Termostat, element och säkerhetsventil får endast bytas ut mot motsvarande godkänd typ. Elektrisk anslutning och reparation måste utföras av auktoriserad elektriker.

CTC AB
Näsvägen 8
Ljungby
Sweden
Prod. Høiax for CTC

STB-MOD-M-Y-C-CTC 589801001

5. Important to remember!

Check the following points in particular on delivery and installation:

5.1 Transportation

- Transport CTC Module to the installation site before removing the packaging. The product must be transported and stored in an upright position. Handle the product in the following manner:
 - Forklift truck
 - Lifting strap around the pallet. NOTE! Can only be used with the packaging on. Remember that the product has a high centre of gravity and should be handled with caution.

5.2 Positioning

- Remove the packaging and check before installation that the product has not been damaged in transit. Report any transport damage to the carrier.
- Place the product on a solid surface, preferably a concrete foundation, and stabilise using the adjusting screws at the bottom of the tank. Models without adjustment screws can be stabilised with spacers. This must be done before connecting the hot water storage tank to piping and before it is filled with water.

If the product needs to be placed on a soft carpet, base plates must be placed under the adjustable feet.
- Remember to leave an open area of at least 1 metre in front of the product for servicing. Space is also needed around the product for fitting insulation and the top panel.
- The product must not be placed below floor level.
- Connections that are not being used must be appropriately plugged. During water filling, condensation may occur on the tank exterior. This may be visible as water on the floor underneath the tank. This condensation will stop once the tank is heated. The floor drain must be located in the same area.

5.3 Recycling

- The packaging must be deposited at a recycling station or with the installer for correct waste management.
- Obsolete products must be disposed of correctly and transported to a waste station or distributor/retailer offering this service. Disposing of the product as household waste is not permitted.

5.4 After commissioning

- The installation engineer advises the property owner on the construction and servicing of the system.
- The installer fills in the contact information and checklist, which the customer and installer sign.
- Make sure to register for warranty and insurance on the CTC website.

www.ctc.se/registrera-din-installation-for-garanti/

6. System components

Depending on needs and conditions and the layout of the installation space, a number of system components are required. The following system components can be obtained from CTC:

CTC Module 300/400 E15, power module

- 1x stainless steel 282/380 litre tank
- 3x 2.5 kW electrical element, installed in the tank (switchable to 3x 5 kW).
- Clamps and Teflon O-ring for connection to additional tank
- Connections for external heat source, e.g. heat pump
- Adjustable feet.



Clamps and Teflon O-ring for connection to additional tank.

CTC Module 400 L, storage tank

- 1x stainless steel 380 litre tank
- Clamps and Teflon O-ring for connection to additional tank
- Connections for external heat source, e.g. heat pump
- Adjustable feet.



Assembly accessories for connecting to hot and cold water, respectively.

Accessories

- *Assembly accessories: Tap water G1½", required for installation*
- *Thermostat kit 55–85°C, if needed for other temperature control.*

7. Technical data / Energy labelling

Technical data	CTC Module 400 L	CTC Module 300 / 400 E15
Article number	589802001	589800001 / 589801001
Electrical data	-	400V 3N~ 50Hz
IP class	IP44	IP44
Volume (V)	L	380
Max. operating pressure (PS)	kPa/Bar	282 / 380
Max. operating temperature (TS)	°C	10
Weight excl. packaging (net)	kg	100
Weight incl. packaging	kg	58
Dimensions incl. packaging (D x W x H)	mm	49 / 61
Dimensions excl. packaging (Ø x H)	mm	56 / 66
Width incl. connections	mm	714
Pipe connections on the tank	Flanged, intended for clamps	600 x 600 x 1840 / 750 x 750 x 2300
		Ø585 x 1582 / Ø646 x 2132
		631 / 714
	Flanged, intended for clamps	Flanged, intended for clamps

Energy labelling ¹⁾	CTC Module 400 L	CTC Module 300 / 400 E15
Energy efficiency class	C	D / D
Standing loss	W	94,8
Load profile	-	-
Energy efficiency	%	XL / XL
Annual electricity consumption, AEC	kWh	37,6 / 37,6
Thermostat — temperature setting	°C	4458 / 4459
	-	60

¹⁾ in accordance with Commission Regulation (EU) No. 814/2013 of 2 August 2013.

Pressure drop in tanks

CTC Module is series connected with a flange connection. The diagram shows the pressure drop in kPa in series connection depending on the flow and number of tanks connected in series (1–12).

Important to remember regarding the flow through the tanks: The modules provide approx. 60°C water, which is mixed with cold water down to approx. 40°C. Therefore, only approx. 50% of the total water flow moves through the tanks. The diagram shows the flow through the tanks.

For example: A school has 40 shower units that are simultaneously used at 12 l/min. A total of 480 litres/min results in a through-flow in the tanks of approx. 240 litres/min (50%), which with 4 tanks is equivalent to approx. 60 kPa in the above diagram. In a large system, tank rows can be connected in parallel to reduce the pressure drop.

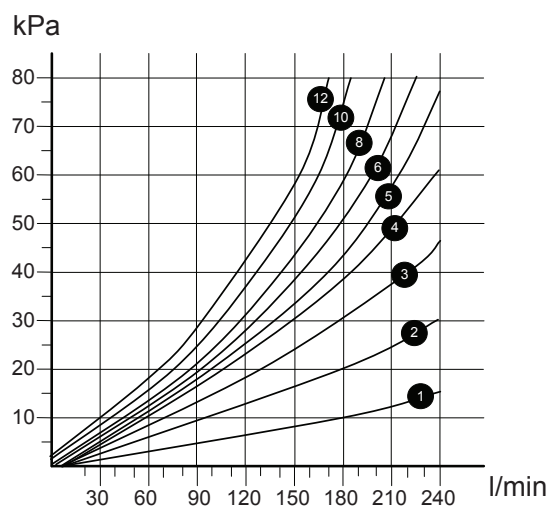

Dimensional drawing, CTC Module 300 E15

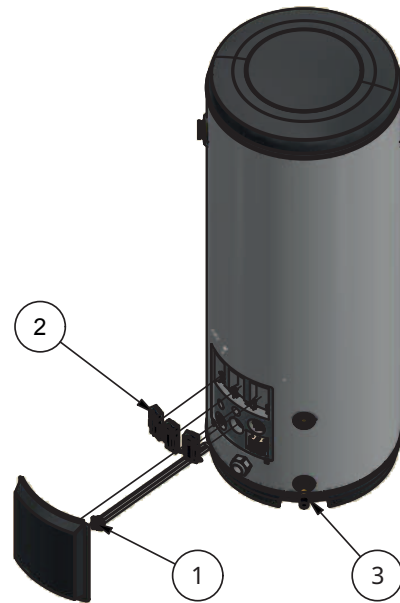
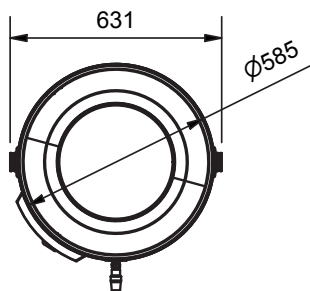
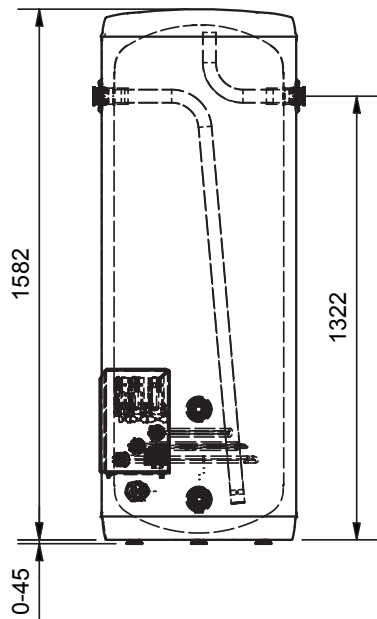

Article number	Model
589800001	CTC Module 300 E15

Position	Qty	Article name	Article number
1	1	Immersion heater 7.5 kW / 15 kW 1", 1-phase L=420 mm	589803301
2	3	Thermostat 45-75°C	589804301
3	1	Safety valve	589806301

Dimensional drawing, CTC Module 400 L, 400 E15

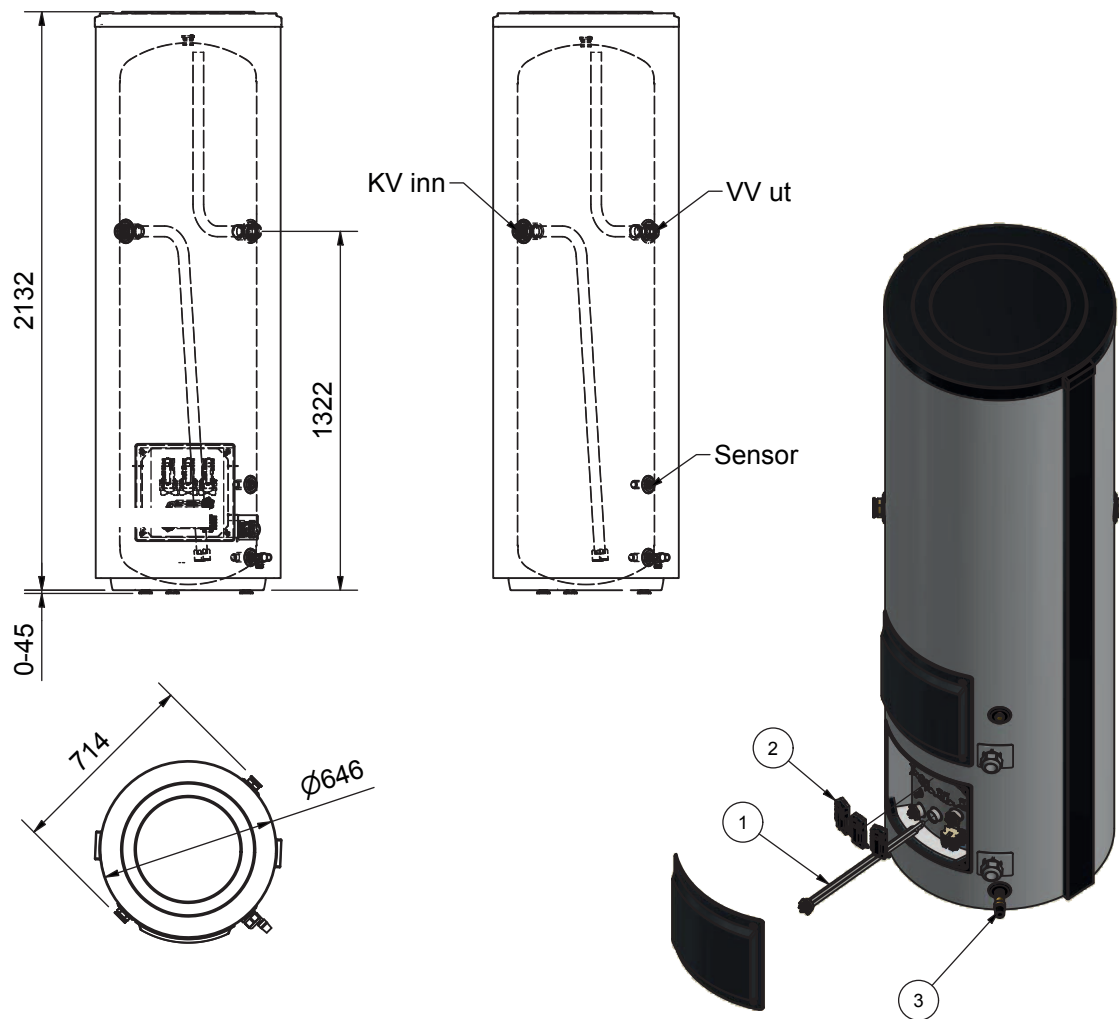

Article number	Model
589802001	CTC Module 400
589801001	CTC Module 400 E15

Position	Qty	Article name	Article number
1	1	Immersion heater 7.5 kW / 15 kW 1", 1-phase. L=420 mm	589803301
2	3	Thermostat 45-75 °C	589804301
3	1	Safety valve	589806301

8. Pipe installation

General

This chapter is for the person responsible for one or more of the necessary installations. Take your time going through functions and settings with the property owner and answer any questions. Installation must be performed by a qualified professional.

Water quality

Prior to installation, check to ensure that the chloride content does not exceed 60 mg/l, and that the pH value is not lower than 7.5. Higher/lower values than those stated can damage the product and shorten its service life (corrosion).

Transportation

Transport the unit to the installation site before removing the packaging. When handling, remember that the product has a high centre of gravity.

Unpacking

Check that the product has not been damaged in transit. Report any transport damage to the carrier. Check that all parts and components are included in the delivery. Tips: Unpack the product once it is standing close to the installation site.

General pipe installation

The installation must be carried out in accordance with the applicable standards.

Shut-off valve

Installed on the incoming cold tap water line.

Backflow protection

The type of backflow protection should be selected according to SS-EN 1717 and installed on the incoming cold water line.

Check valve on mixing valve

A check valve is installed on the mixing valves cold water connection. This prevents backflow when the charge pump is operating.

Check valves on charging circuits

A check valve is installed on the charging circuit(s) according to the system images.

Safety valve

A safety valve with an opening pressure of max. 10bar is installed on the respective CTC storage module/power module.

Overflow pipe from safety valve

Connect the overflow pipe to the floor drain directly or, if the distance is more than 2 metres, to a funnel. The overflow pipe must slope towards the floor drain, be installed frost free and left open to the atmosphere/without pressure.

Manometer for cold tap water

Installed on the incoming cold tap water line.

Expansion vessel for cold tap water

To avoid loss of overflow water (discharged during expansion of the water upon heating), an expansion vessel is installed in direct connection to the tanks incoming cold tap water connection. The size of the vessel depends on the volume that has been selected in the system. Ensure that the vessel has the correct pressure.

Connection of tanks

In order to facilitate installation of multiple tanks in one system, the tanks are equipped with a flange coupling. An ingenious hose coupling with O-ring enables a very compact installation.

Connection of external heat source, e.g. heat pump or solar energy

An external heat source can be connected to the system according to the system options below. Note that it is connected to a fresh water connection, which is why an intermediate heat exchanger (shown) is required. Ensure that the intermediate heat exchanger is correctly dimensioned to avoid problems, primarily with the heat pump connection. No operating diagram for connecting an external heat source is provided in this manual.

Pumps

The charge pumps that are shown in the system option work with fresh water. Ensure that the selected pumps are intended for fresh water operation.

Vacuum valve (back-siphonage protection)

A vacuum valve must be installed on the boilers cold water side if there is a risk of vacuum, e.g. when draining the system.

 **Important! The tanks must be flushed following installation, see the "Commissioning" section.**

9. System options

The CTC module tank system is flexible and can be connected in different ways depending on needs and conditions. Some examples of connections are shown below. The system can be extended and adapted with an optional number of tanks as required.

9.1 System 1

Connected heat pump with Legionella function

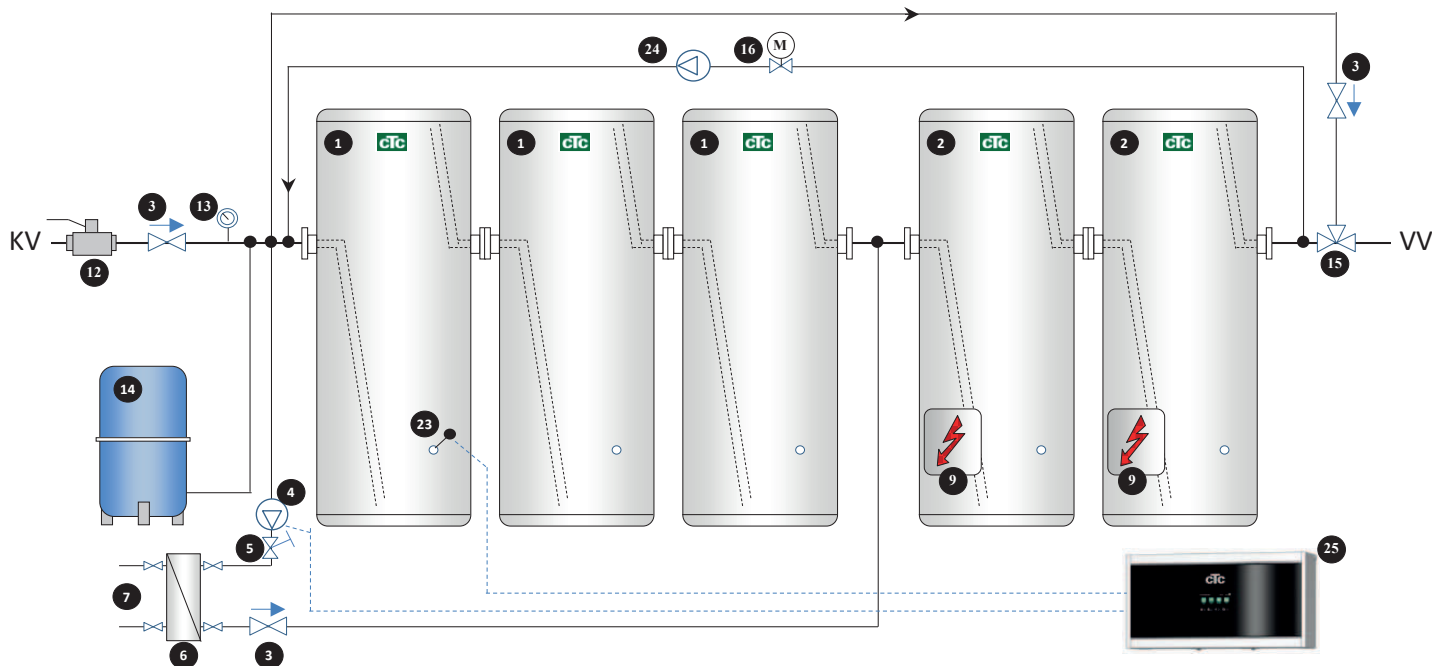

- | | | | |
|---|--|----|--|
| 1 | Storage module 400 L | 12 | Valve shut-off |
| 2 | Power module 400 E15 | 13 | Manometer, cold tap water pressure |
| 3 | Check valve | 14 | Expansion vessel |
| 4 | Charge pump, external heat source | 15 | Mixing valve, hot tap water |
| 5 | Adjustment valve, flow | 16 | Solenoid valve, Legionella protection function |
| 6 | Exchanger, external heat source | 23 | Sensor, tank temperature |
| 7 | Connection of external heat source (heat pump) | 24 | Pump, Legionella protection function |
| 9 | Immersion heater | 25 | Control system (CTC EcoLogic) |

Choose this system when significant amounts of hot water are desired, but where rapid heating of a partial volume is also needed, i.e. draw-offs may be irregular.

The power modules (2) ensure that hot water is always available for the hot tap water system. As the water heated by the heat pump in the third storage module is charged "backwards" in the tanks, full temperature/capacity is achieved in the tanks that have finished charging.

This system is used when the external heat source consists of a heat pump. The system can be extended to achieve very large capacities according to the principle in the system image.

The hot tap water is post-heated in the power modules (multiple power modules can be connected in series depending on need).

The legionella protection function of the entire tank system works by pumping the power modules hot water to other tanks.

Function

The example in system 1 shows 3x 400 L storage tanks (1) and 2x 400 E15 power modules (2) (alternatively, further power modules can be connected in series). A heat pump (with CTC EcoLogic (25) control system) connected via a charge exchanger (6) (pre)heats the tap water in the storage modules. A sensor (23) is installed on the lower part of the first storage module to start and stop accumulation of hot tap water. When the hot tap water is drained, the sensor (23) cools and both the external heat source (7) and charge pump (4) start. The cold water is heated in the charge exchanger (6) to the correct temperature by adjusting the flow with a valve (5). The heated water circulates "backwards" in the storage tanks. The process continues until all the water is hot and the sensor (23) is satisfied.

Legionella protection function, tank system

In order to maintain a high temperature throughout the tank system, a circulation circuit is installed that connects the storage tanks with the power modules (2). When the Legionella function starts, the solenoid valve (16) opens and the Legionella pump (24) starts. Hot, electrically heated water is thus circulated from the power tanks to other tanks. Sensor (23) stops the Legionella protection function.

Legionella protection function for hot tap water system, and hot tap water circulation

In special cases, e.g. in the case of a large hot tap water system, it may be necessary to periodically increase the temperature of the system to eliminate bacteria (Legionella). The figure below also shows hot tap water circulation (HWC).

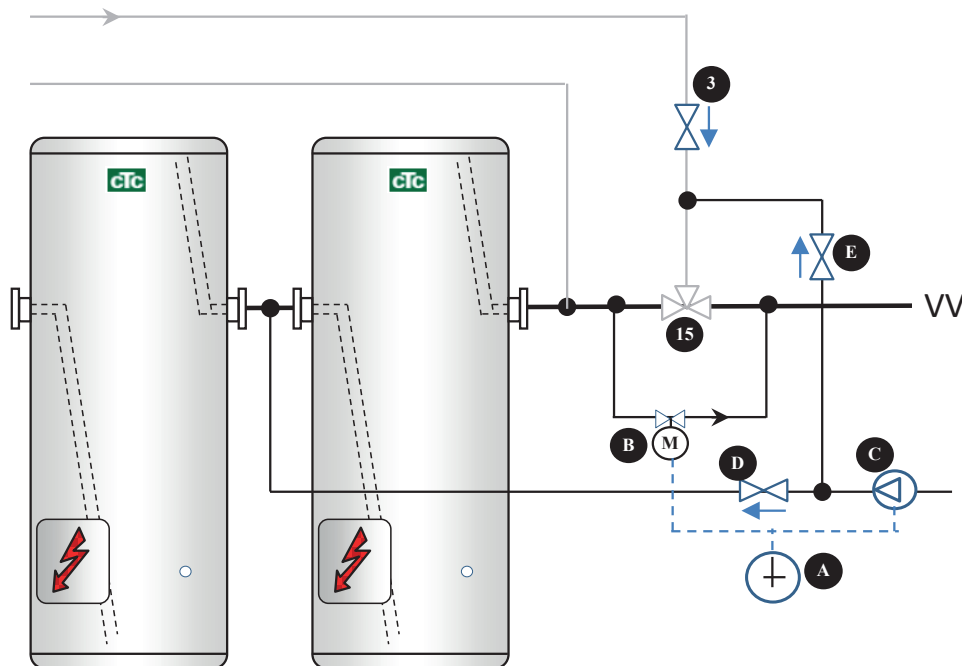

Hot tap water circulation (HWC) function

A separate timer for HWC starts and stops the circulation pump (C) at the times when HWC is desired. The mixing valve (15) is supplied with the cooling hot tap return water, and mixes the hot tank water to the desired temperature. A solenoid valve (B) does not need to be installed if the hot tap water increase function (Legionella protection function) is not installed.

Periodic increase function

The periodic increase function is activated with a timer (A), whereupon the solenoid valve (B) and pump (C) start. Hot water (e.g. 60°C) from the power module is circulated out into the hot tap water system. The return water from the system is distributed back to the power module, and also to the hot tap waters mixing valve if a HWC coupling has been installed.

- A Timer for periodic hot tap water increase and/or HWC
- B Solenoid valve for hot tap water increase
- C Circulation pump
- D Check valve for hot tap water increase
- E Check valve for HWC
- 3 Check valve
- 15 Mixing valve for hot tap water

Warning! Note that the hot tap water systems normal temperature limit is overridden, which is why the temperature at the outlets may become very high when increased, with subsequent risk of scalding. Ascertain and follow rules for this in each individual case where installation is intended to be performed.

9.2 System 2

Charging with an external hot water source,
e.g. pellets etc., downstream charging

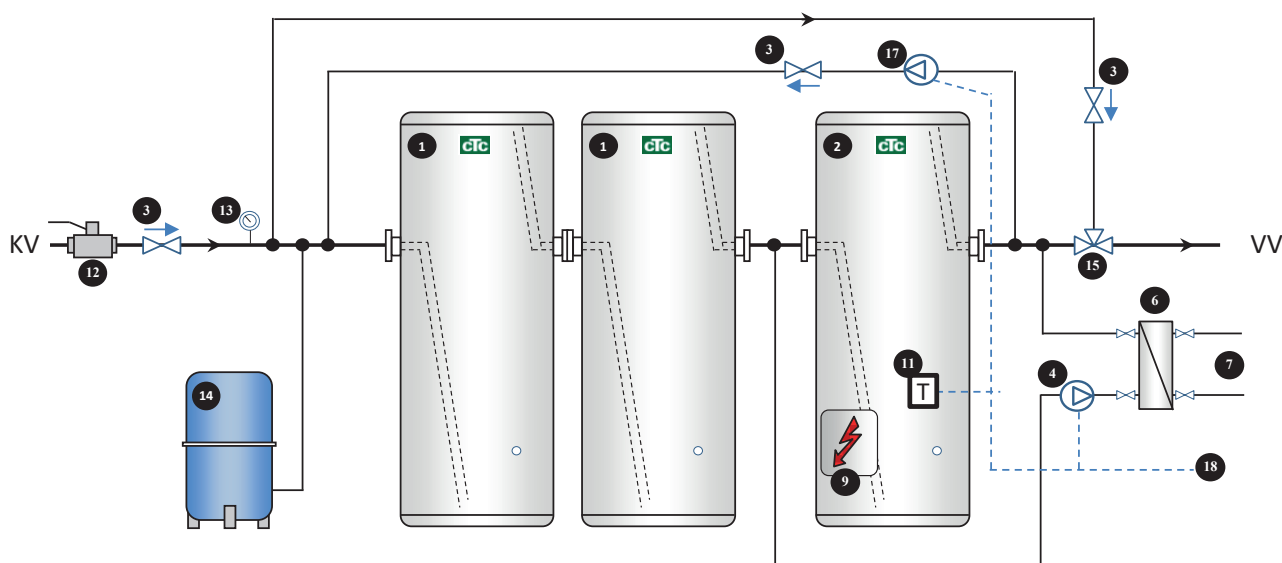

- | | | | |
|---|--|----|---|
| 1 | Storage module 400 L | 11 | Charge thermostat, external heat source and tank system |
| 2 | Power module 400L | 12 | Valve shut-off |
| 3 | Check valve | 13 | Manometer, cold tap water pressure |
| 4 | Charge pump, external heat source | 14 | Expansion vessel |
| 6 | Exchanger, external heat source | 15 | Mixing valve, hot tap water |
| 7 | Connection of external heat source (not heat pump) | 17 | Charge pump, tank system |
| 9 | Electric additional heat (immersion heater) | 18 | Signal to external heat source |

Select this system when significant volumes of hot water are desired at well defined times, and where the charge-up time between drain-offs is adequately long. With or without external heat source.

This depends on the heated water in the power module being transferred to the first tank, i.e. the entire systems volume needs to pass and be heated from the power tank before the systems full capacity is reached.

This coupling is beneficial for applications where you have periodically low tap water requirements, e.g. schools, holiday homes etc. You can then turn off the charge pump for the tank system (17) and just use the power module (2), which is heated by the external heat source (7) or immersion heater (9). This reduces system losses during these times.

The system can be extended to achieve very large capacities according to the principle in the system image.

Function

The example shows 2x 400 L storage tanks (1) and 1x 400 E15 power modules (2). An adjustable charge thermostat (11) is installed on the power module (2) to control the accumulation of hot tap water (e.g. 60°C).

Once the power module (2) is charged to 60°C, the charge pump (17) starts and transfers the heated water to the first storage tank (1), while the colder water in other storage tanks (1) is simultaneously transferred to the power module (2).

If an external heat source (7) is connected, the power tank is charged by this.

A start signal (18) can be obtained from the charge thermostat (11).

Charging with external heat source, e.g. pellets etc., upstream charging

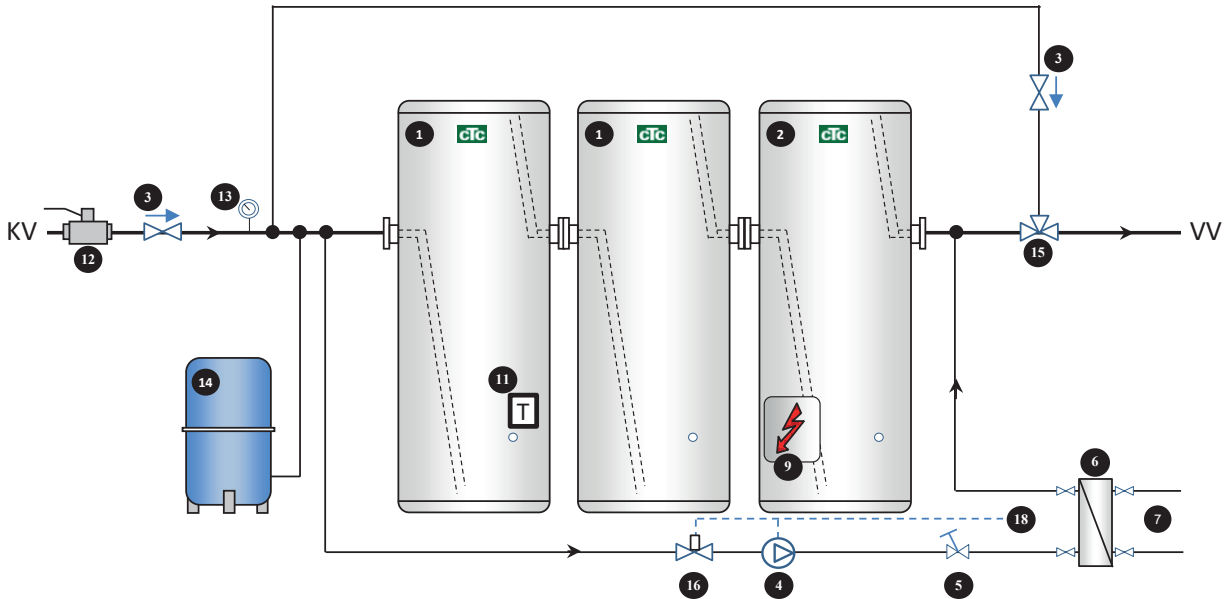

- | | | | |
|---|---|----|---|
| 1 | Storage module 400 L | 11 | Charge thermostat, external heat source |
| 2 | Power module 400 E15 | 12 | Valve shut-off |
| 3 | Check valve | 13 | Manometer, cold tap water pressure |
| 4 | Charge pump, external heat source | 14 | Expansion vessel |
| 5 | Adjustment valve, flow | 15 | Mixing valve, hot tap water |
| 6 | Exchanger, external heat source | 16 | Solenoid valve, charge circuit |
| 7 | Connection of external heat source | 18 | Signal to external heat source |
| 9 | Electric additional heat (immersion heater) | | |

Choose this system when significant amounts of hot water are desired, an external heat source is connected and you also need rapid heating of a partial volume, i.e. drain-offs may be irregular. As the heated water in the power module is charged “backwards” in the tanks, full temperature/capacity is achieved in the tanks that have had time to charge. The external heat source is connected via an exchanger.

The system image shows one tank (2) with an immersion heater, for example, for additional power or/and Legionella protection function. The system can be extended to achieve very large capacities according to the principle in the system image.

The charge flow is adjusted to increase the charge temperature in one step (10–65°C). Alternatively, the temperature in the system can be increased “successively” in several charge cycles. An exchanger can be excluded if an external heat source is not connected.

Function

The example shows 2x 400 L storage tanks (1) and 1x 400 E15 power module (2) (alternatively, one of the storage tanks could be a power module), as well as a heat exchanger for connecting an external heat source, e.g. pellets. An adjustable thermostat (11) is installed on the first storage tank to control the accumulation of hot tap water.

When the first storage tank cools or if drain-off occurs, the charge thermostat (11) starts the charge pump (4) and circulates a specified volume of cold water through the exchanger (6), depending on the exchangers capacity and the setting of the throttle valve (5), to be heated to the desired/set temperature. The circulation continues until all the storage tanks are charged. When the hot tap water is used, cold water enters the first storage module (1), whereupon the cooled charge thermostat (11) starts charging via the exchanger (6) again.

During large drain-offs, the heated water from the other storage tanks is utilised. Two different principles for heating with an external heat source can be applied:

1. Throttling with a throttle valve (5) so that the capacity is sufficient in the exchanger (6) to heat the water to a usable temperature in one step. This is preferable if consumption is irregular and short charge times can be expected.
2. Apply a larger charge flow and increase the temperature in several steps until the entire system reaches the right temperature if the charge time is sufficiently long.

9.3 Flange couplings

The CTC flange coupling system provides a very compact and easy-to-install connection between products.



9.4 Example of installation

Double row

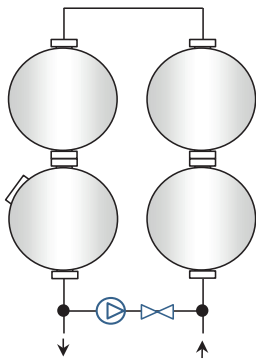

Corner

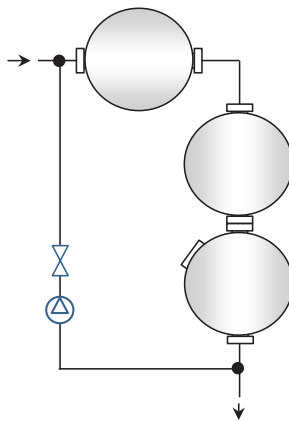

Single row

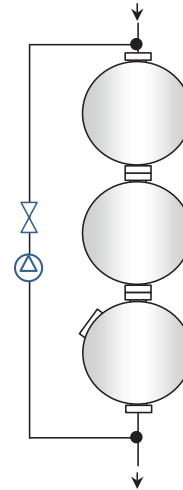

Significant hot water requirement/ installations

If the hot water requirement is very high, it may be necessary to connect the system in series/parallel as shown in the figure below. This reduces the pressure drop in the system. Make sure to install valves that enable adjustment of equal flow between the series-connected rows.

Function

The CTC Module heater system can be combined in many different ways, depending on hot tap water requirements and which energy sources will be used.

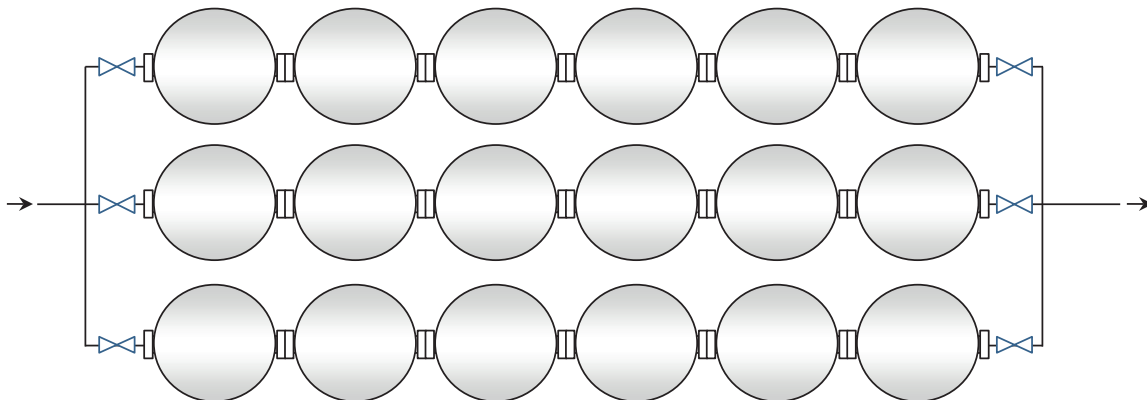

10. Recommendations and design

During design, consumption is calculated over a **3 hour period** with the following intervals:

1-5 apartments	240 l/apartment
6-10 apartments	220 l/apartment
11-15 apartments	200 l/apartment
16-20 apartments	190 l/apartment
21-25 apartments	180 l/apartment
26-35 apartments	175 l/apartment
36-45 apartments	165 l/apartment
More than 45 apartments	150 l/apartment

Average number of people in different sizes of apartment

Normal apartment 1 room and kitchen.....	1 person
Normal apartment 2 rooms and kitchen	1.5 people
Normal apartment 3 rooms and kitchen	2 people
Normal apartment 4 rooms and kitchen	3 people
Normal apartment >5 rooms and kitchen...	3.5 people

Hot water consumption for several common activities in the home:

Hand washing	15 l
Normal shower 3-4 minutes	40 l
Bath (standard bath tub)	140 l

Table 1

Energy content (usable hot water), as well as theoretically required charging power when charging from **10 to 60°C** (heat pump operation) depending on required charge time.

Total volume of storage tanks (L)		400	800	1200	1600	2000	2400	2800
Usable energy content, and also volume 40°C	kWh	32	64	97	130	162	194	227
	L	650	1300	2000	2650	3350	4000	4650
Required charging power during charge time = 1 h (10-60°C)	kW	32	64	97	130	162	194	227
Required charging power during charge time = 2 h (10-60°C)	kW	16	32	49	65	81	97	113
Required charging power during charge time = 4 h (10-60°C)	kW	8	16	24	32	40	49	57
Required charging power during charge time = 8 h (10-60°C)	kW	4	8	12	16	20	24	28

Note 1. A certain margin (10%) should be added when dimensioning depending on the level of layering, drain-off intensity etc.

Example:

Medium-heavy industry with 2 shifts and 30 people showering after each shift (every 8 hours):

Calculated energy requirement according to table 3:

1.8 kWh x 30 pers= 54 kWh + 10%= 60 kWh.

See Table 1: Find the nearest higher value for usable energy content (kWh)= table value 64 kWh. Required accumulator volume will then be 800 l. For 8 hours charge time, 8 kW charging power is required according to the table. Volume 40°C which can be drained is 1300 litres.

Table 2

Energy content (usable hot water), as well as theoretically required charging power when charging from **10 to 75°C** depending on required charge time. (High-temperature heat source).

Total volume of storage tanks (L)		400	800	1200	1600	2000	2400	2800
Usable energy content, and also volume 40°C	kWh	42	84	126	168	211	253	316
	L	850	1750	2600	3450	4300	5150	6050
Required charging power during charge time = 1 h (10–60°C)	kW	42	84	126	168	211	253	316
Required charging power during charge time = 2 h (10–60°C)	kW	21	42	63	84	105	126	147
Required charging power during charge time = 4 h (10–60°C)	kW	11	21	32	42	53	63	74
Required charging power during charge time = 8 h (10–60°C)	kW	5	11	16	21	26	32	37

Note 1. A certain margin (10%) should be added when dimensioning depending on the level of layering, drain-off intensity etc.

Example:

Medium-heavy industry with 2 shifts and 30 people showering after each shift (every 8 hours):
 Calculated energy requirement according to table 3: 1.8 kWh x 30 pers = 54 kWh + 10% = 60 kWh.
 See Table 2: Find the nearest higher value for usable energy content = table value 84 kWh. Required accumulator volume will then be 800 l. For 8 hours charge time, 11 kW charging power is required according to the table. Volume 40°C which can be drained is 1750 litres.

Table 3

Typical energy consumption for different types of industrial facilities.

Type of facility	Type of outlet	Energy consumption	Duration
Industry - light	Shower	0,8-1,2 kWh/person	Approx. 15 minutes after end of work
Industry - medium	Shower	Ca 1,8 kWh/person	
Industry - heavy	Shower	2,3-3,0 kWh/person	
Schools	Shower	Ca 1,2 kWh/pupil	Approx. 10 minutes every 45 minutes
Schools	School dining	0,2-0,4 kWh/pupil	Continuous during dining and dish washing period
Sports facilities	Shower	Ca 2,3 kWh/person	Depending on type of activity
Swimming pools	Shower	Ca 2,5-3,5 kWh/person	
Hotel - single room	Washbasin	0,6 kWh	Depending on number of guests and category of hotel
Hotel - single room	Shower	2,0 kWh	
Hotel - single room	Bath	6,4 kWh	
Hotel - double room	Shower	2,9 kWh	
Hotel - double room	Bath	8,1 kWh	
Restaurant - service	Kitchen	0,6-1,2 kWh/person	
Restaurant - self-service	Kitchen	0,4-0,6 kWh/person	
Café	Kitchen	Ca 0,3 kWh/person	

11. Electrical installation

Immersion heater 7.5 kW, CTC Module 300/400 E15

The immersion heater consists of 3x 2.5 kW electrical heaters, which are switchable to 3x 5 kW. Installation, replacement and servicing of the products immersion heater must be performed by a qualified electrical installer. All wiring must be performed according to applicable provisions. The boilers internal wiring is installed at the factory.

Electrical installation occurs on the terminal block under the cover of the immersion heater.

Connection cables are inserted in the intended cable bushings.

Power supply

The product is connected to 400V 3N~, 50Hz +earth.

Safety switch

The product must be shut down by an omnipolar safety switch.

Thermostat/safety thermostat

The immersion heaters operating temperature must be set. This is done on the thermostat, which is installed on the outer surface of the tank, close to the immersion heater. The factory setting is 60°C and the thermostat can be set up to 75°C.

In the event of a fault, the safety thermostat may be triggered (at 100 °C). It can be reset using the thermostats reset button, once the temperature of the tanks has reduced.

Charge thermostat

The thermostat for hot water charging is installed on the tank according to the selected connection option.

The pump is connected between P1 and 2 (230V 1N~, 50Hz).

Materials for connecting to 3x 5 kW are available in a supplementary package.

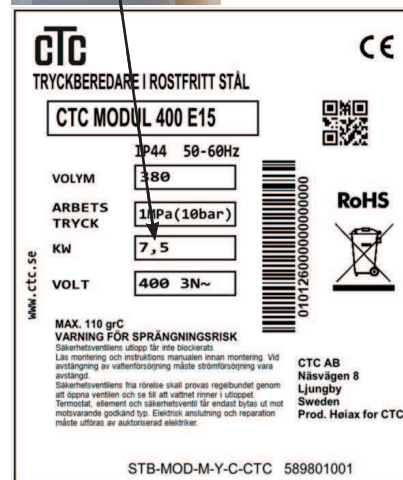

When connecting from 7.5 kW to 15 kW, the product must be re-labelled with the enclosed sticker.



Connection box

11.1 Wiring diagram, immersion heater

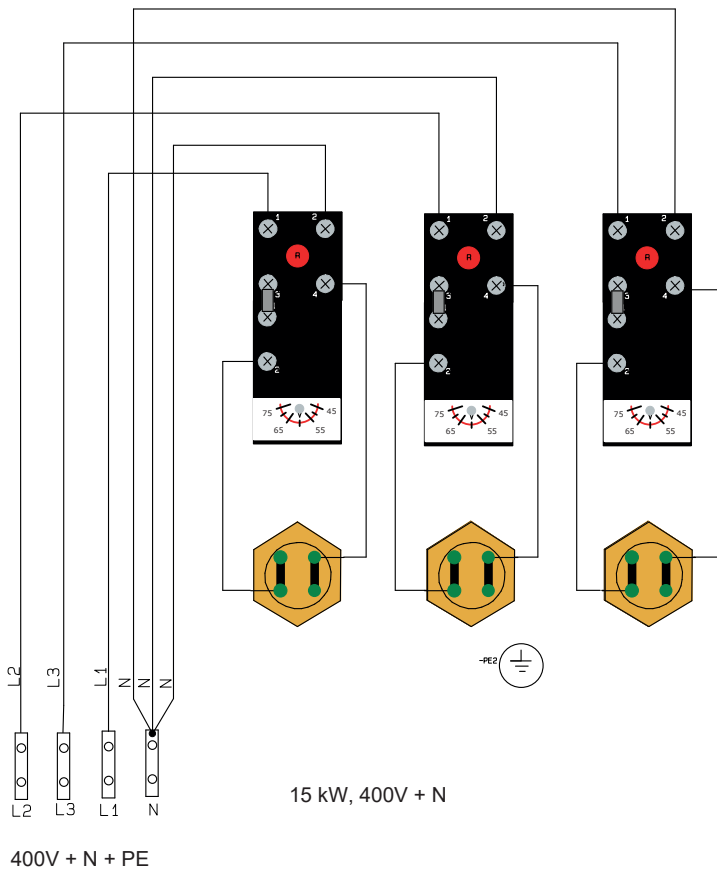
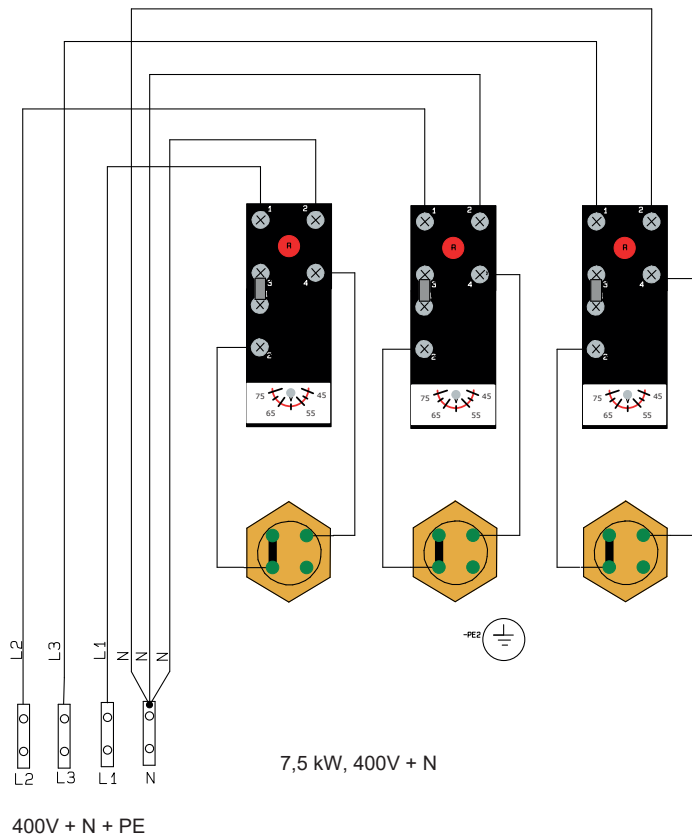

12. Commissioning

Installation check

Once installation is completed, review and tick off the items on the checklist (see section checklist).

Flushing of tanks

The corrosion resistance of the tanks must be ensured when the tanks enter service after the completed installation. The non-corrosive tanks are manufactured from high-quality stainless steel and, in order to achieve the best possible resistance against aggressive water, the tanks **must** be flushed with cold water before commissioning. This is to build up the oxide layer on the inside of the tanks. **Flush the system for at least 1 hour with fresh water.**

Significant consumption of hot water is also recommended in the period immediately after installation, which further strengthens the protection.

Before energisation

Ensure that the system is filled with water and vented. Open a hot water tap when filling. In particular, check that the charging system is properly vented.

Safety valve

All CTC tanks are pressure tested and supplied with a 10 bar safety valve.

Expansion vessel

The cold water expands during heating. If the facility has a throttle or check valve on the cold water inlet, the safety valve will then open. This can be prevented by installing an expansion vessel at the inlet. The expansion vessel is connected to the tanks incoming cold water tap connection, between the check valve and the first tank. The size of the vessel is dimensioned depending on the volume that has been selected in the system. Ensure that the vessel has the correct pre-pressure. If a circulation pump is installed for internal circulation, it must be stopped with the respective switch or by pulling out the plug.

Emptying the tank

All immersion heaters in the tank system have 1" threads and a length of 420 mm. When changing the immersion heater, use a specific 58 mm wrench. When a tank has to be emptied, close the tanks cold water tap and service valve (if installed) on the hot water side. The pressure in the tank is neutralised by opening one or more safety valves or a tap. By opening a drain valve at the bottom of the tank, the tank can be emptied of water. To empty the entire tank system, the valves must be opened on all tanks.

NOTE!

- Remember to vent on the top side of the tank to avoid vacuum formation.
- When dismantling and reinstalling, the flange couplings O-rings must be replaced.
- Tanks with immersion heaters must be electrically disconnected before emptying occurs.

13. Operation and maintenance

After installation

When the system has been installed, the user and installer must together check that the system is in full working order. Let the installer show you where the power switches, controls, valves, fuses, safety valves etc. are so that you know how the system works and how it should be maintained. The system may need to be ventilated after several days of operation. Also, check for any leakage after several days of operation and tighten if required.

Periodic maintenance

Power and storage tanks do not normally require any special maintenance, however certain checks must be periodically performed according to the following schedule:

Action/check	Time period	Note
Flushing of fresh water for at least 1 hour (10–15 l/minute)	In connection with completion of installation, before commissioning	Strengthen the corrosion resistance (oxide layer). Preferably use large volumes of hot water immediately after the installation (large throughput); this further strengthens the protection.
Checking the function of safety valves	In connection with completion of the installation, then 3–4 times per year	Activate the valves by turning the knob until a "click" is heard. A small amount of water will come out from the valves outflow line.
Leakage check	After three weeks operation and then every three months during the first year. Then once per year.	Be aware of oxide deposits around connections; this can indicate a very small leakage.

Downtime

If the system has to be turned off for a period, ensure the following:

- That taps, valves etc. are closed/set in a position that means that the system cannot be damaged during downtime
- That the entire system is drained of water if there is a risk of freezing, also ensure that the electric current to immersion heater(s), pumps etc. is disconnected
- Check safety valves and other functions when the system is re-commissioned
- When draining, ensure that air can enter the tanks (open any hot water taps)

14. Thermostat for immersion heater

Operating temperature

A combined operating/max thermostat is installed on the outer surface of the tank, close to the immersion heater. The thermostat controls the connection and disconnection of electrical power at the temperature that is set on the thermostat.

Setting of the thermostat must be performed during electrical installation and must be performed/changed by a qualified electrical installer, as the space contains powered parts. The systems safety switch must be switched off when such measures are performed.

The operating temperature can be set up to 75°C, with a factory setting of 60°C.

Safety thermostat

The purpose of the safety thermostat is to permanently cut the power to the immersion heater if a fault occurs, e.g. a faulty operating thermostat.

The safety thermostat trips at 100 °C and must be manually reset. Reset must only be performed by a qualified electrical installer, as the space contains powered parts. The systems safety switch must be switched off when such measures are performed.

The temperature of the tanks needs to reduce before resetting can occur.

15. Troubleshooting and actions

The list below presumes that the installation is correctly dimensioned and has been functioning from the start. Fault has occurred "suddenly". Measures that involve intervention in the product must be performed by a qualified installer/service technician.

Symptoms	Probable/possible fault	Info/action
Inadequate temperature at outlets	Occasional abnormally large hot water consumption, or inadequate recharge time	<ul style="list-style-type: none"> • Wait for normal consumption again, no action • If greater consumption is expected in future, increase the dimensions of the tanks storage volume or increase the charging temperature, if possible, or increase the charging power if the re-charge time is the probable fault.
	Mixing valve for hot tap water	<ul style="list-style-type: none"> • The mixing valve for the hot tap water is set too low; increase the setting • The valve is defective/jammed, replace/service the valve. Check the temperature of the hot water gates before and after the valve, respectively.
	The tanks charging system is faulty	<ul style="list-style-type: none"> • Circulation/charge pump switched off or faulty; check power switches and function • The charging systems check valve is faulty; check that the charging pipe is evenly heated along its entire length (same temperature as the temperature in the power tank) when the circulation pump is in operation • Laddtermostaten felaktigt inställd eller ur funktion; kontrollera att laddpumpen får spänning då effekttanken är varm.
	External heat source faulty/out of function	<ul style="list-style-type: none"> • The safety thermostat has been triggered; reset the thermostat and investigate the cause of the fault • Drifttermostaten till elpatronen felaktig; byt termostat. • The immersion heaters power switch is switched off; turn on • The systems safety switch is switched off; turn on • Faulty immersion heater; measure the immersion heater and change if needed • Electricity supply to the immersion heater is faulty/absent; check all phases for the immersion heater • Troubleshoot/check its function
Water at outlets too hot	Mixing valve for hot tap water	<ul style="list-style-type: none"> • The mixing valve for the hot tap water is set too low; increase the setting • The valve is defective/jammed, replace/service the valve. Check the temperature of the hot water gates before and after the valve, respectively.



CTC AB
Box 309 SE-341 26 Ljungby
+46 372 88 000
info@ctc.se
www.ctc.se