



Installation and Maintenance manual

CTC EcoPart 400

Modell 406-417

400V 3N~ / 230V 1N~



Translation of the original instructions.

Keep for future use.

Read carefully before use.

162 505 94-4 CR01132 2025-11-03



MADE IN SWEDEN

Removing the cooling module

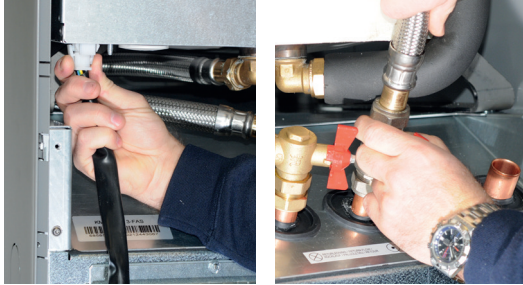

1. Disconnect the cooling module's power cable connector and hoses.



2. Attach the two carrying handles to the bottom of the cooling module.



3. Unscrew the cooling module's screws.



4. Pull the cooling module by first lifting the front edge slightly with the carrying handles.



5. Lift the cooling module using the carrying handles and shoulder straps.

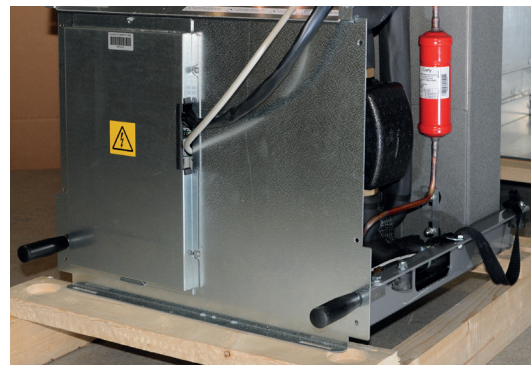

6. Lift the cooling module into the product using the carrying handles and shoulder straps. Remove the carrying handles and reconnect the power cable, hoses and screws.

Installation and Maintenance Manual

CTC EcoPart 400

Modell 406-417

400V 3N~ / 230V 1N~

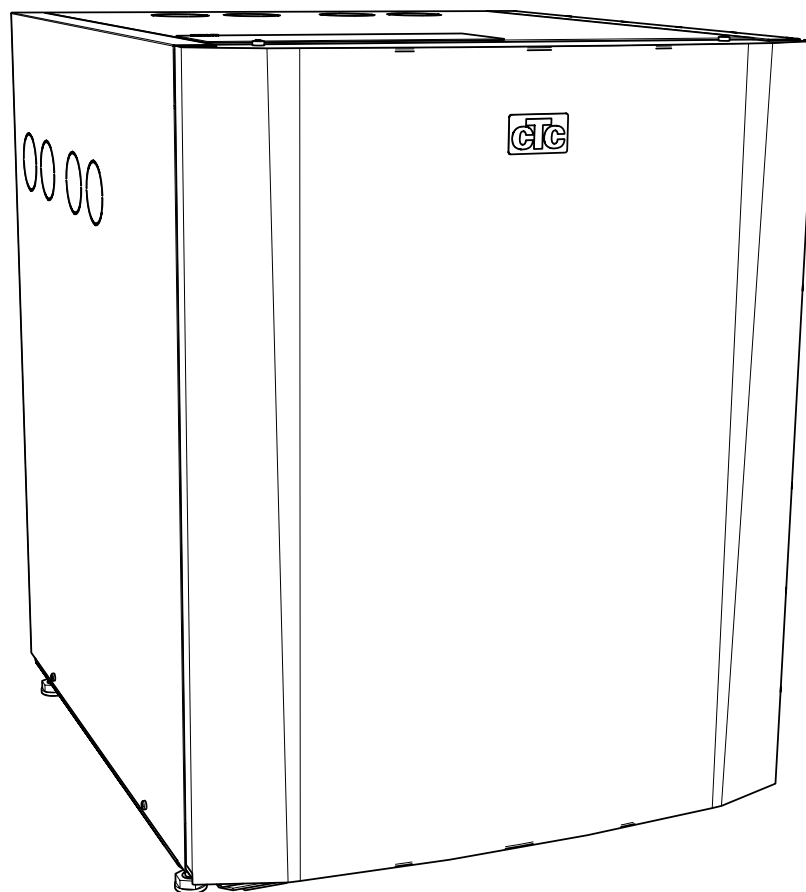

Table of Contents

1. Important to remember!	6	8. Communication connection	24
2. Safety instructions	6	8.1 CTC Basic Display (accessory).....	24
3. Checklist	7	8.2 Option 1 – Connection of one heat pump.....	25
4. Connection options	8	8.3 Option 2 – Series connection of heat pumps.....	26
5. Technical data	9	8.4 Option 4 – CTC EcoEl v3.....	27
5.1 CTC EcoPart 406-412, 400V 3N~.....	9	8.5 Option 5 – CTC EcoZenith i550 v3.....	28
5.2 CTC EcoPart 414-417, 400V 3N~.....	10	8.6 Option 6 – CTC EcoLogic v3.....	29
5.3 CTC EcoPart 406-410, 230V 1N~.....	11	8.7 Connecting the control system.....	30
5.4 CTC EcoPart 412-414, 230V 1N~.....	12	8.8 Wiring diagram 400V 3N~.....	35
5.5 Component location.....	13	8.9 Wiring diagram 230V 1N~.....	36
5.6 Dimensions diagram.....	13	8.10 Parts list.....	37
5.7 Refrigerant system.....	14	8.11 Resistances for sensors.....	38
5.8 Operating range.....	14	9. First start	40
6. Installation	15	10. Operation and Maintenance	40
6.1 Connection of the heat medium side.....	16	10.1 Periodic maintenance.....	40
6.2 Connecting the brine system.....	17	10.2 Operation stop.....	40
6.3 Brine pump.....	20	10.3 Service position.....	40
7. Electrical installation	22	11. Troubleshooting	41
7.1 Electrical installation 400V 3N~.....	22	11.1 Air problems.....	41
7.2 Electrical installation 230V 1N~.....	23	11.2 Alarm.....	41
7.3 Alarm output.....	23		
7.4 Groundwater heating.....	23		

When contacting CTC, always mention the following:

- Serial number
- Model/Size
- the fault message shown in the display
- Telephone number

Fill in the information below. It may come in useful if anything should happen.

Product:	Serial number:
Installer:	Name:
Date:	Tel. no.:
Electrical installer:	Name:
Date:	Tel. no.:

No liability is accepted for any misprints. We reserve the right to make design changes.

Software update



software.ctc.se

EN

For more information on updated functions and downloading the latest software, see the website "software.ctc.se".

Congratulations on buying your new product!



The complete heat pump for rock, ground or lake

CTC EcoPart 400 is a heat pump that draws heat from bedrock, the ground or a lake and conveys it to the existing heating circuit in your house. CTC EcoPart 400 is fully utilised before the normal heating circuit is switched on and helps heat the house.

The heat pump can be connected to CTC EcoZenith or to an existing boiler via the CTC EcoLogic control system.

The CTC EcoPart 400 has been designed to operate with high efficiency and low noise level.

Save this manual containing the installation and maintenance instructions. If it is looked after properly, you will be able to enjoy the use of your CTC EcoPart 400 for many years. This manual will provide all the information you will need.

CTC EcoPart 400 is available in multiple versions

CTC EcoPart 406-412 (LEP)

- A-rated brine pump (Low Energy Pump - LEP)
- No charge pump

CTC EcoPart 414-417 2xLEP

- A-rated brine pump (Low Energy Pump - LEP)
- A-rated charge pump (Low Energy Pump - LEP)

1. Important to remember!

Check the following points in particular at the time of delivery and installation:

- The product must be transported and stored in an upright position. When moving the product, it can be placed temporarily on its back.
- Remove the packaging and check before installation that the product has not been damaged in transit. Report any transport damage to the carrier.
- Place the product on a solid foundation, preferably made of concrete. If the product needs to be placed on a soft carpet, base plates must be placed under the adjustable feet.
- Remember to leave a service area of at least 1 metre in front of the product.
- The product must not be placed below floor level either.
- Avoid placing the product in rooms where the walls are of lightweight design, as people in the adjoining room may be disturbed by the compressor and vibrations.
- Ensure that pipes used between the heat pump and the heating system are of adequate dimensions.
- Ensure that the circulation pump has sufficient capacity to pump the water to the heat pump.
- Register the product for warranty and insurance via the website <https://www.ctc-heating.com/customer-service#warranty-registration>

 Information in this type of box [i] is intended to help ensure that the product functions optimally.

 Information in this type of box [!] is particularly important for correctly installing and using the product.

2. Safety instructions

The following safety instructions must be observed when handling, installing and using the product:

- Close the safety switch before doing any work on the product.
- The product must not be flushed with water.
- When handling the product with a hoist ring or similar device, make sure that the lifting equipment, eyebolts and other parts are not damaged. Never stand under the hoisted product.
- Never jeopardise safety by removing bolted covers, hoods or similar.
- Never jeopardise safety by deactivating safety equipment.
- Any work on the product's cooling system should be carried out by authorised personnel only.
- This product is intended for indoor installation only.

This product is not intended for use by persons (including children) with reduced physical, sensory or mental capabilities or lack of experience and knowledge, unless they have been given guidance or instructions on the use of the product by a person responsible for their safety.

Make sure that children do not play with the product.

 If these instructions are not followed during the installation, operation and maintenance of the system, CTC's liability under the applicable warranty terms is not binding.

3. Checklist

The checklist must always be completed by the installation engineer

- If a service is performed, you may be required to provide this document.
- Installation must always be done according to the installation and maintenance instructions.
- Installation must always be carried out in a professional manner.

Following installation, the unit must be inspected and functional checks performed as indicated below:

Pipe installation

- Heat pump filled, positioned and adjusted in the correct manner according to the instructions.
- The heat pump is positioned so that it can be serviced.
- Capacity of the charge/radiator pump (depending on type of system) for the flow required.
- Open radiator valves (depending on type of system) and other relevant valves.
- Tightness test.
- Bleed the system.
- Check proper operation of the requisite safety valves.
- Requisite waste pipes connected to the floor drain (depending on type of system).

Electrical installation

- Safety switch.
- Correct and taut wiring.
- Requisite sensors fitted.
- Accessories.

Customer information (adapted to the relevant installation)

- Start-up with customer/installer.
- Menus/controls for selected system.
- Installation and Maintenance Manual handed over to the customer.
- Check and filling, heating circuit.
- Information on fine adjustments.
- Alarm information.
- Function test of fitted safety valves.
- Register your Installation Certificate at ctc-heating.com.
- Information on fault reporting procedures.

Date/Customer

Date/Installer

4. Connection options

The illustration below shows the different connection options available for CTC EcoPart 400. In some cases, CTC Converter and CTC Basic display may be required.

Alternative

The CTC EcoPart 400 can be connected to the products below.

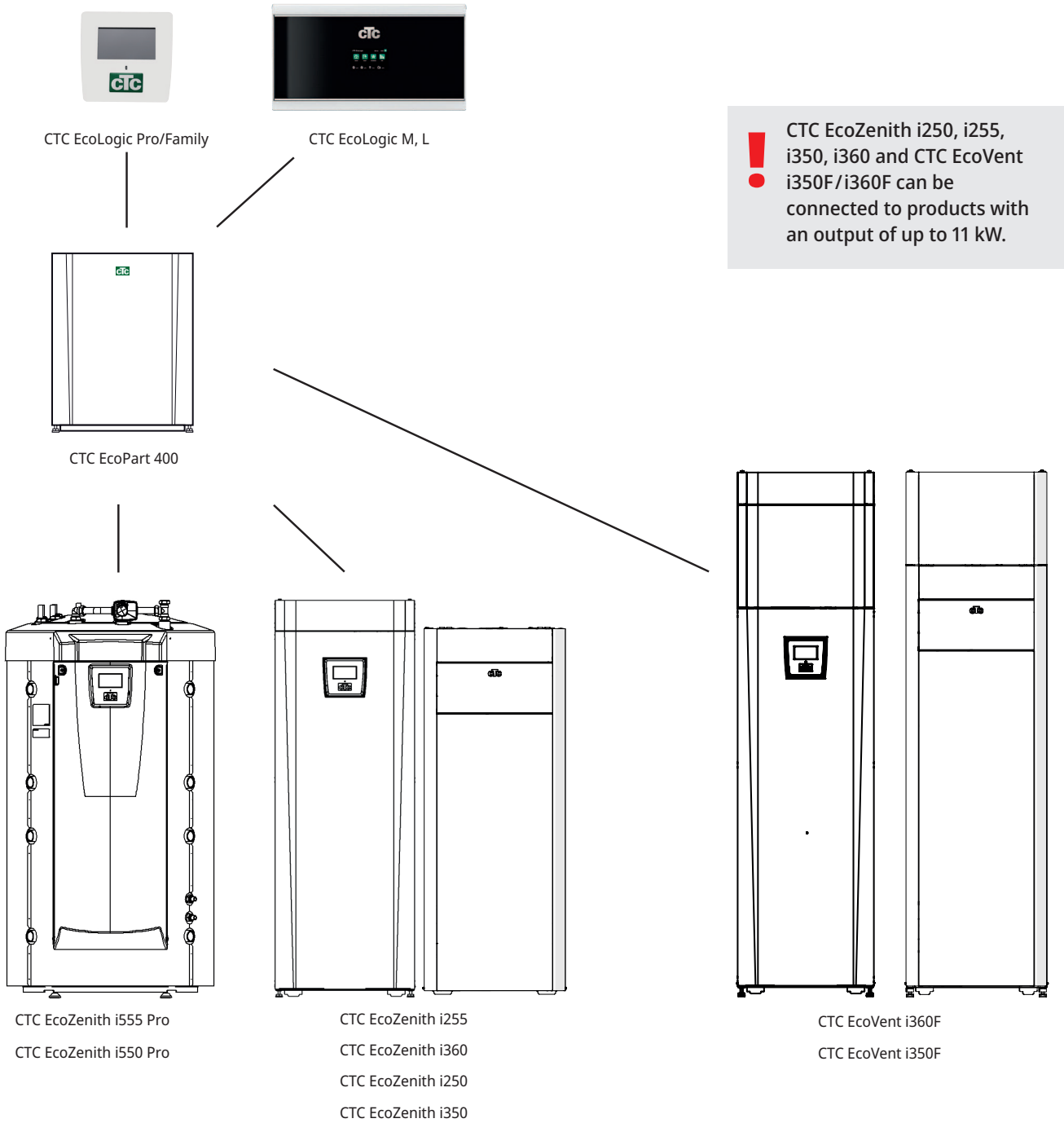

5. Technical data

5.1 CTC EcoPart 406-412, 400V 3N~

Electrical data	CTC EcoPart 406	CTC EcoPart 408	CTC EcoPart 410	CTC EcoPart 412	
Rated electrical data	400V 3N~ 50Hz				
Rated power	kW	2.7	3.5	4.2	5.1
Rated current	A	5.8	6.5	8.1	9.6
Max starting current	A	16.6	17.7	19.8	23.5
Max group fuse	A	10	10	10	10
Ingress Protection class (IP)	IP X1				

Operational data for heat pump						
Output from compressor ¹⁾	@ -5/45	kW	4.54	6.72	8.07	9.63
COP ¹⁾	@ -5/45	-	2.95	3.14	3.15	3.17
Output from compressor ¹⁾	@ 0/35 0/45 0/55	kW	5.90 5.48 5.17	8.19 7.87 7.55	9.97 9.55 9.28	11.75 11.24 10.97
Input power ¹⁾	@ 0/35 0/45 0/55	kW	1.29 1.55 1.87	1.79 2.16 2.53	2.17 2.60 3.11	2.55 3.07 3.71
COP ¹⁾	@ 0/35 0/45 0/55	-	4.57 3.54 2.76	4.58 3.64 2.99	4.60 3.68 2.98	4.60 3.66 2.96
Output from compressor ¹⁾	@ 5/35 5/45 5/55	kW	6.81 6.49 6.08	9.44 9.05 8.65	11.42 10.99 10.58	13.53 12.95 12.57
COP ¹⁾	@ 5/35 5/45 5/55	-	5.24 4.15 3.18	5.02 4.04 3.30	5.20 4.16 3.28	5.11 4.11 3.35
Max. operating current compressor		A	4.5	5.2	6.8	8.2
Sound power (EN12102)		dB(A)	43	46	49	50
Sound pressure L _{PA} 1m B0/W35 (EN11203)		dB(A)	-5			

¹⁾ EN14511

Heating system					
Max. operating pressure (PS)	bar	6.0			
Max. operating temperature (TS)	°C	100			
Max. operating temperature, condenser	°C	65			
Flow qw nominal: B0/W35, Δt=5K	l/s	0.28	0.39	0.48	0.56
Flow qw minimum: B0/W35, Δt=15K (at max RPS)		0.14	0.20	0.24	0.28

Brine system					
Water volume (V)	l	2.3	2.9	2.9	3.4
Min./Max. operating pressure (PS)	bar	0.2 / 3.0			
Min./Max. operating temperature (TS)	°C	-5 / 20			
Flow qw nominal: B0/W35, Δt=3K	l/s	0.37	0.51	0.64	0.73
Flow qw minimum: B0/W35, Δt=6K (at max RPS)	l/s	0.22	0.31	0.38	0.44
Brine system pump	Class A circulation pump (LEP*)				
Pump capacity	See diagram in the „Installation“ chapter.				

*Low-Energy Pump

Other data					
Refrigerant quantity (R407C, fluorinated greenhouse gases GWP 1774)	kg	1.9	1.9	1.9	2.3
CO2 equivalent	ton	3.370	3.370	3.370	4.080
Compressor oil		FV50S	Polyolester (POE)		
Interrupt value switch HP	MPa	3.1 (31 bar)			
Weight (gross) / Weight (net)	kg	166 / 148	163 / 145	169 / 151	183 / 165
Width x Height x Depth	mm	596 x 775 x 673			
Heat pump Keymark Cert. NO.		012-069	012-063	012-064	012-065

No annual leakage control of the refrigerant is required.

5.2 CTC EcoPart 414-417, 400V 3N~

Electrical data		CTC EcoPart 414	CTC EcoPart 417
Rated electrical data		400V 3N~ 50Hz	
Rated power	kW	6.0	7.4
Rated current	A	12.2	13.9
Max starting current	A	29.1	32.0
Max group fuse	A	13	16
Ingress Protection class (IP)		IP X1	

Operational data for heat pump				
Output from compressor ¹⁾	@ -5/45	kW	11.77	13.70
COP ¹⁾	@ -5/45	-	3.18	3.11
Output from compressor ¹⁾	@ 0/35 0/45 0/55	kW	14.47 13.93 13.40	16.24 16.14 15.87
Input power ¹⁾	@ 0/35 0/45 0/55	kW	3.19 3.83 4.54	3.72 4.47 5.17
COP ¹⁾	@ 0/35 0/45 0/55	-	4.54 3.64 2.95	4.36 3.61 3.07
Output from compressor ¹⁾	@ 5/35 5/45 5/55	kW	16.48 15.98 15.28	19.25 18.42 18.16
COP ¹⁾	@ 5/35 5/45 5/55	-	5.13 4.11 3.28	5.02 4.05 3.38
Max. operating current compressor		A	9.14	11.5
Sound power (EN12102)		dB(A)	53	56
Sound pressure L _{pa} 1m B0/W35 (EN11203)		dB(A)		-5

¹⁾ EN14511

Heating system				
Max. operating pressure (PS)		bar	6.0	
Max. operating temperature (TS)		°C	100	
Max. operating temperature, condenser		°C	65	
Flow qw nominal: B0/W35, Δt=5K		l/s	0.68	0.81
Flow qw minimum: B0/W35, Δt=15K (at max RPS)		l/s	0.34	0.40
Heating medium pump			UPM GEO 25-85	

Brine system				
Water volume (V)		l	4.07	4.07
Min./Max. operating pressure (PS)		bar	0.2 / 3.0	
Min./Max. operating temperature (TS)		°C	-5 / 20	
Flow qw nominal: B0/W35, Δt=3K		l/s	0.88	1.05
Flow qw minimum: B0/W35, Δt=6K (at max RPS)		l/s	0.53	0.63
Brine system pump			Class A circulation pump (LEP*)	
Pump capacity			See diagram in the „Installation“ chapter.	

*Low-Energy Pump

Other data				
Refrigerant quantity (R407C, fluorinated greenhouse gases GWP 1774)		kg	2.7	2.7
CO ₂ equivalent		ton	4.789	4.789
Compressor oil			Polyolester (POE)	
Interrupt value switch HP		MPa	3.1 (31 bar)	
Weight (gross) / Weight (net)		kg	189 / 171	190 / 172
Width x Height x Depth		mm	596 x 775 x 673	
Heat pump Keymark Cert. NO.			012-066	012-067

No annual leakage control of the refrigerant is required.

5.3 CTC EcoPart 406-410, 230V 1N~

Electrical data		CTC EcoPart 406	CTC EcoPart 408	CTC EcoPart 410
Rated electrical data		230V 1N~ 50Hz		
Rated power	kW	2.7	3.4	4.4
Rated current	A	14.0	19.5	21.6
Max starting current	A	30.0	30.0	30.0
Max group fuse	A	16	20	25
Ingress Protection class (IP)		IP X1		

Operational data for heat pump					
Output from compressor ¹⁾	@ -5/45	kW	4.54	6.72	8.07
COP ¹⁾	@ -5/45	-	2.95	3.14	3.15
Output from compressor ¹⁾	@ 0/35 0/45 0/55	kW	5.90 5.48 5.17	8.19 7.87 7.55	9.97 9.55 9.28
Input power ¹⁾	@ 0/35 0/45 0/55	kW	1.29 1.55 1.87	1.79 2.16 2.53	2.17 2.60 3.11
COP ¹⁾	@ 0/35 0/45 0/55	-	4.57 3.54 2.76	4.58 3.64 2.99	4.60 3.68 2.98
Output from compressor ¹⁾	@ 5/35 5/45 5/55	kW	6.81 6.49 6.08	9.44 9.05 8.65	11.42 10.99 10.58
COP ¹⁾	@ 5/35 5/45 5/55	-	5.24 4.15 3.18	5.02 4.04 3.30	5.20 4.16 3.28
Max. operating current compressor		A	13.0	18.5	20.6
Sound power (EN12102)		dB(A)	43	46	49
Sound pressure L _{pa} 1m B0/W35 (EN11203)		dB(A)		-5	

¹⁾ EN14511

Heating system					
Max. operating pressure (PS)		bar	6.0		
Max. operating temperature (TS)		°C	100		
Max. operating temperature, condenser		°C	65		
Flow qw nominal: B0/W35, Δt=5K		l/s	0.28	0.39	0.48
Flow qw minimum: B0/W35, Δt=15K (at max RPS)		l/s	0.14	0.20	0.24

Brine system					
Water volume (V)		l	2.3	2.9	2.9
Min./Max. operating pressure (PS)		bar	0.2 / 3.0		
Min./Max. operating temperature (TS)		°C	-5 / 20		
Flow qw nominal: B0/W35, Δt=3K		l/s	0.37	0.51	0.64
Flow qw minimum: B0/W35, Δt=6K (at max RPS)		l/s	0.22	0.31	0.38
Brine system pump			Class A circulation pump (LEP*)		
Pump capacity			See diagram in the „Installation“ chapter.		

*Low-Energy Pump

Other data					
Refrigerant quantity (R407C, fluorinated greenhouse gases GWP 1774)		kg	1.9	1.9	1.9
CO ₂ equivalent		ton	3.370	3.370	3.370
Compressor oil			FV50S	Polyolester (POE)	
Interrupt value switch HP		MPa	3.1 (31 bar)		
Weight (gross) / Weight (net)		kg	168 / 150	164 / 146	170 / 152
Width x Height x Depth		mm	596 x 775 x 673		
Heat pump Keymark Cert. NO.			012-069	012-063	012-064

No annual leakage control of the refrigerant is required.

5.4 CTC EcoPart 412-414, 230V 1N~

Electrical data		CTC EcoPart 412	CTC EcoPart 414
Rated electrical data		230V 1N~ 50Hz	
Rated power	kW	5.2	6.3
Rated current	A	27.1	33.2
Max starting current	A	30.0	30.0
Max group fuse	A	32	35
Ingress Protection class (IP)		IP X1	

Operational data for heat pump				
Output from compressor ¹⁾	@ -5/45	kW	9.63	11.77
COP ¹⁾	@ -5/45	-	3.17	3.18
Output from compressor ¹⁾	@ 0/35 0/45 0/55	kW	11.75 11.24 10.97	14.47 13.93 13.40
Input power ¹⁾	@ 0/35 0/45 0/55	kW	2.55 3.07 3.71	3.19 3.83 4.54
COP ¹⁾	@ 0/35 0/45 0/55	-	4.60 3.66 2.96	4.54 3.64 2.95
Output from compressor ¹⁾	@ 5/35 5/45 5/55	kW	13.53 12.95 12.57	16.48 15.98 15.28
COP ¹⁾	@ 5/35 5/45 5/55	-	5.11 4.11 3.35	5.13 4.11 3.28
Max. operating current compressor		A	25.0	27.1
Sound power (EN12102)		dB(A)	50	53
Sound pressure L _{PA} 1m B0/W35 (EN11203)		dB(A)	-5	

¹⁾ EN14511:2007, inclusive:

Heating medium pump (EP406/408 - Stratos Tec 25/6 and EP410/412 - Stratos Tec 25/7).

Brine system pump (EP406/410 - Wilo Stratos Para 25/8 and EP412 - Wilo Stratos Para 25/12).

Heating system			
Max. operating pressure (PS)	bar	6.0	
Max. operating temperature (TS)	°C	100	
Max. operating temperature, condenser	°C	65	
Flow qw nominal: B0/W35, Δt=5K	l/s	0.56	0.68
Flow qw minimum: B0/W35, Δt=15K (at max RPS)	l/s	0.28	0.34

Brine system			
Water volume (V)	l	3.4	4.1
Min./Max. operating pressure (PS)	bar	0.2 / 3.0	
Min./Max. operating temperature (TS)	°C	-5 / 20	
Flow qw nominal: B0/W35, Δt=3K	l/s	0.73	0.88
Flow qw minimum: B0/W35, Δt=6K (at max RPS)	l/s	0.44	0.53
Brine system pump		Class A circulation pump (LEP*)	
Pump capacity		See diagram in the „Installation“ chapter.	

*Low-Energy Pump

Other data			
Refrigerant quantity (R407C, fluorinated greenhouse gases GWP 1774)			
CO ₂ equivalent	ton	4.080	4.789
Compressor oil			
Interrupt value switch HP	MPa	3.1 (31 bar)	
Weight (gross) / Weight (net)			
Width x Height x Depth	mm	596 x 775 x 673	
Heat pump Keymark Cert. No.		012-065	012-066

No annual leakage control of the refrigerant is required.

5.5 Component location

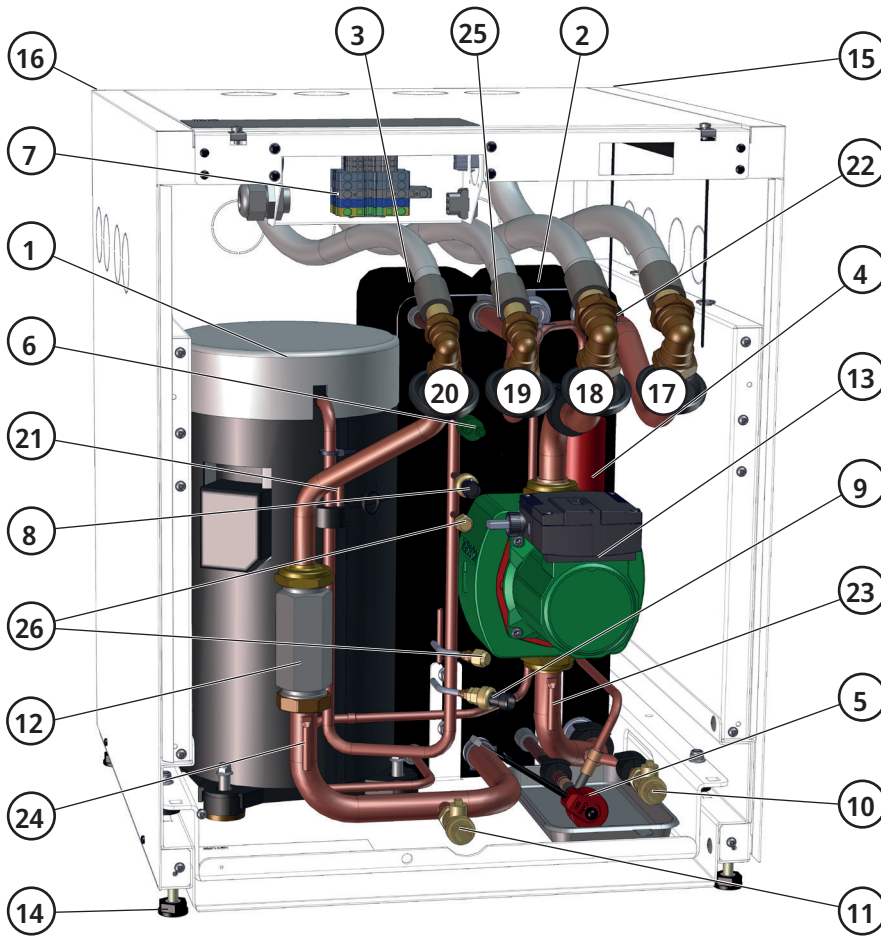

- 1. Compressor
- 2. Evaporator
- 3. Condenser
- 4. Drying filter
- 5. Expansion valve
- 6. High pressure switch
- 7. Terminal board
- 8. High pressure sensor
- 9. Low pressure sensor
- 10. Drain valve cold side/Brine
- 11. Drain valve warm side/Water
- 12. Adapter for pump installation
- 13. Circulation pump cold side
- 14. Adjustable feet
- 15. Conduit for communication cable
- 16. Conduit for mains cable
- 17. Brine in Ø28 mm (from rock)
- 18. Brine out Ø28 mm (to rock)
- 19. Heat medium out Ø22 (CTC EcoPart 406-412)
Heat medium out Ø28 (CTC EcoPart 414-417)
- 20. Heat medium in Ø22 (CTC EcoPart 406-412)
Heat medium in Ø28 (CTC EcoPart 414-417)
- 21. Discharge sensor
- 22. Brine sensor in
- 23. Brine sensor out
- 24. Condenser sensor in
- 25. Condenser sensor out
- 26. Service socket

5.6 Dimensions diagram

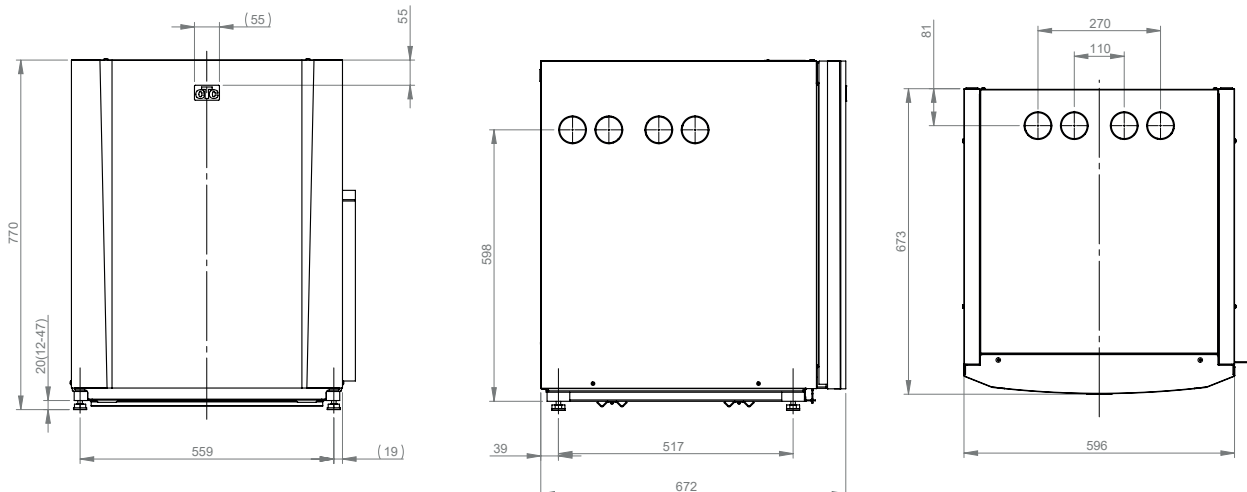

5.7 Refrigerant system

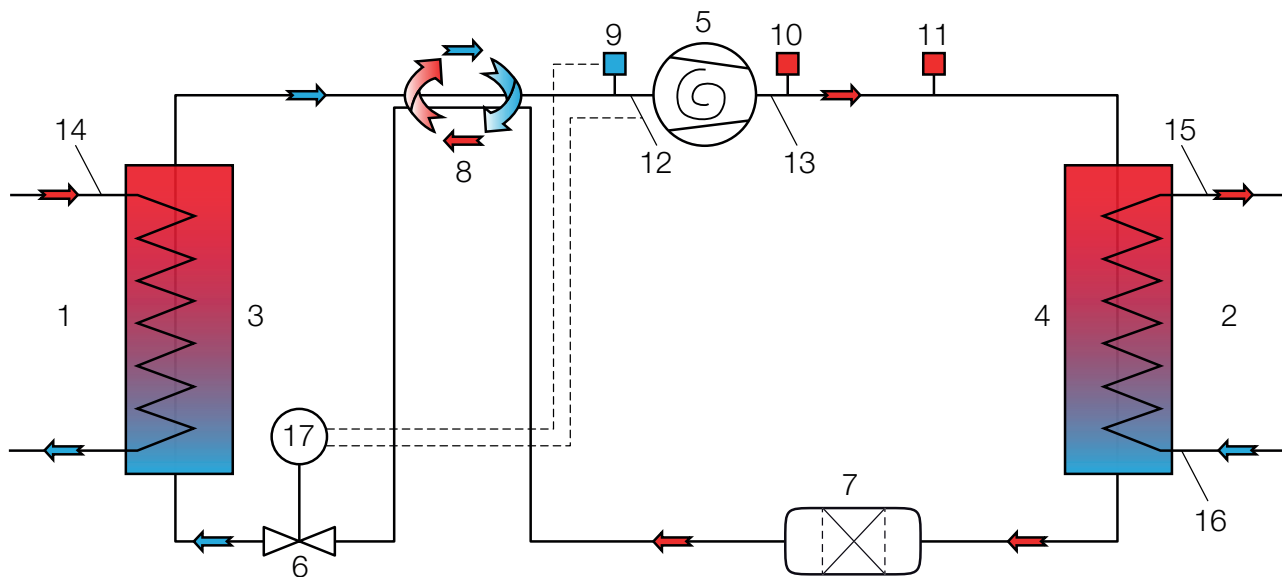

- | | | |
|---------------------------------|-------------------------------|-----------------------------|
| 1. Brine (heat source) | 7. Drying filter | 13. T discharge |
| 2. Water | 8. Refrigerant heat exchanger | 14. T brine |
| 3. Evaporator | 9. Low pressure sensor | 15. T water out |
| 4. Condenser | 10. High pressure sensor | 16. T water in |
| 5. Compressor | 11. High pressure switch | 17. Control expansion valve |
| 6. Expansion valve (electronic) | 12. T suction gas | |

5.8 Operating range

CTC EcoPart's pressure-controlled operations monitoring means that the brine temperature (B) and heat medium temperature (H) can automatically be increased where this is possible.

Operating condition:	B temp/H temp °C
1	-5 / 25
2	20 / 25
3	-5 / 61
4	20 / 64

Operating limits as per the table above are defined in accordance with EN 14511-4.

6. Installation

This section is aimed at anyone responsible for one or more of the installations required to ensure that the product works the way the property owner wants.

Take your time going through functions and settings with the property owner and answer any questions. Both you and the heat pump benefit from a user who has completely understood how the system operates and should be maintained.

The installation must be carried out in accordance with current standards and regulations. Refer to BBR-99 and the Warm and Hot Water Instructions 1993. The product must be connected to an expansion vessel in an open or closed system. Do not forget to flush the heating circuit clean before connection. Apply all the installation settings based on the description in the chapter on "First start".

The heat pump operates with a primary flow/return temperature across the condenser of up to 65/58°C.

Transportation

Transport the unit to the installation site before removing the packaging. Handle the product in the following manner:

- Forklift
- Lifting band around the pallet. NB: Can only be used with the packaging on.

Unpacking

Unpack the heat pump when it is placed next to its installation site. Check that the product has not been damaged in transit. Report any transport damage to the carrier. Also check that the delivery is complete according to the list below.

Delivery includes:

- CTC EcoPart 400 heat pump
- Safety valve 1/2" 3 bar
- Filler manifold
- Brine vessel**
- Rubber grommet D=60
- 2 x Edge mouldings 186 mm
- Communication cable Modbus 5 metres
- Straight connector 28 x G32 ext.*

* Only CTC EcoPart 414-417

** Only CTC EcoPart 406-412

 The product must be transported and stored in an upright position.

6.1 Connection of the heat medium side

Primary flow and return lines must be routed to the heat pump using copper pipes of at least Ø22 mm for CTC EcoPart 406-412. For CTC EcoPart 414-417, copper pipes of at least Ø28 mm must be used. Route the pipes so that no other highest point is present where air can collect and obstruct circulation. If however this cannot be done, provide this highest point with an automatic bleeder.

6.1.1 Circulation pumps (charge pump)

The choice of heat medium pump depends on the type of system. To ensure proper operation the flow in the heat medium circuit should not be less than the value in the table under Technical data. Ensure that the circulation pump is large enough, so that there is sufficient flow through the heat pump. If the flow is too low, there is a risk the high pressure switch will trigger.

The heat medium pump can either be connected to CTC EcoPart 400 (provided it is installed internally) or connected to the product which is used to control it. For internal installation one of the following is normally selected:

CTC EcoPart 406-408	25/70-130 PWM	Prod. no. 587477 303
CTC EcoPart 410-412	25/80-130 PWM	Prod. no. 587477 302
CTC EcoPart 414-417	25/85-130 PWM	Prod. no. 587477 301

6.1.2 Control/supply

CTC EcoLogic Pro

CTC EcoLogic Pro can be connected with up to 10 heat pumps. The heat medium pumps in heat pumps 1 and 2 can then be connected to CTC EcoLogic Pro. Heat medium pumps for heat pumps 3-10 must be installed and connected to CTC EcoPart 400.

CTC EcoLogic v3

The heat medium pump (not speed-controlled) must be connected to CTC EcoLogic v3.

CTC EcoZenith v3

Use a 0-10V pump from CTC or a non speed-controlled pump connected to the CTC EcoZenith.

CTC EcoEl v3

The heat medium pump (not speed-controlled) must be connected to CTC EcoEl v3.

6.1.3 Pump curve, heat medium pump

Grundfos 25/85-130 PWM (CTC EcoPart 414-417)

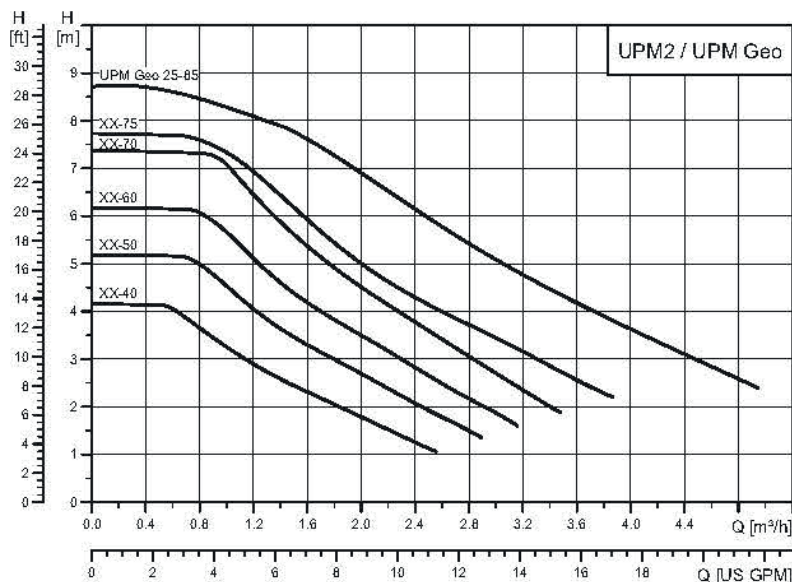

6.2 Connecting the brine system

The brine system, i.e. the ground collector loop, must be assembled and connected by a qualified tradesman in accordance with current regulations and design guidelines.

Extreme care must be taken to ensure that no dirt gets on the collector hoses, which must be washed clean before being connected. The protective caps must remain in place at all times while work is in progress.

The temperature of the brine system can fall below 0 °C. It is therefore important that no water-based lubricants and similar are used during installation. It is also important that all the components are insulated against condensation to prevent the build-up of ice.

Connections

The brine system may be connected to the right, left or top of the heat pump, as well as to its rear. Cut away the cover plate on the side where the brine system is to be connected. The insulation on the inside of the cover plate has been grooved to enable an opening to be cut for the brine hoses provided. When the opening has been made through both the insulation and cover plate, carry out the installation as follows:

1. In order to protect the hoses, fasten the protective edging provided around the edge of the opening in the insulation plate. Adjust the length of the protective edging to suit the opening as required.
2. Pass the hoses through the opening in the side cover plates and connect them. Ensure that the insulation covers all parts of the brine connection to prevent ice and condensation forming.
3. Then install the collector system according to the section "Brine system schematic diagram".

It is also possible to connect the primary flow on one side of the heat pump and the return on the other. Refer to section "Dimensions diagram" for measurements and dimensions. The pipe dimension between the heat pump and brine loop should be not less than $\varnothing 28$ mm.

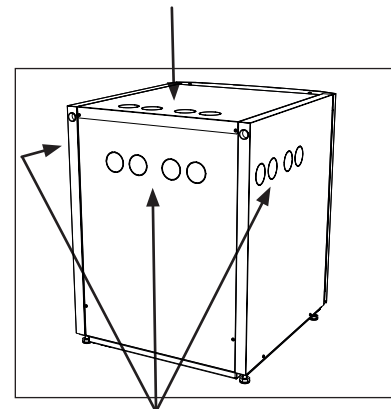

Possible take-offs, Brine hoses

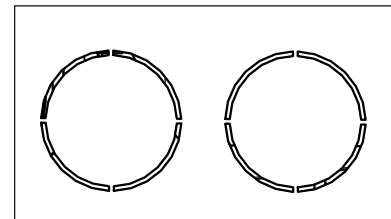

Edging strips (x2), supplied

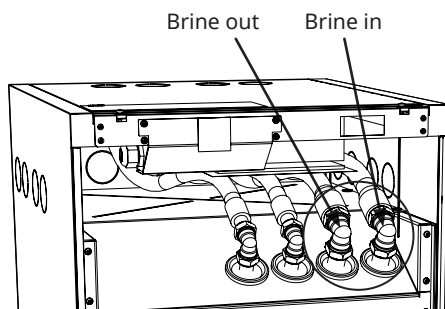

Schematic diagram

The filling equipment is represented by the parts displayed with dashes. NB: Collector hoses must have a bleeding facility as air pockets can occur. Always check the filter (99) when filling and bleeding the brine system.

! The mixing vessel and pump must be of a good size.

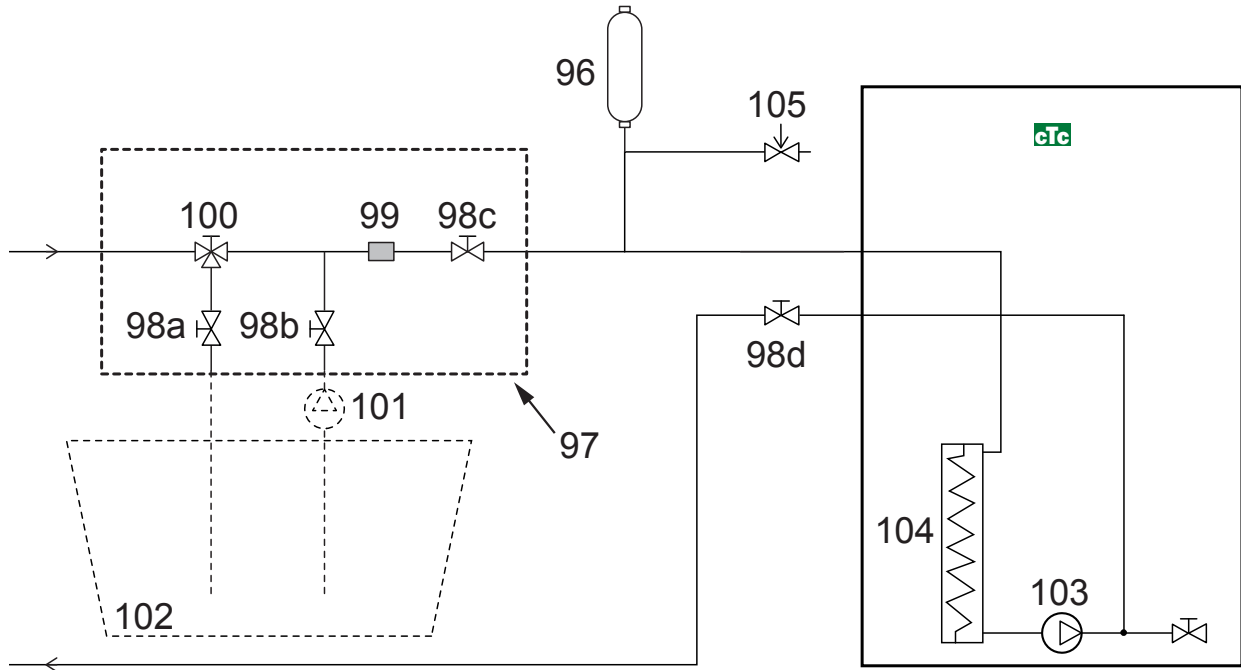

- | | | | |
|-----|------------------------|-----|-----------------------|
| 96 | Level/expansion vessel | 101 | External filling pump |
| 97 | CTC filling kit | 102 | Mixing vessel |
| 98 | Shut-off valve | 103 | Brine pump |
| 99 | Filter | 104 | Evaporator |
| 100 | 3-way valve | 105 | Safety valve 3 bar |

Valves

To facilitate servicing of the cooling unit, shut-off valves must be fitted to both the incoming and outgoing connections. Fit bifurcated valves so that you can fill and bleed the collector circuit later on.

Bleeding

The collector circuit must not contain any air. Even the smallest amount of air can jeopardise the heat pump's operation. See the section Refilling and venting below.

Insulation against condensation

All pipes in the brine system must be insulated against condensation to prevent the possibility of severe build-up of ice and condensation.

Filling and venting

Mix water and antifreeze solution in an open vessel. Connect hoses to the shut-off valves (98a and 98b) as shown in the figure. NB: The hoses must have a minimum diameter of 3/4". Connect a powerful external pump (101) for refilling and bleeding. Then reset the three-way valve (100) and open the valves (98a and 98b) so that the brine passes through the mixing container (102). Also make sure that the valve (98d) is open.

For start-up of the brine pump, see the relevant manual for the CTC EcoPart's controller.

Allow the brine to circulate in the system for a long period of time until it is completely free of air. There could still be air in the system, even though no air accompanies the liquid out. Reset the 3-way valve (100) so that any remaining air can come out.

Bleed the level vessel (96) by loosening the plug on the top of the level vessel.

Now close the valve (98a) while the filling pump continues to run. The filling pump (101) now pressurises the system. Also close the valve (98b) and shut off the filling pump.

If the level in the level vessel is too low, close the valves (98c) and (98d). Unscrew the plug and fill the vessel to around 2/3 full. Screw the plug back in and open the valves (98c) and (98d).

6.3 Brine pump

The circulation pumps in CTCs products are of the energy efficiency class A.

- CTC EcoHeat 406-408 has pump 25-70 180.
- CTC EcoHeat 410-412/CTC EcoPart 410-417 & CTC GSi 12 has pump 25-125 180.

25/70-180, 1x230V, 50/60Hz

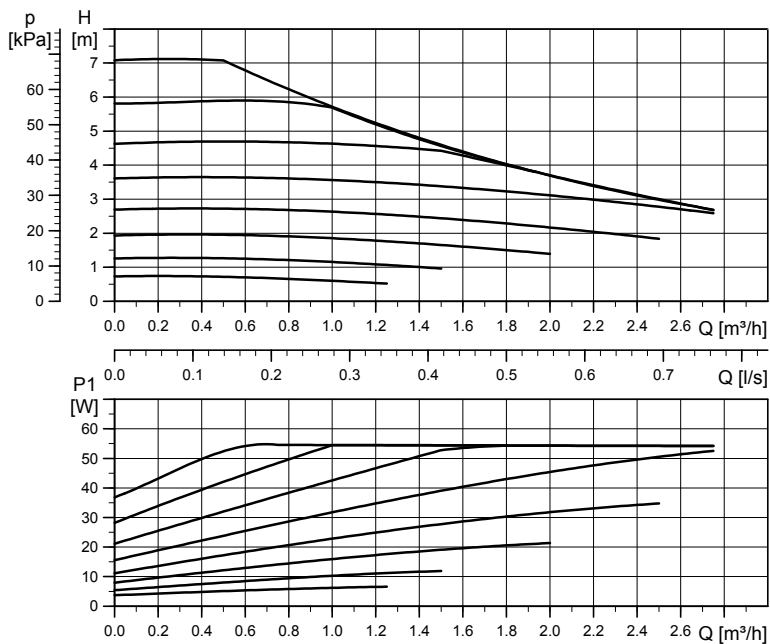

25/125-180 PWM, 1x230V, 50/60Hz

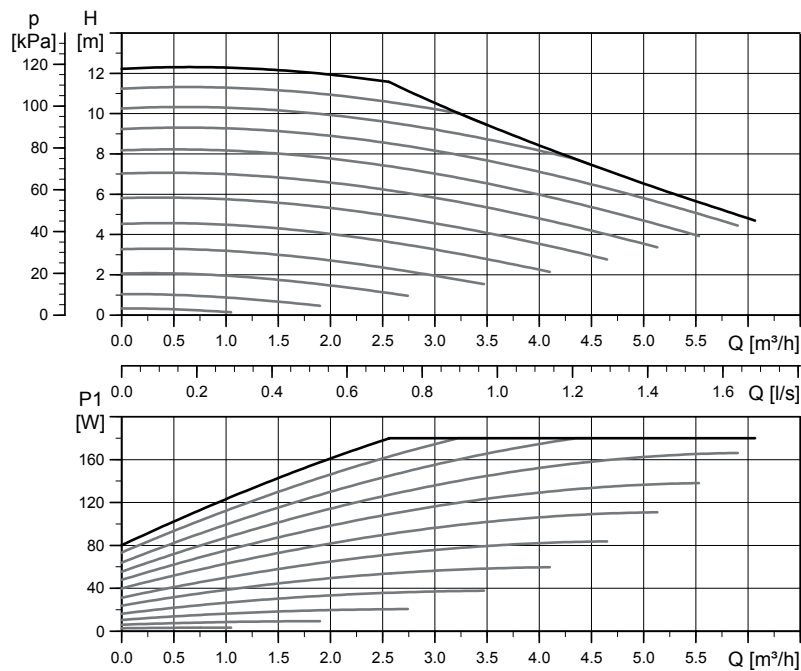

Post-installation check on brine system

After a few days, you must check the fluid level in the vessel. Fill if necessary and close the valves (98c and 98d) when filling.

Level vessel/Expansion vessel

The level vessel should be fitted to the incoming line from the borehole or ground loop, at the system's highest point. Bear in mind that the tank can produce condensate on its exterior. Fit the safety valve (105) as shown in the schematic diagram and fit a suitable plug to the top of the vessel.

If the vessel cannot be fitted at the highest point, a closed expansion vessel must be fitted.

Filling kit with dirt filter

Arrows on the valve housing indicate the flow direction. Close valves (98c and 100) when cleaning the filter. Unscrew the filter cap and flush the filter clean. When refitting, the pin under the filter holder should be fed into the designated hole in the filter housing. Top up with a little brine, if necessary, before fitting the cap. The filter should be checked and cleaned after a short period of operation.

Brine

The brine circulates in a closed system. The fluid consists of water and antifreeze solution. Sentinel R500 & R500C are recommended for use in the brine circuit. The glycol is mixed at a concentration of slightly less than 30%, which is equivalent to fire risk class 2b and a freezing point of around -15°C.

It is a CTC recommendation that around 1 litre of brine/glycol is required per metre of collector hose, i.e. around 0.3 litres of antifreeze solution will be needed per metre of hose, for a hose diameter of 40 mm.

Air pockets

To avoid air pockets, make sure that the collector hoses constantly rise towards the heat pump. If this is not possible, it must be possible to bleed the system at the high points. The filling pump usually manages smaller local height discrepancies.

Checking brine difference

When the heat pump is running, regularly check that the temperature difference between incoming and outgoing brine temperatures is not too large. If there is a large difference, one of the causes may be due to air in the system or a blocked filter. If this is the case, the heat pump triggers the alarm.

The alarm factory setting is 7°C, but 9°C is permitted for the first 72 hours while the compressor is running, as microbubbles in the system can reduce brine flow.

 Check the dirt filter after bleeding has been completed.

 The fluid must be thoroughly mixed before the heat pump is started.

7. Electrical installation

Installation and heat pump connection must be performed by an authorised electrician. All wiring must be installed according to applicable provisions.

7.1 Electrical installation 400V 3N~

CTC EcoPart 400 must be connected to 400V 3N~ 50Hz and protective earth.

When connecting to CTC EcoZenith i250/i255, the power rating of the electric boiler must also be allowed for, as CTC EcoPart 400 is supplied with power via CTC EcoZenith i250/i255.

The size of the group fuse is specified under "Technical Data".

The connection to the CTC EcoPart 400 is made using a 5-conductor cable which provides the heat pump with electric power for the compressor (400V 3N~) and brine pump (230V 1N~).

Power supply cable fitted, 200 cm.

Omnipolar safety switch

The installation should be preceded by an omnipolar safety switch according to overvoltage category III, which ensures disconnection from all electric power sources.

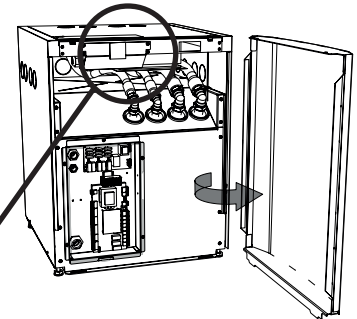
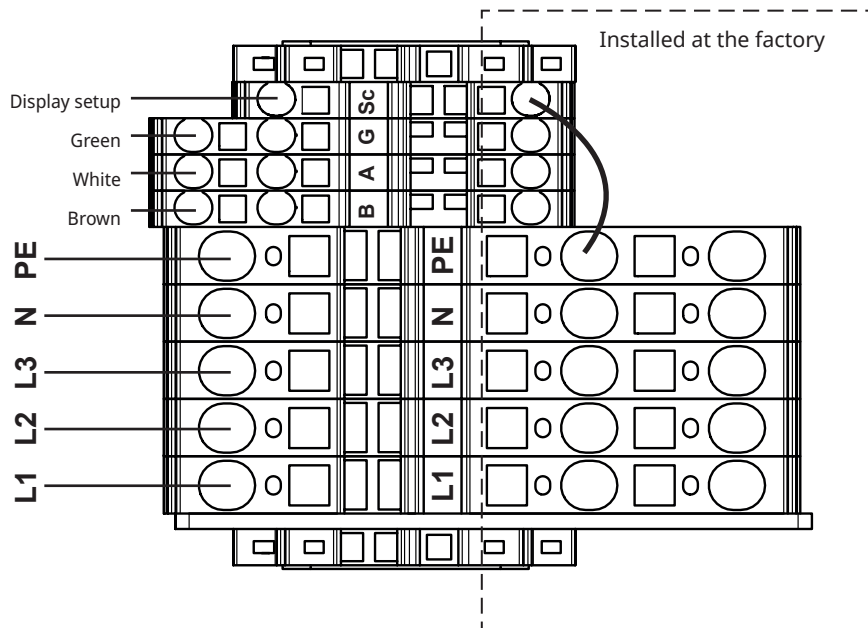

7.2 Electrical installation 230V 1N~

The CTC EcoPart 400 must be connected to 230V 1N~ 50Hz and protective earth.

When connecting to CTC EcoZenith i250/i255, the power rating of the electric boiler must be allowed for, as CTC EcoPart 400 is supplied with power via CTC EcoZenith i250/i255.

Connection to CTC EcoPart 400 is made using a 3-core cable, which provides the heat pump with electricity for the compressor (230V 1N~) and brine pump (230V 1N~).

Power supply cable fitted, 200 cm.

Safety switch

The installation should be preceded by an omnipolar safety switch which ensures disconnection from all electric power sources.

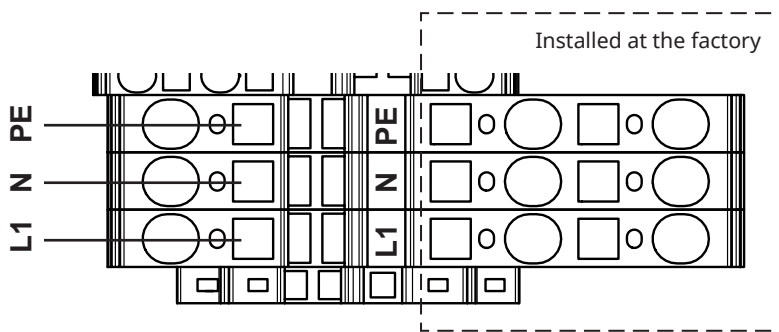

7.3 Alarm output

The CTC EcoPart is provided with a potential-free alarm output which is activated if any alarm is active in the heat pump. This output may be connected to a maximum load of 1A 250V AC. An external fuse should also be used. Cable approved for 230V AC must be used for connecting this output, irrespective of the load that is connected. For connection information, see the wiring diagram.

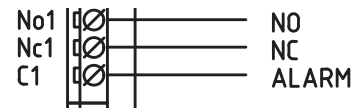

Close-up from wiring diagram.

7.4 Groundwater heating

Groundwater can also be used as a heat source for CTC's heat pumps. The groundwater is pumped up to an intermediate heat exchanger that transfers the energy to the brine liquid. It is important that an intermediate heat exchanger is installed in the system. The intermediate heat exchanger prevents the product's evaporator from becoming damaged due to deposits from groundwater particles and minerals, which could otherwise involve expensive work on the product's refrigerant system. Water requirements analysis should always be undertaken for intermediary heat exchangers. Local regulations and permit requirements must be taken into account. The return water is discharged elsewhere, to a drilled return flow well or similar.

Also pay attention to the intermediary heat exchanger supplier's instructions.

The brine pump and groundwater pump must be connected to run simultaneously in order to prevent freezing.

8. Communication connection

When connecting the CTC EcoPart 400 to products with different control systems, accessories are sometimes needed to control the products. The various alternatives available are described in this section.

The supplied LiYCY (TP) cable, which is a 4-core shielded cable with braided communication core, must be used as the communication cable.

Use of any other cable will mean that the conductor colours may not match, necessitating a check that the colours of the conductors from the controlling unit are connected to the same colours in the heat pump. The product may also be more sensitive to faults if the wrong cable is used.

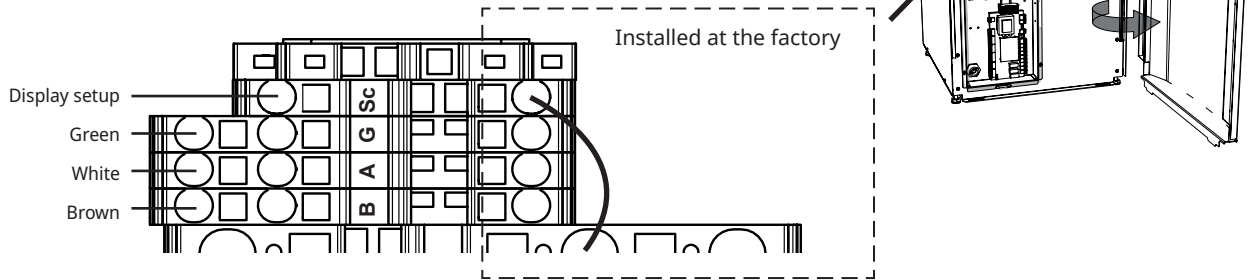

8.1 CTC Basic Display (accessory)

Given that CTC EcoPart 400 does not have its own control, the CTC Basic Display accessory is required.

- When connecting more than one heat pump to CTC EcoLogic M/L or CTC EcoZenith i555 Pro, the CTC Basic Display accessory can be used to address the various heat pumps A1, A2, A3, and so on.

For connection, see the manual for the CTC Basic Display.

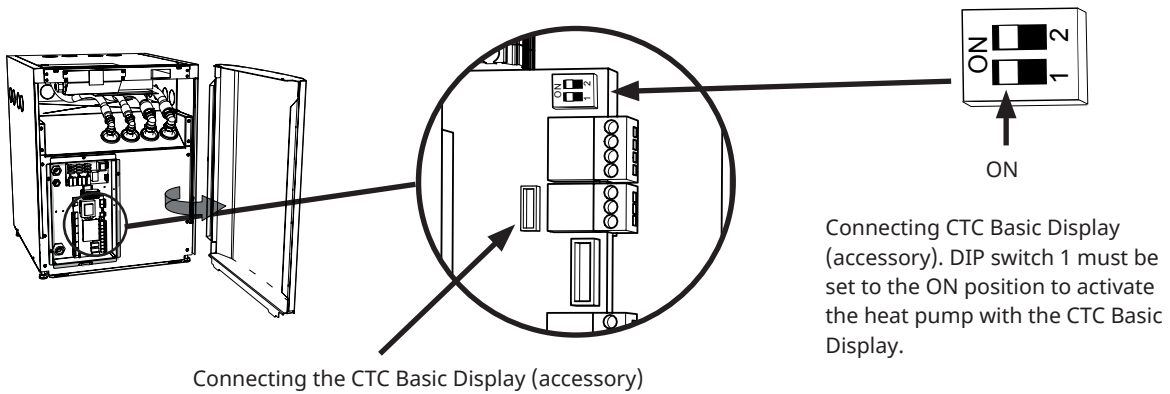

8.2 Option 1 – Connection of one heat pump

When connecting CTC EcoPart 400 to CTC EcoZenith i255, CTC EcoZenith i555 Pro, CTC EcoZenith i360, CTC EcoVent i360F or CTC EcoLogic Pro/Family, the communication cable (LiYCY (TP)) must be connected directly to the respective product. When installing only one heat pump, make sure that DIP switch 2 is in the ON position.

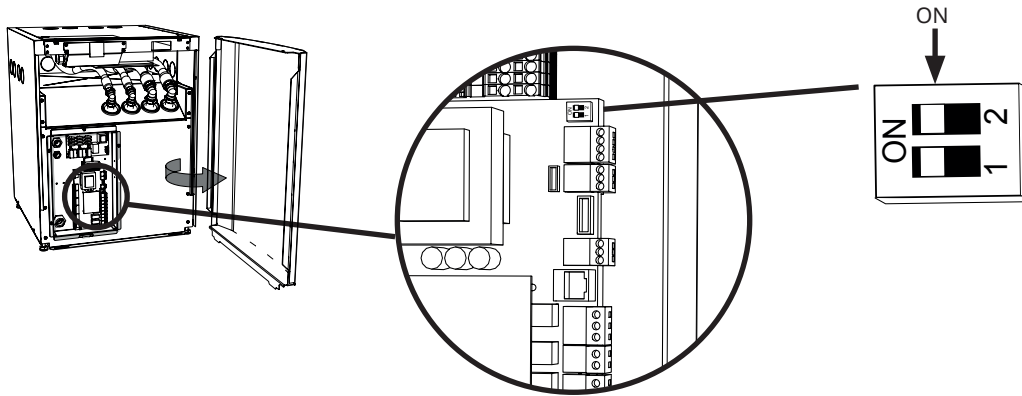

8.3 Option 2 – Series connection of heat pumps

When connecting more than one heat pump to CTC EcoLogic M/L or CTC EcoZenith i555 Pro, the CTC Basic Display accessory can be used to address the various heat pumps A1, A2, A3, and so on. All CTC EcoPart 400 units are factory-set addressed to A1. For connection, refer to the CTC Basic Display manual.



CTC Basic Display (accessory)

When connected in series, the shielding of the communication cable on the last heat pump must be connected to earth and the heat pump itself must be terminated. This is done by making sure DIP switch 2 is in the ON position on the heat pump that is to be terminated.

The loop which connects position Sc of the control terminal block and PE on the mains terminal block must be removed on all heat pumps in the series connection except the last and replaced by the shielding, which is then connected up to the next heat pump (control terminal block position Sc).

! When connected in series, the last heat pump must be set to terminated position.

Heat pumps in series connection

CTC Basic Display

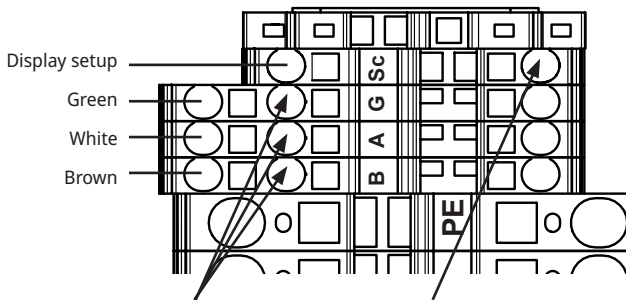
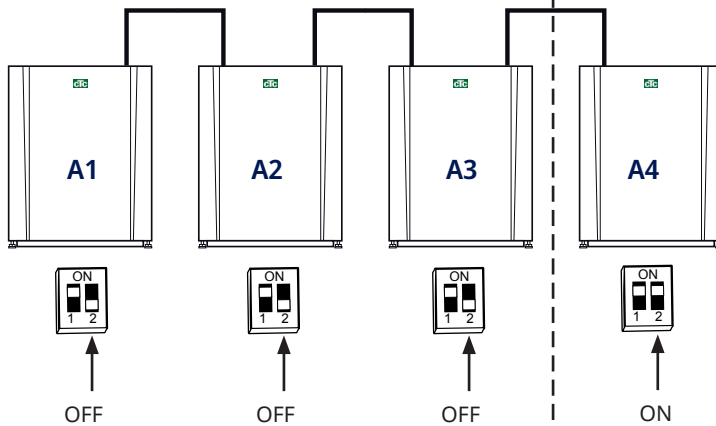

Connect each cable to the next heat pump in the series connection here.

Remove the loop; connect the shielding to the next heat pump here.

The last heat pump connected in series

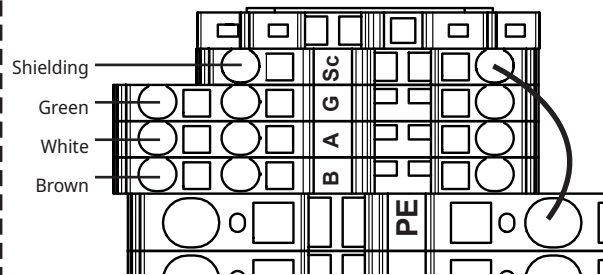
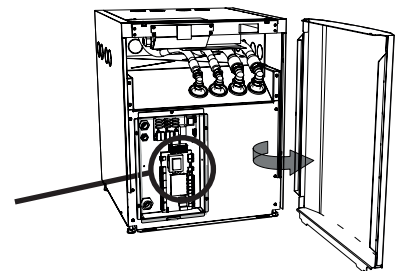

Make sure DIP switch 2 is in the ON position on the last heat pump in the series connection.

The loop should be left in place.

8.4 Option 4 – CTC EcoEI v3

When connecting products with different control systems (version 3 (v3) and version 4 (v4)), the CTC Converter accessory will be needed to interpret the signals between the two products. For connection, see the manual for the CTC Converter.

A CTC EcoEI may only be connected to a CTC EcoPart 406-412.

! Version 3 (v3) relates to models manufactured from 2006 onwards.

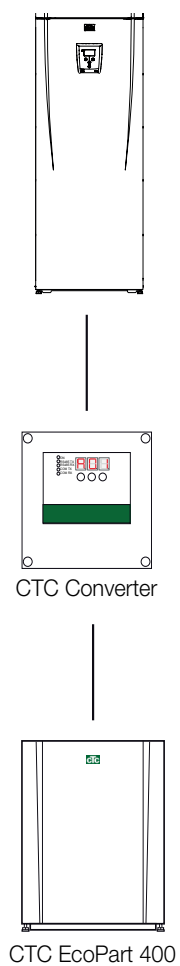

8.5 Option 5 – CTC EcoZenith i550 v3

When connecting products with different control systems (version 3 (v3) and version 4 (v4)), the CTC Converter accessory will be needed to interpret the signals between the two products. For connection, see the manual for the CTC Converter.

The CTC EcoZenith v3 is available in two different variants. An earlier variant with only one communication port, and a later one with three such ports.

The earlier one will have a serial number starting from:

Serial no.	Item no.	Model
7250-1222-0138	583700001	CTC EcoZenith i550 3x400V
7250-1222-0168	584892001	CTC EcoZenith i550 3x230V
7250-1222-0171	584890001	CTC EcoZenith i550 BBR
7250-1222-0171	584893001	CTC EcoZenith i550 1x230V

The later one will have a serial number starting from:

Serial no.	Item no.	Model
7250-1222-0139	583700001	CTC EcoZenith i550 3x400V
7250-1222-0169	584892001	CTC EcoZenith i550 3x230V
7250-1222-0172	584890001	CTC EcoZenith i550 BBR
7250-1222-0172	584893001	CTC EcoZenith i550 1x230V

! Version 3 (v3) relates to models manufactured from 2006 onwards.

! If new (version 4) and old (version 3) heat pumps are combined in an installation, the new ones must be addressed using the lowest numbers of A1, A2.

! When connected in series, the last heat pump must be set to terminated position.

Early model with one input

Connect the CTC EcoPart 400 through the CTC Converter accessory. The CTC EcoPart 400 can then be connected in series to up to three CTC EcoPart 400 units.

The connected heat pumps must then be addressed using the CTC Basic Display accessory.

Later model with three inputs

Connect the CTC EcoPart 400 through the CTC Converter accessory. Connect the heat pumps to separate inputs. These do not need to be addressed since they are all factory-set addressed to A1.

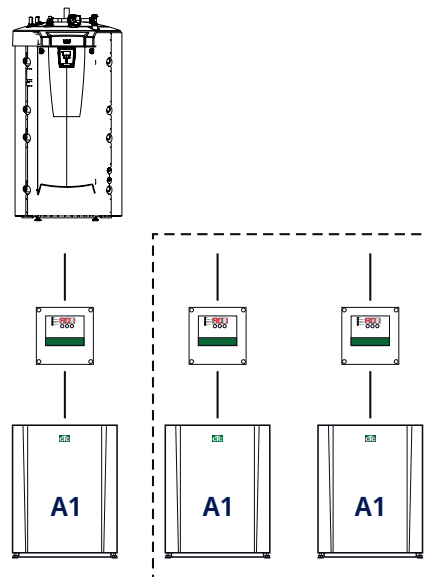
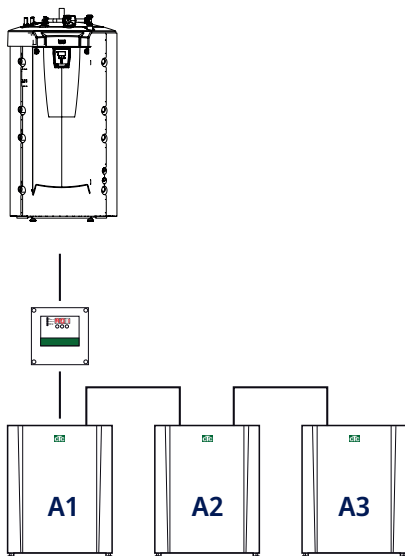

8.6 Option 6 – CTC EcoLogic v3

When connecting products with different control systems (version 3 (v3) and version 4 (v4)), the CTC Converter accessory will be needed to interpret the signals between the two products.

CTC EcoPart 400 can then be connected in series with up to three products. The connected heat pumps must be addressed using the CTC Basic Display accessory. For connection, see the manual for the CTC Converter.

! Version 3 (V3) relates to models manufactured from 2006 onwards.

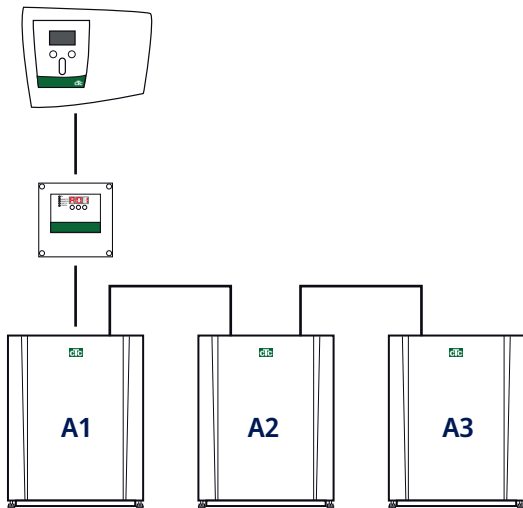

8.7 Connecting the control system

8.7.1 Define number of heat pumps

Define the heat pumps in the controlling product's display under: "Advanced/Define system/Heat pump".

Set the heat pumps contained in the system to position "On".

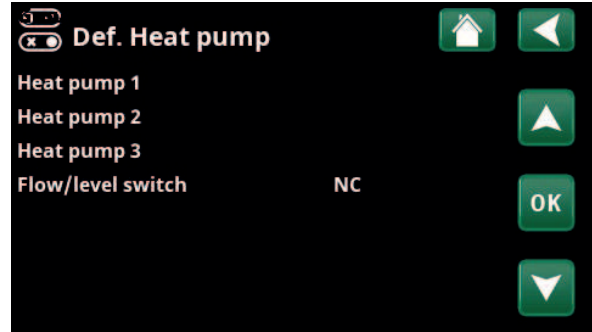

Example of a system with 3 heat pumps.

8.7.2 Numbering CTC EcoPart 400 as HP2

Applies to control launched in October 2020 with 3 connectors on the back of the display. 2 x RJ-45 and 1 x RJ-12.

NOTE! For displays with 2 connectors, see "Numbering CTC EcoPart 400 as A2".

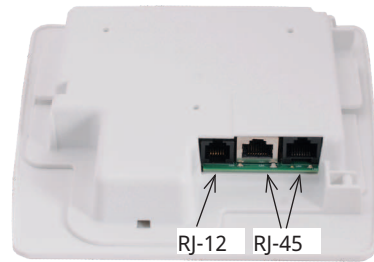

1. System disconnected from power.

2. Power up the control (CTC EcoLogic or CTC EcoZenith i555 Pro) as well as the CTC EcoPart 400, which will be numbered as Heat Pump 2 (HP2).

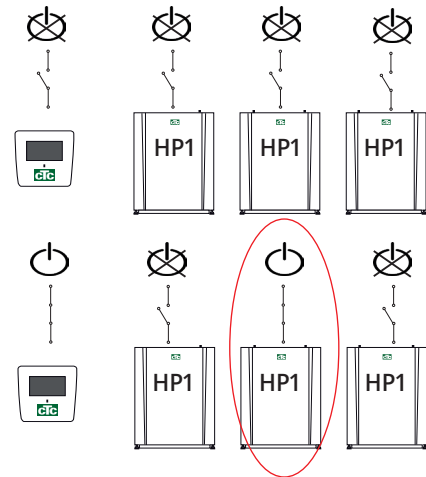

3. Wait for about 2 minutes.

4. Go to "Installer/Service/Set Address".

Select "Actual address", press OK and press the down arrow until the current heat pump appears (HP1) Press OK.

Select "New address", press OK and use the arrow to scroll up and down until the actual address of the heat pump is shown (HP2). Press OK.

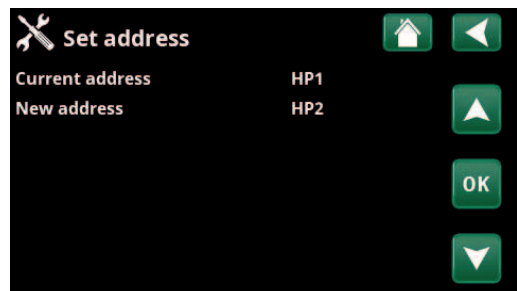

5. The heat pump is now numbered (HP2).

When you press OK, (HP1 and HP3)* disappears and the row "Actual address/New Address" will go dark.

**In this example, we have assumed that the heat pump is called HP1, which is the factory default. If the heat pump has already been renumbered, then select this number instead.*

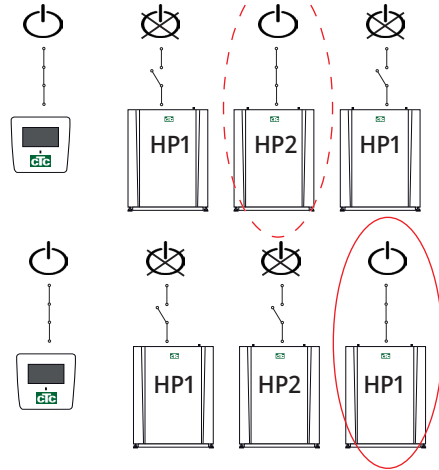
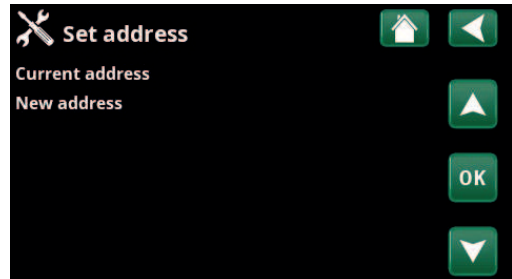

6. Number the other heat pumps:

Power up the next heat pump, which will be numbered heat pump 3 (HP3).

7. Wait 2 minutes.

8. Go to "Service/Set Address".

Select "Actual address", press OK and press the down arrow until the current heat pump appears (HP1) Press OK.

Select "New address", press OK and press the up arrow until the actual address of the heat pump is shown (HP3). Press OK.

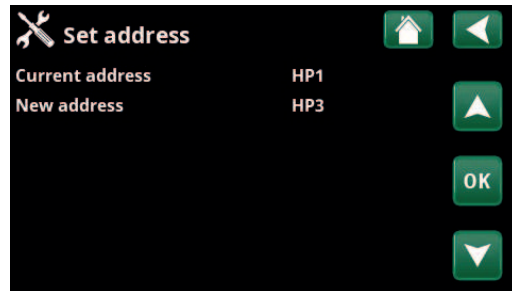

9. The heat pump is now numbered (HP3).

When you press OK, (HP1 and HP3)* disappears and the row "Actual address/New address" will go dark.

**In this example, we have assumed that the heat pump is called HP1, which is the factory default. If the heat pump has already been renumbered, then select this number instead.*

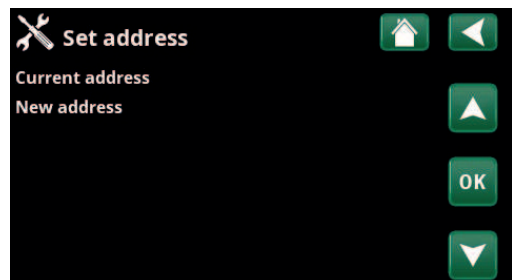

10. Redo the procedure according to the number of heat pumps to be numbered.

When all heat pumps are numbered and powered up, they should be displayed when you press the heat pump symbol in the menu "Operation data". If any heat pump does not appear in the menu (communication with the heat pump fails) It may be because it has not been numbered as described above.

If you do not know the name of the heat pump, you can reset the numbering by using the "Select/Rename Heat Pump" menu (refer to points 9 and 10 above) to indicate all possible names of the heat pump, i.e. you select and confirm HP1 and then HP2 up to HP10 to ensure that the correct name is given.

Finally, test that the respective heat pump starts via the "Installer/Service/Function test/Heat pump" menu.

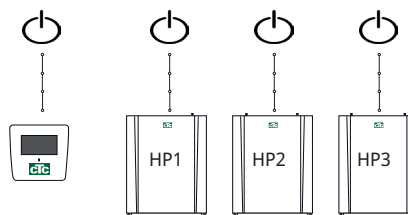

8.7.3 Good to know when setting an address

Error set Address

The heat pump could not be found and numbered.

The heat pump was not what it was supposed to be called.

No communication with the heat pump.

Check that the heat pump is powered up.

If the address setting fails, the latest heat pump addresses remain. In this example HP1 and HP2.

Make sure the heat pump is powered up.

Try again with a new actual address.

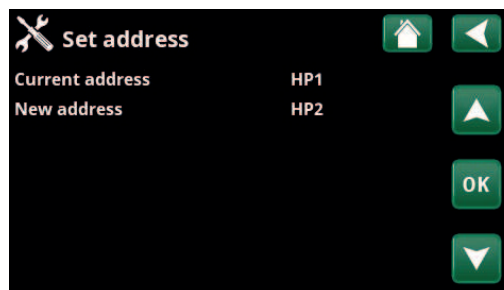
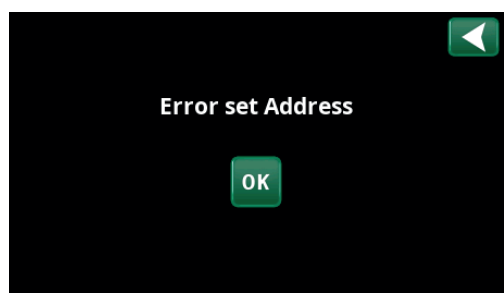

8.7.4 Numbering CTC EcoPart 400 as A2

Applies to older controls with 2 connectors on the back of the display.

1 x RJ-45 and 1 x RJ-12 for the CTC EcoZenith i550 Pro and CTC EcoLogic Pro/Family.

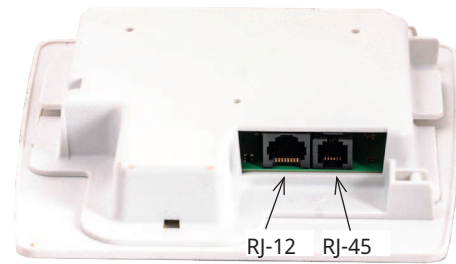

1. System disconnected from power.

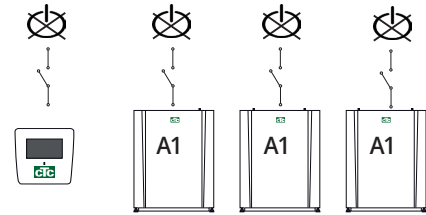

2. Power up the control (CTC EcoLogic Pro or CTC EcoZenith i550 Pro) as well as CTC EcoPart 400 to be numbered as Heat Pump 2 (A2).

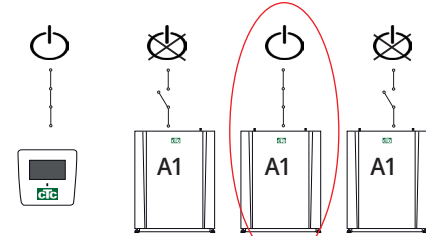

3. Wait approx. 2 minutes until the heat pump is visible in the "Operation data" menu.

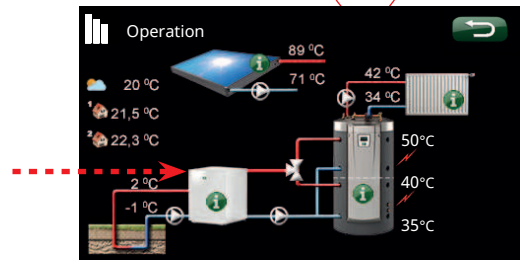

4. Go to "Installer/Settings/Heat pump 2" and the row "Select/Rename Heat pump". Press OK.

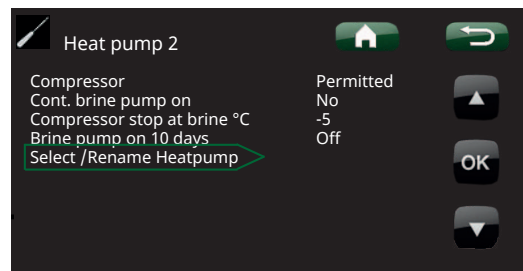

5. Press the arrow up until (A1)* is displayed. Press OK.

After pressing OK, (A1)* disappears and the "Select/Rename Heat Pump" row will go dark.

**In this example, we have assumed that the heat pump is called A1, which is the factory default. If the heat pump has already been renumbered, then select this number instead.*

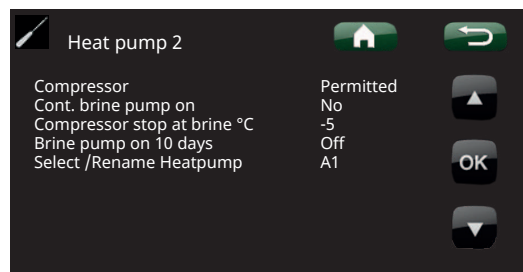

6. The heat pump is now numbered (A2).

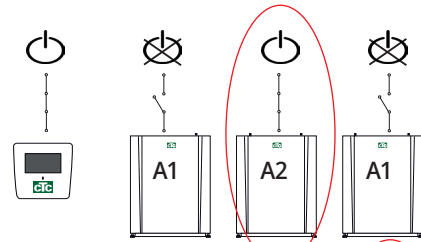

7. To number the other heat pumps:

Energise the control and the next heat pump to be numbered to heat pump 3 (A3).

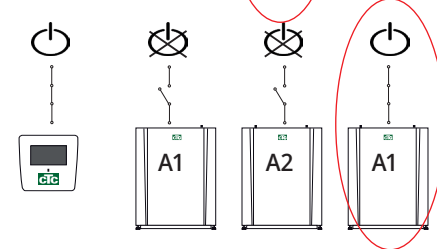

8. Wait approx 2 minutes until the heat pump is visible in the operational information.

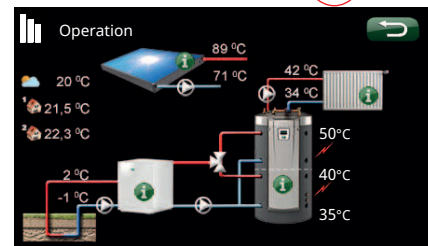

9. Go to "Installer/Settings/Heat pump 3" and the row "Select/Rename Heat pump". Press OK.

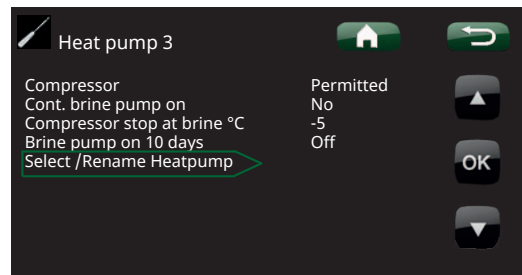

10. Press the arrow up until (A1)* is displayed. Press OK.

After pressing OK, (A1)* disappears and the "Select/Rename Heat Pump" row will go dark. The heat pump is now numbered (A3).

**In this example, we have assumed that the heat pump is called A1, which is the factory default. If the heat pump has already been renumbered, then select this number instead.*

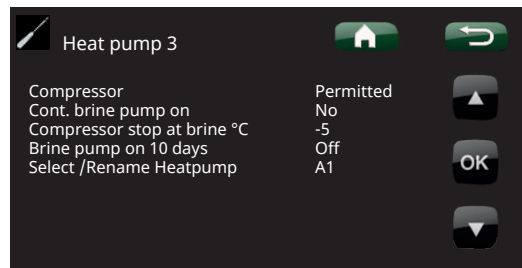

11. Redo the procedure according to the number of heat pumps to be numbered.

When all heat pumps are numbered and powered up, they should be displayed when you press the heat pump symbol in the menu "Operation data". If any heat pump does not appear in the menu (communication with the heat pump fails) It may be because it has not been numbered as described above.

If you do not know the name of the heat pump, you can reset the numbering by using the "Select/Rename Heat Pump" menu (refer to points 9 and 10 above) to indicate all possible names of the heat pump, i.e. you select and confirm A1 and then A2 up to A10 to ensure that the correct name is given.

Finally test in the menu "Advanced/Service/Function test/Heat pump" that the respective heat pump starts.

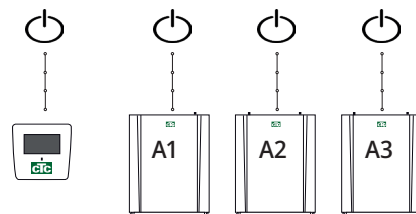

8.8 Wiring diagram 400V 3N~

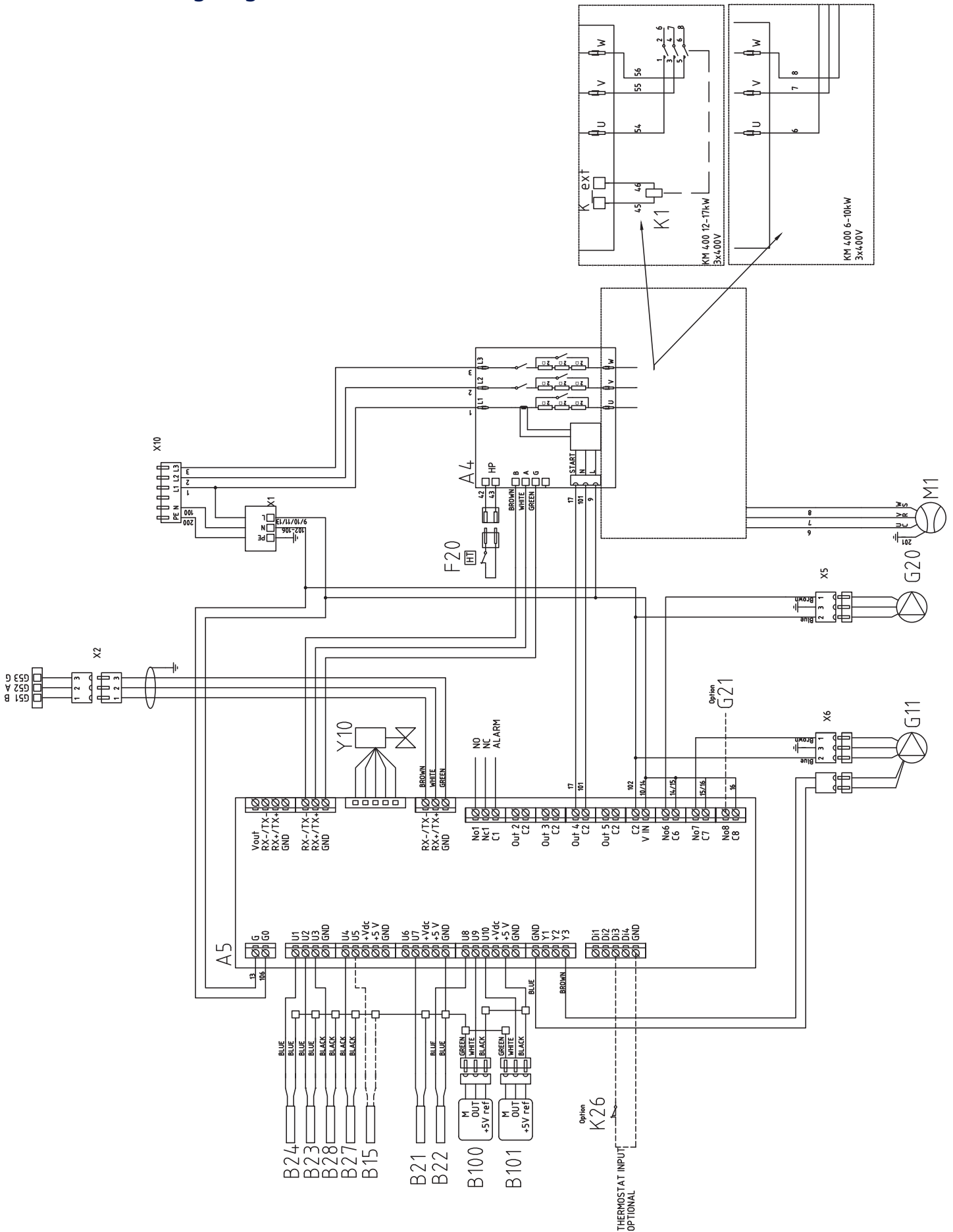

8.9 Wiring diagram 230V 1N~

WITH NET 3x230V
PHASE L2 = (N)

LOOK AT ELECTRICAL DIAGRAM CONTROL UNIT

KM2
-10kW
-12kW

KM1
-14kW

CONNECTION TERMINALS
IN COOLING MODULE

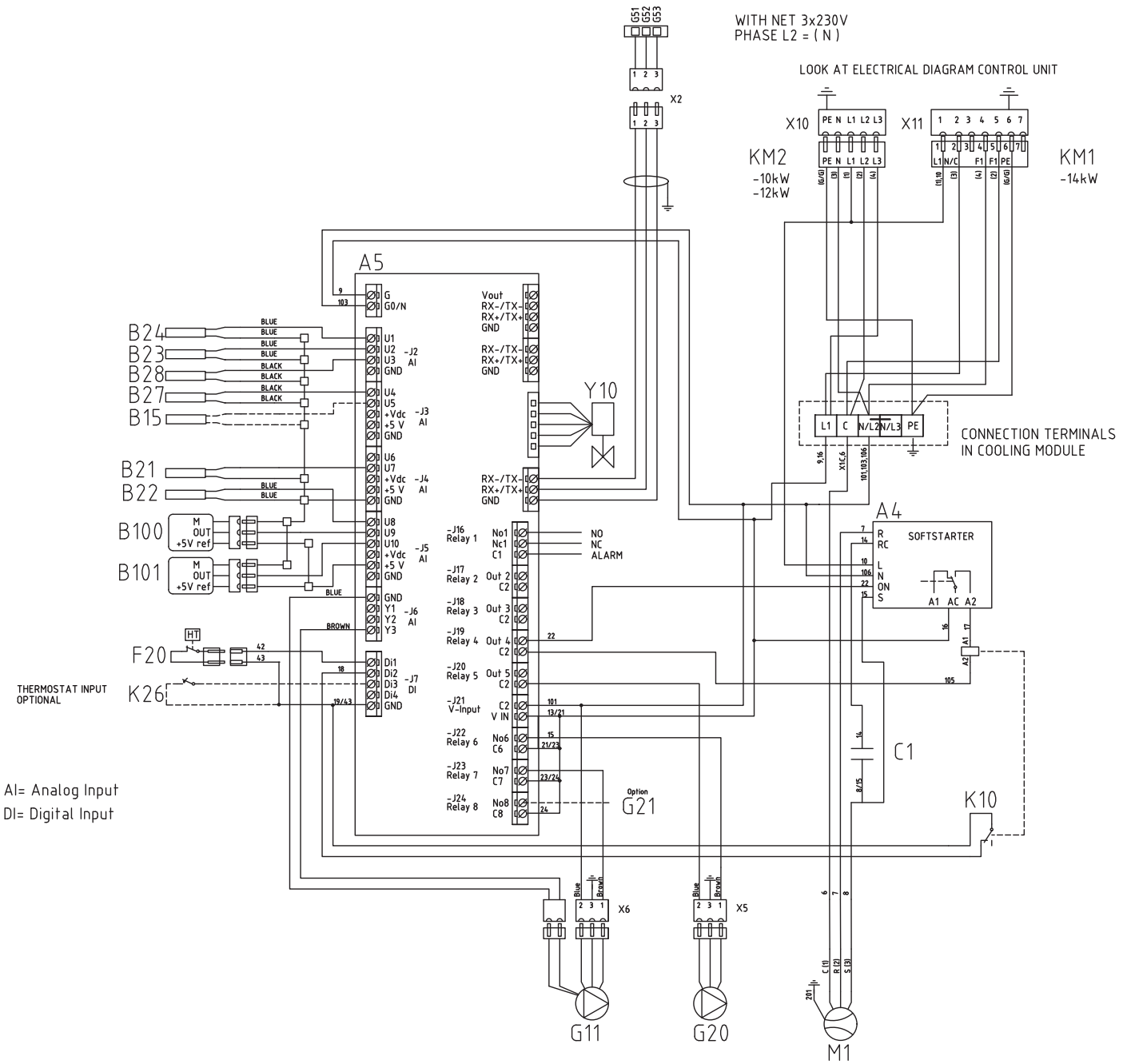

AI= Analog Input
DI= Digital Input

8.10 Parts list

A4	Soft-start card with motor protection and contactor function	
A5	HP control card	
B21	Discharge gas sensor	Type 3/ NTC 50
B22	Suction gas sensor	Type 2/ NTC 015
B23	Brine sensor in	Type 1/ NTC 22
B24	Brine sensor out	Type 1/ NTC 22
B27	HP in	Type 2/ NTC 22
B28	HP out	Type 2/ NTC 22
B100	High pressure sensor	
B101	Low pressure sensor	
C1	Capacitor, compressor	
F20	High pressure switch	
G11	Charge pump	
G20	Brine pump	
G21	Groundwater pump, signal 230V, option	
K1	Contactor	
K10	Relay (1-phase)	
K26	Thermostatic control, option	
M1	Compressor	
X1	Terminal block	
X10	Terminal block	
Y10	Expansion valve	

8.11 Resistances for sensors

Temp °C	Sensor Type 1 NTC Resistance kΩ	Temp °C	Sensor Type 2 NTC Resistance kΩ	Temp °C	Sensor Type 3 NTC Resistance kΩ	Temp °C	NTC 50 Resistance kΩ
100	0.22	100	0.67	130	5.37	150	0.89
95	0.25	95	0.78	125	6.18	145	1.00
90	0.28	90	0.908	120	7.13	140	1.14
85	0.32	85	1.06	115	8.26	135	1.29
80	0.37	80	1.25	110	9.59	130	1.47
75	0.42	75	1.47	105	11.17	125	1.67
70	0.49	70	1.74	100	13.06	120	1.91
65	0.57	65	2.07	95	15.33	115	2.19
60	0.7	60	2.5	90	18.1	110	2.5
55	0.8	55	3.0	85	21.4	105	2.9
50	0.9	50	3.6	80	25.4	100	3.4
45	1.1	45	4.4	75	30.3	95	3.9
40	1.3	40	5.3	70	36.3	90	4.6
35	1.5	35	6.5	65	43.6	85	5.4
30	1.8	30	8.1	60	52.8	80	6.3
25	2.2	25	10	55	64.1	75	7.4
20	2.6	20	12.5	50	78.3	70	8.8
15	3.2	15	15.8	45	96.1	65	10.4
10	4	10	20	40	119	60	12.5
5	5	5	26	35	147	55	15
0	6	0	33	30	184	50	18
-5	7	-5	43	25	232	45	22
-10	9	-10	56	20	293	40	27
-15	12	-15	74	15	373	35	33
-20	15	-20	99	10	479	30	40
-25	19	-25	134	5	619	25	50
-30	25	-30	183			20	62
						15	78
						10	99
						5	126

Temp °C	NTC 22 kΩ Resistance Ω	Temp °C	NTC 150 Resistance Ω	Temp °C	NTC 015 Resistance Ω
130	800	70	32	40	5830
125	906	65	37	35	6940
120	1027	60	43	30	8310
115	1167	55	51	25	10000
110	1330	50	60	20	12090
105	1522	45	72	15	14690
100	1746	40	85	10	17960
95	2010	35	102	5	22050
90	2320	30	123	0	27280
85	2690	25	150	-5	33900
80	3130	20	182	-10	42470
75	3650	15	224	-15	53410
70	4280	10	276	-20	67770
65	5045	5	342	-25	86430
60	5960	0	428		
55	7080	-5	538		
50	8450	-10	681		
45	10130	-15	868		
40	12200	-20	1115		
35	14770	-25	1443		
30	18000	-30	1883		
25	22000	-35	2478		
20	27100	-40	3289		
15	33540				
10	41800				
5	52400				
0	66200				
-5	84750				
-10	108000				
-15	139000				
-20	181000				
-25	238000				

9. First start

1. Check that the heating boiler and system are full of water and have been bled.
2. Check that all connections are tight.
3. Check that sensors and the radiator pump are connected to the power source.
4. Energise the heat pump by switching on the safety switch (the main switch).

Once the system has heated up, check that all connections are tight, the various systems have been bled, heat is coming out into the system and DHW is coming out at the tap locations.

10. Operation and Maintenance

When the installer has installed your new heat pump, you should check along with the installer that the system is in perfect operating condition. Let the installer show you where the power switches, controls and fuses are so that you know how the system works and how it should be maintained. Bleed the radiators (depending on type of system) after around three days of operation and top up with water if required.

10.1 Periodic maintenance

After three weeks of operation and every three months of the first year, thereafter once a year:

- Check that the installation is free of leaks.
- Check that the product and system are free of air; bleed if needed – see the section Connecting the brine system.
- Check that the brine system is still pressurised and that the fluid level in the brine vessel is adequate/correct.
- The products do not require annual inspection for refrigerant leakage.

10.2 Operation stop

The heat pump is shut down using the operating switch. If there is a risk of the water freezing, drain out all the water from the CTC EcoPart 400.

10.3 Service position

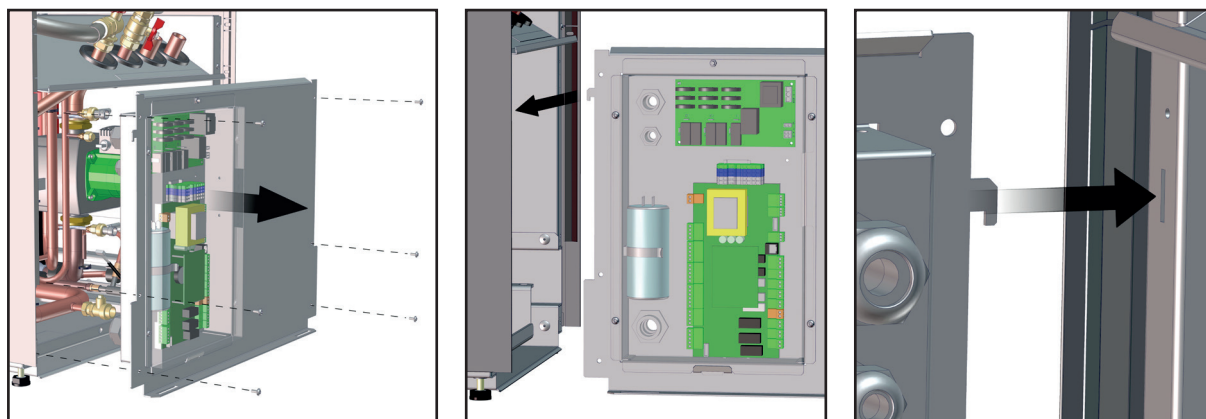

11. Troubleshooting

The CTC EcoPart 400 is designed to provide reliable operation and high levels of comfort, as well as have a long service life. Various tips are given below which may be helpful and guide you in the event of an operational malfunction.

If a fault occurs, you should always contact the installer who installed your unit.

If the installer believes the malfunction is due to a materials or design fault, then they will contact CTC AB to check and rectify the issue. Always enter the product serial number.

11.1 Air problems

If you hear a rasping sound from the heat pump, check that it is properly bled.

Top up with water where required, so that the correct pressure is achieved. If this noise recurs, call a technician to check the cause.

11.2 Alarm

Any alarms and information texts from the CTC EcoPart 400 are displayed in the product which is used to control it; you should therefore consult the manual for that product.



012



CTC AB Box 309 SE-341 26 Ljungby
info@ctc.se +46 372 88 000
www.ctc.se