



Installation and Maintenance Manual
CTC EcoZenith i555 Pro
3x400V / 1x230V / 3x230V



Translation of the original instructions.
Keep for future use.
Read carefully before use.

Table of contents

1.	Congratulations on buying your new product!	3	16.	Transportation, unpacking and installation	117
2.	Safety instructions	4	16.1	Transportation.....	117
3.	Important to consider!	6	16.2	Unpacking.....	117
4.	Checklist	7	16.3	Fitting rear insulation and plastic top cover.....	117
5.	House heating settings	8	17.	Parts list	119
6.	Technical data	11	18.	Schematic diagram	120
7.	Measurements	12	19.	Pipe installation	121
8.	Design	13	19.1	Heating circuit.....	123
8.1	Main components.....	13	19.2	Heat pump.....	124
9.	Function of CTC EcoZenith i555 Pro	14	19.3	Solar heating.....	125
9.1	Heating Circuit.....	15	19.4	DHW.....	126
9.2	DHW.....	16	19.5	Wood boiler.....	127
9.3	Heat pump.....	17	19.6	Buffer tanks.....	128
9.4	Wood boiler.....	20	19.7	Additional boiler.....	129
9.5	Additional boiler (pellets, oil, gas, electricity).....	21	19.8	Pool.....	130
9.6	Solar Energy.....	22	19.9	CTC EcoZenith – CTC EcoComfort (Cooling).....	131
9.7	Recharging borehole/ground.....	23	20.	Electrical installation	132
9.8	External DHW tank.....	24	20.1	Positioning of electrical components.....	133
9.9	Pool.....	24	20.2	Omnipolar safety switch.....	134
9.10	External buffer tank.....	25	20.3	Heat pump power supply.....	134
9.11	Cooling CTC EcoComfort.....	27	20.4	Communication between the CTC EcoZenith and CTC EcoAir/CTC EcoPart.....	134
10.	DHW	30	20.5	Low voltage 230 V/400 V (High voltage).....	134
11.	Display settings	32	20.6	Sensor (Safety Extra-Low Voltage (SELV)).....	144
11.1	Start page.....	32	20.7	Current sensor connection.....	148
11.2	Installation wizard.....	33	20.8	Settings to be carried out by the installation electrician..	149
11.3	Heating/Cooling.....	34	20.9	Installing a backup power supply.....	149
11.4	DHW.....	37	21.	Installation of optional immersion heater	150
11.5	Ventilation.....	37	22.	Installation of additional boiler	151
11.6	Schedule.....	38	23.	Electrical diagram	152
11.7	Operation data.....	40	23.1	Wiring diagram relay board 3x400V.....	152
12.	Advanced	54	23.2	Wiring diagram relay board 1x230V.....	153
12.1	Display.....	54	23.3	Wiring diagram relay board 3x230V.....	154
12.2	Settings.....	56	23.4	Wiring diagram for expansion board.....	155
12.3	Define.....	82	23.5	Parts list, Wiring diagram.....	156
12.4	Cascade connection.....	94	23.6	Resistances for sensors.....	157
12.5	Service.....	102	24.	Installation, Communication	158
13.	Parameter list CTC EcoZenith i555	108	24.1	Fitting the ethernet cable.....	159
14.	Operation and Maintenance	110	24.2	Remote - Screen Mirroring.....	160
15.	Troubleshooting	111	24.3	myUplink.....	161
15.1	Information messages.....	112	25.	First start	162
15.2	Alarm messages.....	113	25.1	Before first start.....	162
15.3	Critical alarms - Risk of freezing.....	116	25.2	First start.....	162

Software update



software.ctc.se

EN

For more information on updated functions and downloading the latest software, see the website "software.ctc.se".

1. Congratulations on buying your new product!



You have just purchased a CTC EcoZenith i555 Pro, with which we hope you will be very pleased. Read about how you can take care of your product on the following pages. One part contains general information and one part has been written for the installer. Save this manual containing the installation and maintenance instructions. You will be able to enjoy the benefits of your CTC EcoZenith for many years, and this manual provides all the information you will need.

The Complete System

CTC EcoZenith i555 Pro is a complete system able to meet your home's heating and hot water requirements. It is equipped with a unique control system that monitors and controls your entire heating circuit regardless of how you choose to tailor it.

CTC EcoZenith i555 Pro has a control system that:

- monitors all DHW and heating circuit functions;
- monitors and controls your heat pump, solar collectors, additional heat, buffer tank, pool, etc.;
- allows for individual settings;
- indicates desired values, for instance, temperatures and energy consumption;
- facilitates settings in a simple and structured manner.

Your CTC EcoZenith i555 Pro has built-in finned copper coils which provide plenty of hot water and another finned copper coil to handle the heat from solar collectors. The product also has a so-called cellar heat feature during the summer and a floor feature which maximises the primary flow temperature.

Using the integrated night reduction function, you can set and change the temperature in the property during a 24-hour period, day by day, in blocks or as a vacation function.

Service-friendly

Easily accessible electrical components, along with effective troubleshooting functions in the control program, make the CTC EcoZenith easy to service. It is supplied with a room sensor as standard, which is equipped with LED lights that flash in the event of a fault.

CTC EcoZenith is fully ready for connection to:

Ground source heat pumps:

- CTC EcoPart 400 series
- CTC EcoPart 600M series

Air source heat pumps:

- CTC EcoAir 400 series
- CTC EcoAir 510M 230V 1N~
- CTC EcoAir 520M 230V 1N~
- CTC EcoAir 614M and CTC EcoAir 622M
- CTC EcoAir 700M series

CTC EcoZenith can also be connected to solar collectors, water jacketed stoves and any additional boilers.

2. Safety instructions



The installation should be preceded by an omnipolar safety switch according to overvoltage category III, which ensures disconnection from all electric power sources.

Turn off the power with an omnipolar switch before doing any work on the product.



The product must be connected to protective earth.



The product is classified as IP X1. The product must not be rinsed with water.

The product must not be started if it is not filled with water; instructions are in the "Pipe installation" section.



When handling the product with a hoist ring or similar device, make sure that the lifting equipment, eyebolts and other parts are not damaged. Never stand under the hoisted product.



Never jeopardise safety by removing bolted covers, hoods or similar.

WARNING: Do not switch on the product if there is a possibility that the water in the heater is frozen.

If these instructions are not followed when installing, operating and maintaining the system, CTC's commitment under the applicable warranty terms is not binding.



Any work on the product's cooling system should be carried out by authorised personnel only.

Installation and connection in the product must be carried out by a authorised electrician. All piping must be installed according to the applicable requirements.

Service of the product's electrical system must only be carried out by a qualified electrician in compliance with the specific requirements of the national standard for electrical safety.

Replacement of damaged supply cable, must be carried out by the manufacturer or qualified service engineer to avoid risk.

Safety valve check:

-Safety valve for boiler/system to be checked regularly.

This device can be used by children from the age of eight years and above and by people with reduced physical, sensory or mental ability or lack of experience or knowledge if they have been taught, either with supervision or with the instructions provided, how to use the device safely and understand the risks involved. Children should not play with the device. Cleaning and maintenance should not be carried out by children without supervision.

Cyber security UK

This information extends to England, Wales, Scotland and Northern Ireland.

CTC AB meets the applicable security requirement in Schedule 1 according to The Product Security and Telecommunications

Infrastructure (Security Requirements for Relevant Connectable Products) Regulations 2023.

The defined support period in terms of security update is three years from the date of manufacture.

The date of manufacturer is found in the serial number, placed on the product.

xxxxYYWWxxxx

YY = Year

WW = Week

If a suspected software security issue or flaw has been discovered,

scan the QR code to get to the reporting page or visit <https://ctc-heating.com/cyber-security> to report.



3. Important to consider!

Check the following points at the time of delivery and installation:

- CTC EcoZenith i555 Pro must be transported and stored in an upright position. When moving the product, it can be placed temporarily on its back.
- Remove the packaging and check before installation that the product has not been damaged in transit. Report any transport damage to the carrier.
- Place CTC EcoZenith i555 Pro on a solid foundation, preferably made of concrete. If the product needs to be placed on a soft carpet, base plates must be placed under the adjustable feet.
- Remember to leave a service area of at least 1 metre in front of the product. Space is also needed around the product for installation of insulation and plastic top cover, see the "Transportation, Unpacking and Installation" chapter. CTC EcoZenith i555 Pro must not be lowered beneath floor level.
- Check for missing parts.
- The product must not be installed where the ambient temperature is higher than 60°C.
- CTC EcoAir 510M 230V 1N~ and CTC EcoAir 520M 400V 3N~ must have software version HP control board 20160401 or later.
- Register the product for warranty and insurance via the website <https://www.ctc-heating.com/customer-service#warranty-registration>

Scope of delivery

Standard delivery

- Multitank CTC EcoZenith i555 Pro
- Additional package with:
 - Installation and Maintenance Manual
 - Outdoor sensor
 - Room sensor
 - Safety valve 9 bar (tap water)
 - Safety valve 2.5 bar (heating circuit)
 - Drainage valve
 - Adapter between the drainage valve and the connection sleeve
 - Sensor, 2 off (primary flow and return)
 - Cover washer for connections, upper and lower tank, 8 off
 - Cover washer for solar coil connections, 2 off
 - Insulation for connection sleeves that are not used
 - Sensor labelling
 - Screw 4.2 x 14 graphite grey (x25 + 2 spare)
 - Screw 4.2 x 14 zinc grey (x4 + 2 spare)
- Additional package with rear insulation sections and plastic top.

 Information in this type of box [i] is intended to help ensure that the product functions optimally.

 Information in this type of box [!] is particularly important for correctly installing and using the product.

Fill in the information below. It may come in useful if anything should happen.

Product:	Manufacturing number:
Installer:	Name:
Date:	Tel. no.:
Electrical installer:	Name:
Date:	Tel. no.:

No liability is accepted for any misprints. We reserve the right to make design changes.

4. Checklist

The checklist must always be completed by the installation engineer

- If a service is performed, you may be required to provide this document.
- Installation must always be done according to the installation and maintenance instructions.
- Installation must always be carried out in a professional manner.

Following installation, the unit must be inspected and functional checks performed as indicated below:

Pipe installation

- The CTC EcoZenith is filled, positioned and adjusted according to the instructions.
- The CTC EcoZenith is positioned so that servicing is possible.
- Capacity of the charge/radiator pump (depending on type of system) for the flow required.
- Open radiator valves and other relevant valves.
- Tightness test.
- Bleed the system.
- Check the functions of the required safety valves.
- Waste pipe connected to floor drain.

Electrical installation

- Compressor, direction of rotation (if heat pump installed).
- Power switch.
- Correct wiring.
- Requisite sensors for selected system.
- Outdoor sensor.
- Room sensor (optional).
- Accessories.
- The CTC EcoZenith activated and started.
- Electric power and fuse, adapted for the property, in normal operation and backup mode.

Customer information (adapted to the relevant installation)

- Start-up together with the customer.
- Menus/controls for selected system.
- Installation and Maintenance Manual handed over to the customer.
- Check and filling, heating circuit.
- Fine-tuning information, heat curve.
- Alarm information.
- Mixing valve.
- Safety valve function test.
- Review warranty terms and conditions with the customer.
- Register your Installation certificate at ctc-heating.com.
- Information on fault reporting procedures.

Date/Customer

Date/Installer

5. House heating settings

The House Heating Curve

The heating curve is the central part of the product's control system. It is the heating curve which determines the compensated flow temperature requirements for your property dependent upon the outdoor temperatures. It is important that the heating curve is correctly adjusted, so that you achieve the best operation and economy possible.

One property requires a radiator temperature of 30 °C when the outdoor temperature is 0 °C, whilst a different property requires 40 °C. The difference between different properties is determined by the radiator surface area, the number of radiators and how well insulated the house is.

Adjusting the heating curve

In the "Heating curve" menu under "Settings/Heating circuit", you can fine adjust the values of the heating curve for the primary flow temperature in relation to the outdoor temperature in the graph, as well as set the values for curve inclination and curve adjustment for the heating circuit.

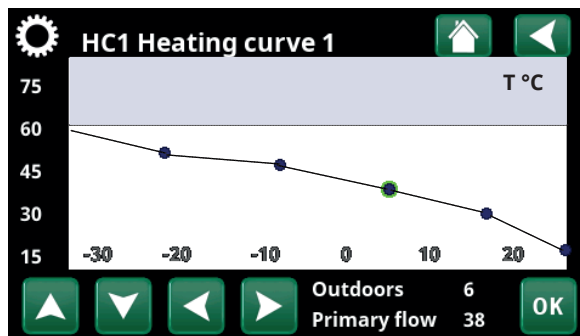

Menu: "Advanced/Settings/Heating Circuit/Heating Circuit 1/Heating curve/Fine adjustment".

i For more information on how to set the heating curve, see section "Heating curve" in chapter "Settings / Heating circuit".

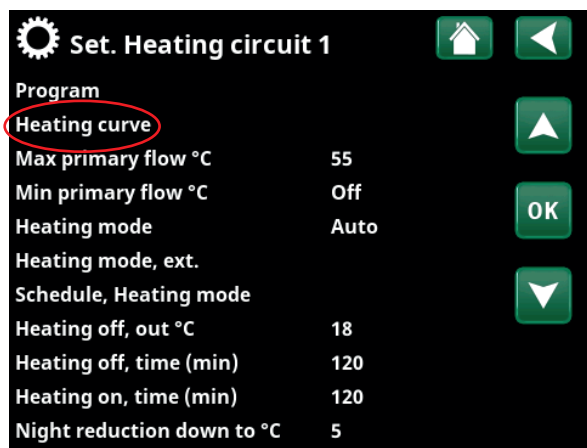

Part of the "Advanced/Settings/Heating Circuit/Heating Circuit 1" menu.

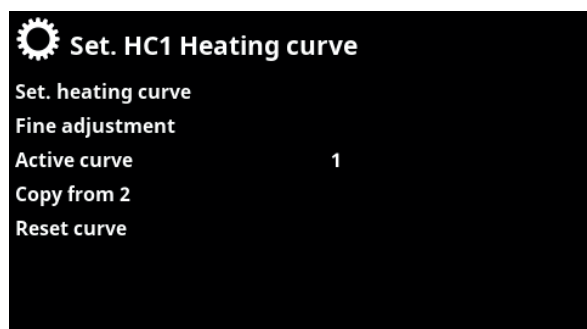

Menu: "Advanced/Settings/Heating Circuit/Heating Circuit 1/Heating curve". Active curve: #1.

During the adjustment period it is important that:

- the night reduction function is not selected.
- all thermostat valves on the radiators be fully opened. (This is to find the lowest curve for the most economical use of the heat pump).
- the outdoor temperature is not higher than +5 °C.
- the radiator system is operational and correctly adjusted between different circuits.

Appropriate Default Values

During installation you can seldom achieve a precise setting for the heating curve instantly. In this case, the values given below may provide a good starting point. Radiators with small heat-emission surfaces require a higher primary flow temperature.

Floor heating only:	Inclination 35
Low temperature system: (well insulated houses)	Inclination 40
Normal temperature system: (factory setting)	Inclination 50
High temperature system: (older houses, small radiators, poorly insulated)	Inclination 60

Ask your installer to help you set these values.

It is extremely important to set the heating curve and, in some cases, unfortunately, this process may take several weeks. The best way of doing this, upon the initial start-up, is to select operation without any room sensor. The system then operates using the outdoor temperature reading and the property's heating curve only.

Adjusting the heating curve

The method described below can be used to adjust the heating curve correctly.

Adjustment if it is too cold indoors:

- If the outdoor temperature is **lower** than 0 °C: Increase the Inclination value by a couple of degrees. Wait 24 hours to see if any further adjustment is required.
- If the outdoor temperature is **higher** than 0 °C: Increase the Adjustment value by a couple of degrees. Wait 24 hours to see if any further adjustment is required.

Adjustment if it is too warm indoors:

- If the outdoor temperature is **lower** than 0 °C: Decrease the Inclination value by a couple of degrees. Wait 24 hours to see if any further adjustment is required.
- If the outdoor temperature is **higher** than 0 °C: Decrease the Adjustment value by a couple of degrees. Wait 24 hours to see if any further adjustment is required.

i The set heating curve always takes priority. The room sensor can only increase or decrease the heat beyond the set heating curve to a certain extent. Where operating without a room sensor, the selected heating curve determines the flow temperature supplied to the radiators.

Examples of Heating Curves

You can see in the diagram below how the heating curve changes with different Inclination settings. The gradient of the curve shows the temperatures that the radiators require at different outdoor temperatures.

Curve inclination

The inclination value which is set is the primary flow temperature when the outside temperature is -15 °C.

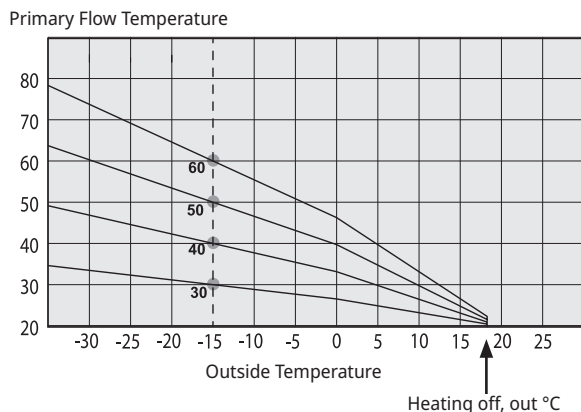

Curve adjustment

The curve can be parallel displaced (adjusted) by the desired number of degrees to adapt to different systems/houses.

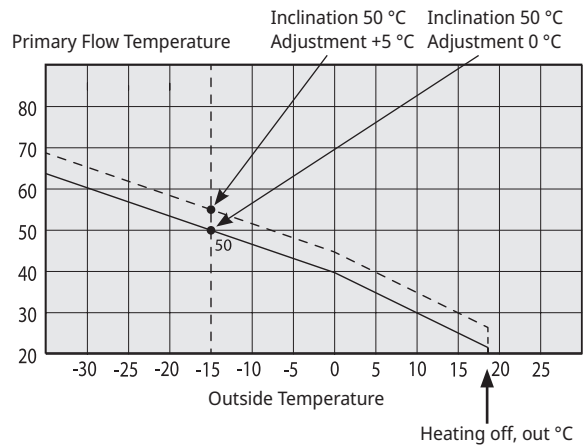

Example

Curve inclination 60 °C
Curve adjustment 0 °C

In this example, the maximum outgoing primary flow temperature is set at 55 °C. The minimum permitted primary flow temperature is 27 °C (e.g. summer-time basement heating or the floor circuits in a bathroom).

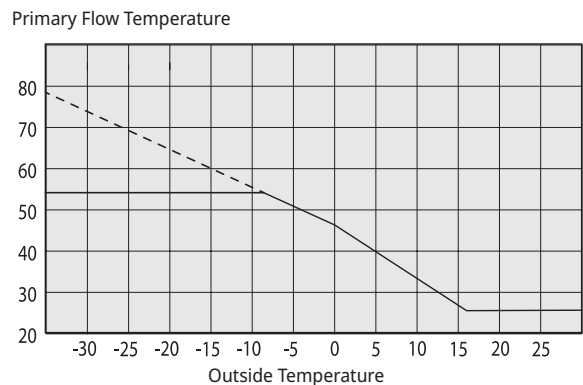

i If the values set are too low, this may mean that the desired room temperature is not being reached. You then need to adjust the heating curve, as necessary, following the method shown above.

Summer season

All properties have internal heat gains (lamps, oven, body heat, etc.), which means that the heating can be switched off when the outdoor temperature is lower than the desired room temperature. The better insulated the house is, the earlier the heating from the heat pump can be switched off.

The example shows the product set at the default value of 18°C.

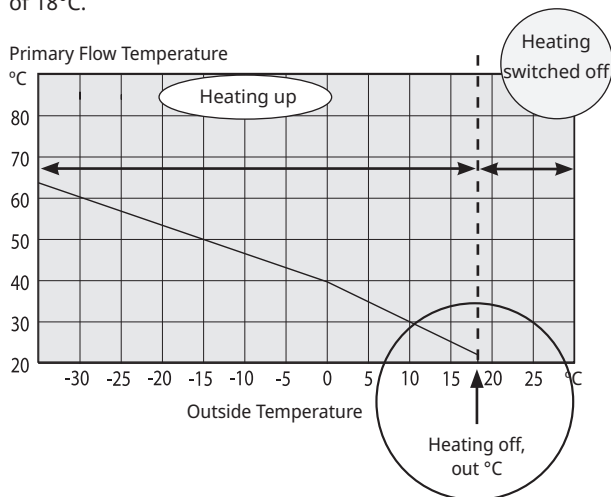

This value, "**Heating off, out °C**", can be changed in the "Advanced/Settings/Heat circuit" menu.

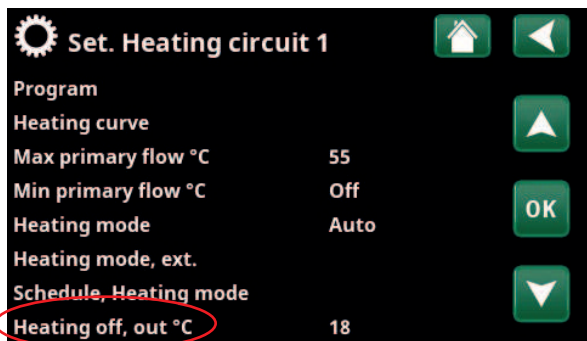

Part of the "Advanced/Settings/Heating Circuit/Heating Circuit 1" menu.

In systems with a radiator pump, the radiator pump stops when the heat is switched off. The heating starts up automatically when it is required again.

See chapter "Settings/Heating circuit" for information on setting the heating mode.

6. Technical data

General data		CTC EcoZenith i555 Pro 3x400V	CTC EcoZenith i555 Pro 1x230V	CTC EcoZenith i555 Pro 3x230V
Article number		589600001	589600002	589600003
Gross weight	kg	295		
Net weight	kg	260		
Dimensions (depth x width x height) (without packaging)	mm	1067 x 886 x 1700		
Required ceiling height	mm	1950		
Sound power L_{WA} (EN 12102)	dB(A)	15		
Kvs value mixing valve 17-28kW (option mixing valve 27-45kW)	m ³ /h	6.3 (10)		
Electrical data				
Rated electrical data		400V 3N~ 50Hz	230V 1N~ 50Hz	230V 3~ 50Hz
Rated power input (with option)	kW	18 (27)	9	14.10 (21.15)
Rated current (with option)	A	26.1 (39.1)	40	35.39 (53.09)
Max power immersion heater (at group fuse) (20A/ 25A/ 32A/ 35A/ 50A/ 63A)	kW	11.1/ 16.2/ 20.1/ 22.2/ 27.0/ 27.0	4.0/ 5.0/ 7.0/ 8.0/ 9.0/ 9.0	7.05/ 9.4/ 11.75/ 11.75/ 18.8/ 21.15
Group fuse	A	32 (50)	40	50 (63)
Ingress Protection class (IP)		IP X1	IP X1	IP X1
Power range, Immersion heater (min-max) upper / accessory lower	kW	0.3 - 9 0.3 - 9 3 - 9	3 - 9 - -	2.35 - 7.05 2.35 - 7.05 2.35 - 7.05
Warm side				
Water volume (V)	l	540		
Max operating pressure (PS)	bar	2.5		
Max operating temperature (TS)	°C	100		
Domestic hot water system				
Water volume (V)	l	11.4		
Max operating pressure	bar	9		

DHW performance according to prEN 16147		Normal	Comfort
Quantity of hot water (40°C)	l	263	600
Stand by heat loss S_{stby}	kW	0.590	
Material, DHW tank		Copper	

7. Measurements

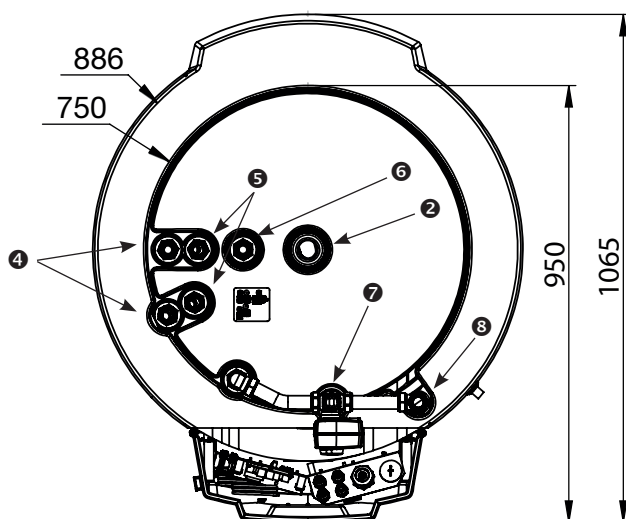
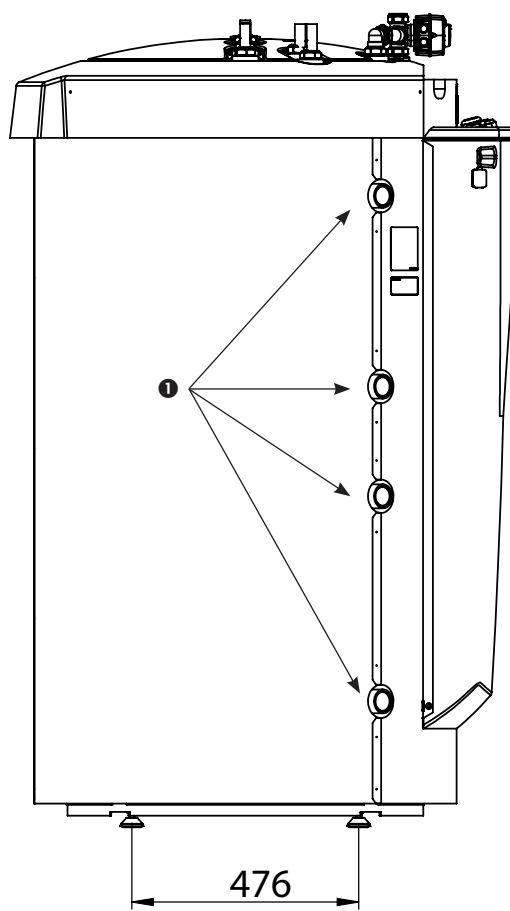
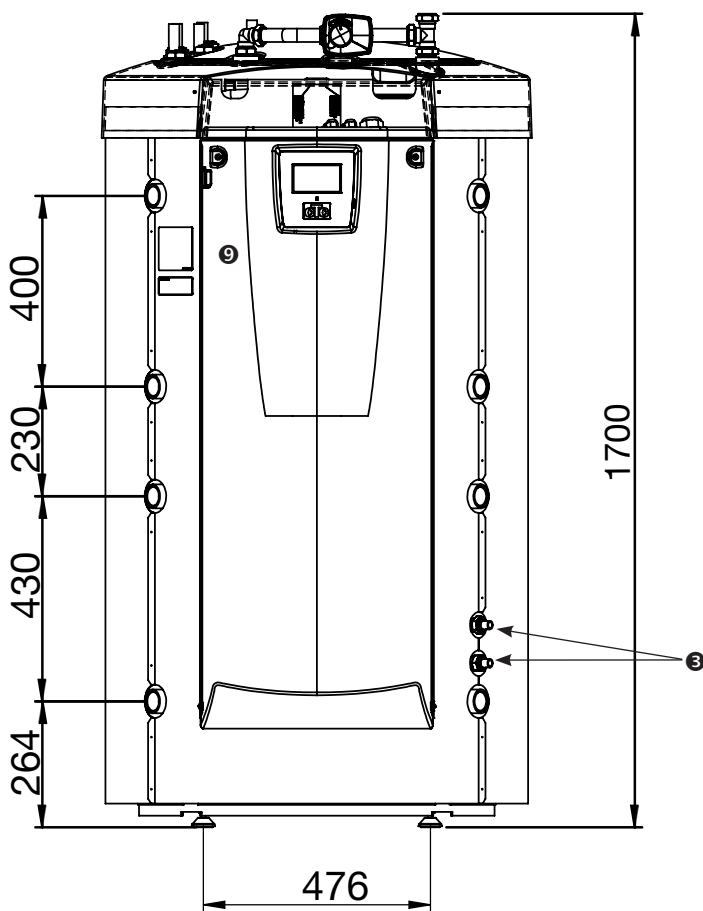

1. Heating connection, G 1 1/4" int.
2. Expansion vessel/Top con/Lifting socket, G 1 1/4" internal
3. Solar coil, Ø18 mm
4. Cold water Ø22 mm
5. Hot water Ø22 mm
6. DHW circulation, Ø22 mm
7. Radiator primary flow clamp ring 28 mm
8. Radiator return clamp ring 28 mm
9. Connection electric (behind the front)

8. Design

This chapter illustrates the main components and describes the subsystems which, in different configurations, form part of the main system. For more information about the CTC EcoZenith configurations, refer to the "Pipe connections" chapter.

8.1 Main components

Bivalent shunt valve

The automated mixing valve ensures that an even heat is continuously supplied to the heating circuit. The valve has double ports and takes the warm radiator water from the solar and heat pump heated water in the lower part of the tank first.

Control system

The CTC EcoZenith is equipped with an intelligent control system which controls and monitors all parts of the heating circuit. The CTC EcoZenith ensures that the most economical way of heating the house and the hot water is prioritised.

Finned Coil for DHW

The CTC EcoZenith is equipped with a well dimensioned finned copper coil and does not contain any heater which can rust. A low temperature can be maintained without the risk of legionella bacteria.

Immersion heater in upper tank

When connected to a heat pump, the immersion heater acts as additional heat.

(The top immersion heater is an optional extra).

Lower tank

In the lower tank, DHW is pre-heated in the coil by the solar- or heat pump-heated water.

Solar Coil Connections

The well dimensioned, 10 m long, finned coil can be connected directly to the solar collectors.

Immersion heater lower

Built-in lower immersion heater.

Fresh Water Connections

Here you connect the property's fresh water connections. The cold water is fed down to the lower part of the coiling, where it is preheated.

Top Connection

For connection of expansion vessel and/or safety valve.

Upper tank

In the upper part of the tank, the warm water in the coil is heated up to the desired temperature.

Upper Tank Connections

The upper tank, the additional part, can be heated by a heat pump and connected to heat sources such as electric, gas, oil and pellet boilers. Heat from a wood boiler is delivered to this part. Connections are placed symmetrically on both sides of the tank.

Heat Distribution Pipes

The heat distribution pipes ensure that heat from the solar coil is directed to the upper tank and that, after DHW is drawn off, cooled water is directed to the lower part of the tank to be heated again by solar energy or heat pump.

Insulated tank divider

Between the tank's upper and lower tank is an insulated tank divider. This provides high temperatures in the upper tank for good DHW capacity and low temperatures in the lower tank for best operating economy.

Lower Tank Connections

The heat pump and solar system are connected to the lower tank. Water to be heated by wood boiler is taken from here, and heat which is to be stored in a buffer tank is also taken from this part. Connections are placed symmetrically on both sides of the tank.

Insulation

The tank is insulated by 90 mm thick molded polyurethane foam for minimum heat loss.

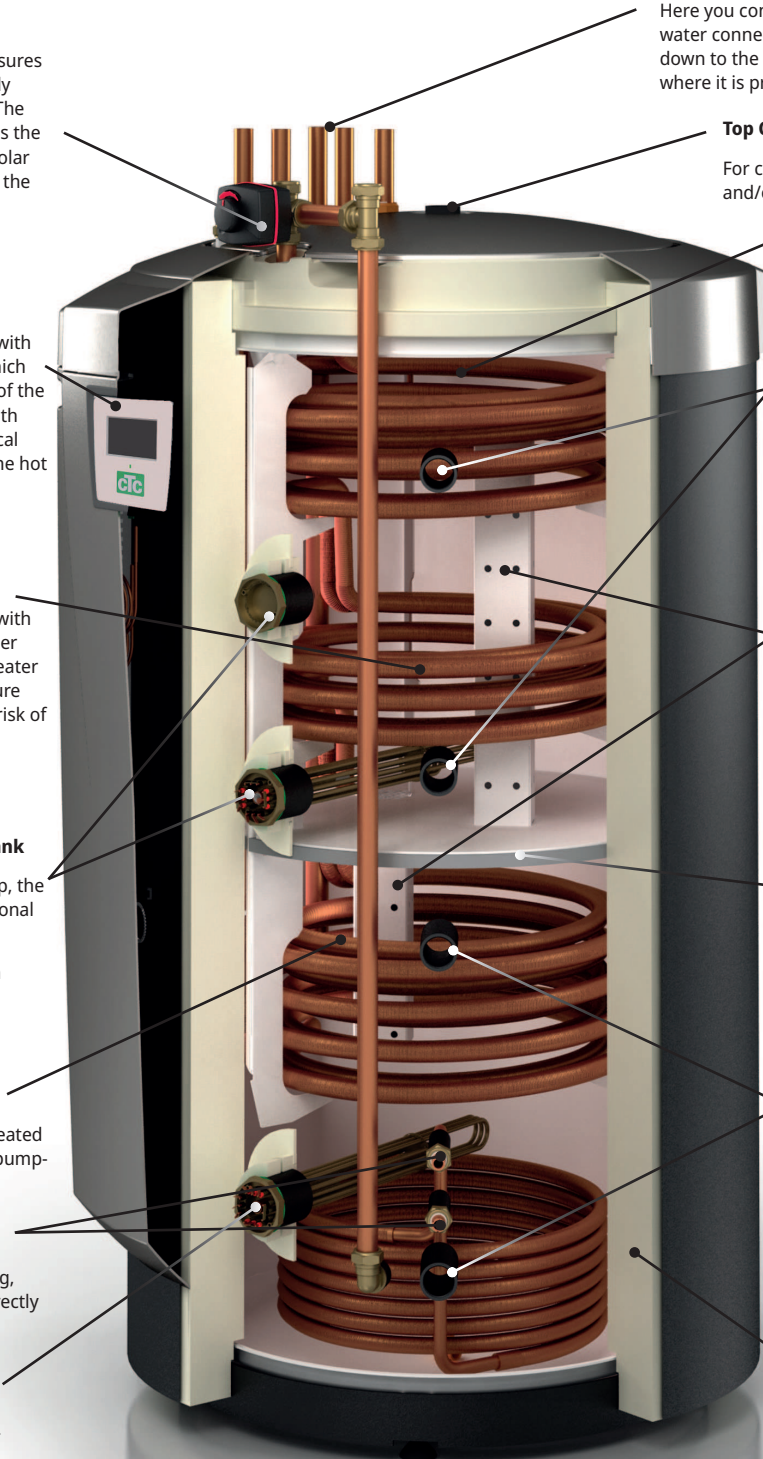

9. Function of CTC EcoZenith i555 Pro

CTC EcoZenith i555 Pro is a multi-tank with almost unlimited possibilities

The CTC EcoZenith is intended for houses and properties with water-borne heat. The multi-tank features include intelligent control, a water volume of 540 litres, bivalent mixing valve, two DHW coils, a solar coil and two 9 kW immersion heaters giving a total of 18 kW. You can easily add another immersion heater as an accessory to provide total power of 27 kW, controlled by the CTC EcoZenith.

The control is specially adapted to simultaneously control up to three of CTC's heat pumps, but it will also control and optimise the following:

- Pool
- Energy storage in buffer tanks
- Three heating circuits simultaneously
- Solar collectors and borehole recharging
- Cooling (passive cooling), floor or fan convector
- DHW circulation with time control
- Charging of extra DHW tank
- Connected wood boiler, gas/oil boiler and pellets

The CTC EcoZenith is well-insulated with 90 mm PUR and is well provided with connection options on both sides, ensuring clean and easy pipe installations. It also provides for extensions and additions to the system in the future.

The CTC EcoZenith i555 Pro is divided into two tanks which are isolated from each other in order to be able to hold different temperatures in the two tanks. This provides optimal function and operating economy.

The upper and the lower tanks are connected by heat distribution pipes which are especially developed for the solar energy to be able to form layers optimally in the entire volume of the tank and act as flow-through of the tank for wood operation, for instance (see picture).

Also refer to the "Immersion heaters" section in the "Detailed Menu Descriptions" chapter (Advanced/Settings/Immersion heaters).

Also refer to the "Lower tank" section in the "Detailed Menu Descriptions" chapter (Advanced/Settings/Lower Tank).

i Remember that menus which have not been defined cannot be seen.

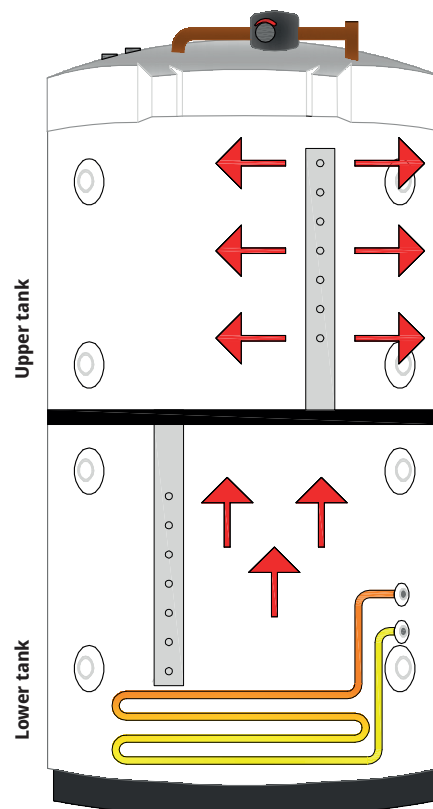

9.1 Heating Circuit

The CTC EcoZenith is equipped with a bivalent mixing valve, which always delivers an even temperature, without variation, to the heating circuit. The bivalent mixing valve is controlled by an outdoor sensor and, optionally, by a room sensor.

When operating with outdoor sensor alone, the desired curve inclination and adjustment are set. These values differ from home to home and should be adjusted to suit your needs.

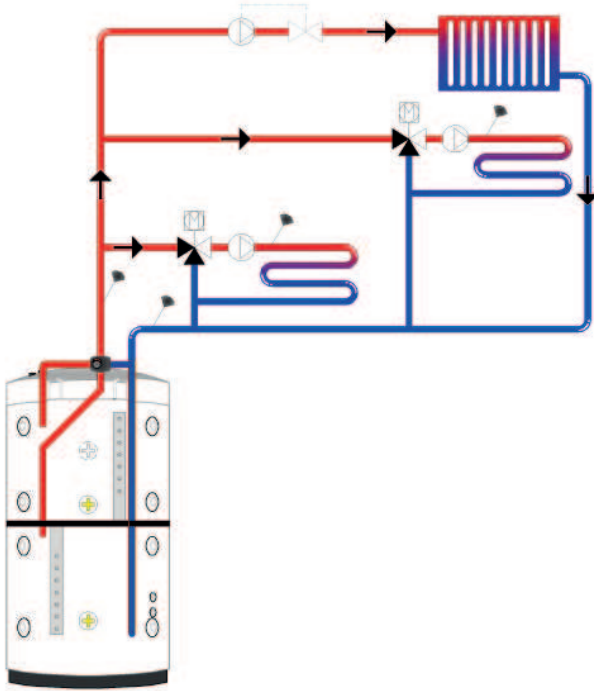

A room sensor that is correctly positioned provides more comfort and more heating circuit savings. The room sensor picks up the current indoor temperature and adjusts the heat, for example when it is windy outside and the house is losing heat, which the outdoor sensor is unable to register. During solar insolation, or other instances when heat builds inside the house, the room sensor can also reduce the heat, thus saving energy. Another way to save energy is to use the night reduction function, which reduces the indoor house temperature at certain times or periods, for example during the night or when you are away on holiday.

The CTC EcoZenith can control up to three heating circuits, each with its own room sensor. For instance, one radiator circuit plus two floor heating circuits. The bivalent mixing valve always attempts to use the energy from the lower tank first; this is especially important when a heat pump or solar collector is connected to the CTC EcoZenith. This ensures the system delivers good operating economy and that the upper tank stays warm to provide an abundance of DHW.

Also refer to the "Heating circuit" section in the "Detailed Menu Descriptions" chapter (Advanced/Settings/Heating Circuit).

Also refer to the "Room temperature" section in the "Detailed Menu Descriptions" chapter.

9.2 DHW

The final heating of the hot water takes place in the upper tank. It also acts as additional heating for the heating circuit when the lower tank is not enough.

The DHW is heated using two finned copper tube coils of approx. 40 metres connected in parallel. The coils preheat the water in the lower tank and the water reaches maximum temperature in the upper tank. The low inner volume and high rate of water turnover in the copper coil prevents build-up of bacteria.

With double coils, high draw-off flows can be obtained, as the heat conduction area is finned, on the inside as well as the outside. For more information on settings and tips, refer to the "DHW" chapter.

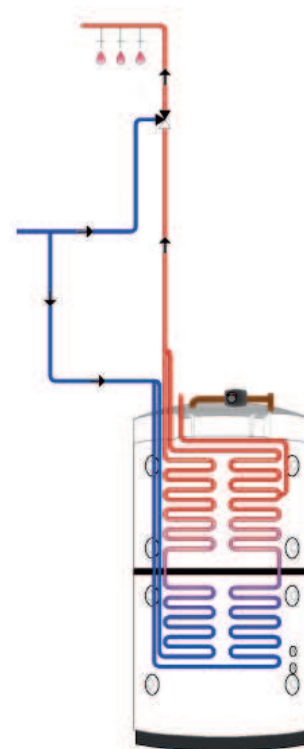

9.2.1 DHW circulation

The DHW coil has a connection for DHW charging, which can be used to heat an external cold water tank when greater tap capacity of DHW is required and allows connection of DHW circulation. This means that hot water is always available at the tap. To save energy the HWC pump can be time controlled from the CTC EcoZenith.

Also refer to the "Upper tank" section in the "Detailed Menu Descriptions" chapter (Advanced/Settings/Upper Tank).

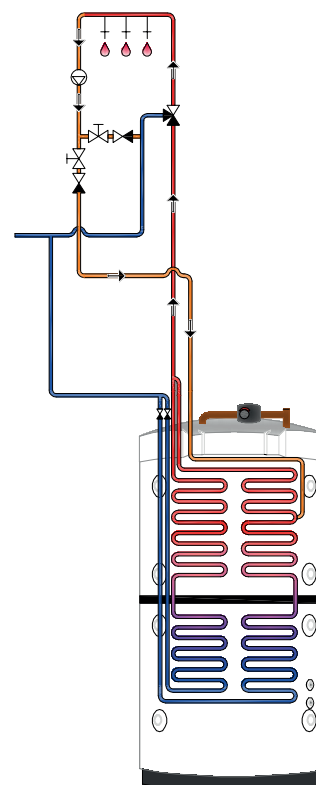

9.3 Heat pump

The CTC EcoZenith is designed with two parts in order to ensure the heat pump operates to maximum possible economy.

The heat pump is connected via two 3-way valves to the CTC EcoZenith and ensures that the heat is directed into the upper and lower tanks, respectively. For instance, when the heat pump pumps towards the upper tank, the 3-way valves send the flow to the two uppermost connections, so that the flow enters port 1 and exits through port 2.

The heat pump operates in two different ways, depending on whether it is the upper tank or the lower tank being charged.

9.3.1 Upper tank

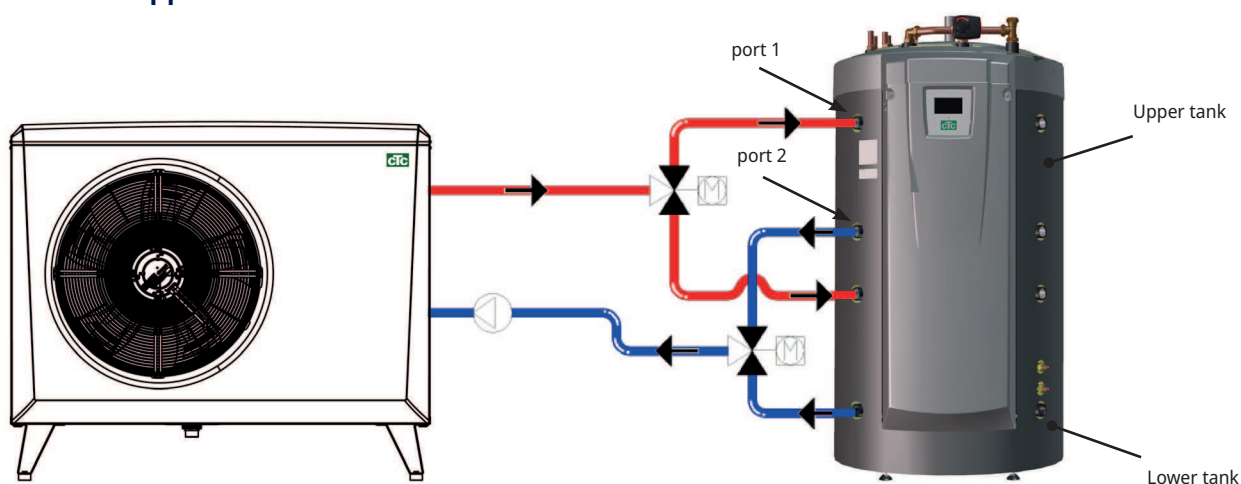

The final hot water heating takes place in the upper tank. This means that, with a high upper tank temperature, an ample DHW supply is obtained.

The upper tank has a factory-set stop temperature of 55°C, which means that the heat pump will work to achieve this temperature in the upper tank. When DHW is being drawn off and the temperature in the upper tank falls to 5°C below the stop temperature, the heat pump starts up and raises the temperature towards the set stop temperature.

The stop temperature can be adapted to DHW needs and to the heat pump model installed.

When there is also a need for heat in the house, the 3-way valves will automatically reverse direction and the heat pump continues to heat the lower tank as soon as the stop temperature 55°C in the upper tank has been reached. If the upper tank has not reached the stop temperature 55 °C within the factory-set charging period of 20 minutes, the 3-way valves reverse the direction and the heat pump charges the lower tank. This is to prevent loss of temperature in the heating circuit.

Also refer to the "Upper tank" section in the "Detailed Menu Descriptions" chapter (Advanced/Settings/Upper Tank).

Pressure/level switch

In some cases, extra protection is required due to local requirements or provisions. For example, the requirement in some areas is for the system to be installed within a water catchment area. The pressure/level switch connects to terminal blocks K22/K23/K24/K25 and is then defined in the "Advanced/Define/Def. Heat Pump" menu. If there is a leak, the compressor and brine pump stop and the "Flow/level switch" alarm appears on the display.

9.3.2 Lower tank

In the lower tank the heat pump operates to provide heat to the heating circuit.

Heat pump operation is of so-called floating condensation type. However, the lower tank never drops below the lowest set temperature.

Floating condensation operation is where the heat pump heats to the temperature required by the heating circuit. This temperature varies depending on the outdoor temperature and which set inclination and adjustment (the heat curve for the house) has been chosen. If a room sensor is installed, this will affect the temperature required in the system. During spring and autumn, when it is not so cold outside, a lower temperature is needed for the heating circuit, but during winter a higher temperature is needed to maintain the desired indoor temperature.

Savings from a heat pump are directly linked to the COP value. COP means the output divided by the supplied power. COP 4 therefore means, for instance, that the heat pump delivers 4 kW and uses 1 kW ($\frac{4}{1} = 4$).

The lower the temperature the heat pump needs to deliver, the higher the COP value obtained from the heat pump, as this will involve the compressor working to better advantage.

Therefore, the heat pump heats only to the temperature in the lower tank required by the heating circuit. This saves compressor life and maximises operating economy. The immersion heater, which is factory installed in the lower tank, is blocked as long as the heat pump is operating.

Also refer to the "Lower tank" section in the "Detailed Menu Descriptions" chapter (Advanced/Settings/Lower Tank) and the "DHW" chapter.

9.3.3 More Than One Heat Pump

If more than one heat pump is installed, heat pumps two and three are connected to the lower tank only.

Only one of the heat pumps alternates between DHW and heating operation.

9.3.4 Prioritisation of heat pump operation

When the product controls two or more heat pumps of different sizes, the connected heat pumps are divided into two categories: small or large heat pumps. Dividing the available heat pumps into two different size categories means it is possible to change the output in small steps and in this way achieve modulating operation.

When, for example, a need for power occurs, a large heat pump is switched on at the same time as a small heat pump is switched off, and vice versa when reducing power. Within both the small and large groups, reciprocal heat pump operation is prioritised according to accumulated operation time.

When combining different types of heat pumps, air/water and ground source pumps are prioritised according to the current outdoor temperature.

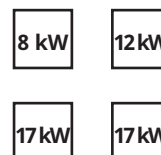

In the example above, 8 kW and 12 kW are classed as small, while the two 17 kW machines are classed as large.

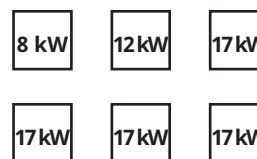

In the example above, 8 kW and 12 kW are classed as small, while the four 17 kW machines are classed as large.

9.3.5 Different Heat Pumps

CTC EcoZenith can control different types of heat pumps, CTC EcoAir (air source heat pump) and CTC EcoPart (ground source heat pump). The desired outdoor temperature at which the CTC EcoAir is prioritised over the CTC EcoPart is set in the "Advanced/Settings/Heat pumps 1, 2, 3" menu under "Prio CTC EcoAir/CTC EcoPart". This means that the operating economy can be maximised, as at a high outdoor temperature a greater energy yield is obtained from CTC EcoAir than from CTC EcoPart. This combination works exceptionally well for installations where, for example, the ground source heat pump is undersized. An air/water heat pump can then be used to give the borehole a longer time to recover and provide the system with increased power.

Remember that only one heat pump can be connected via the 3-way valves and charge DHW in the upper tank.

Also refer to the "Heat pump" section in the "Detailed Menu Descriptions" chapter (Advanced/Settings/Heat Pump).

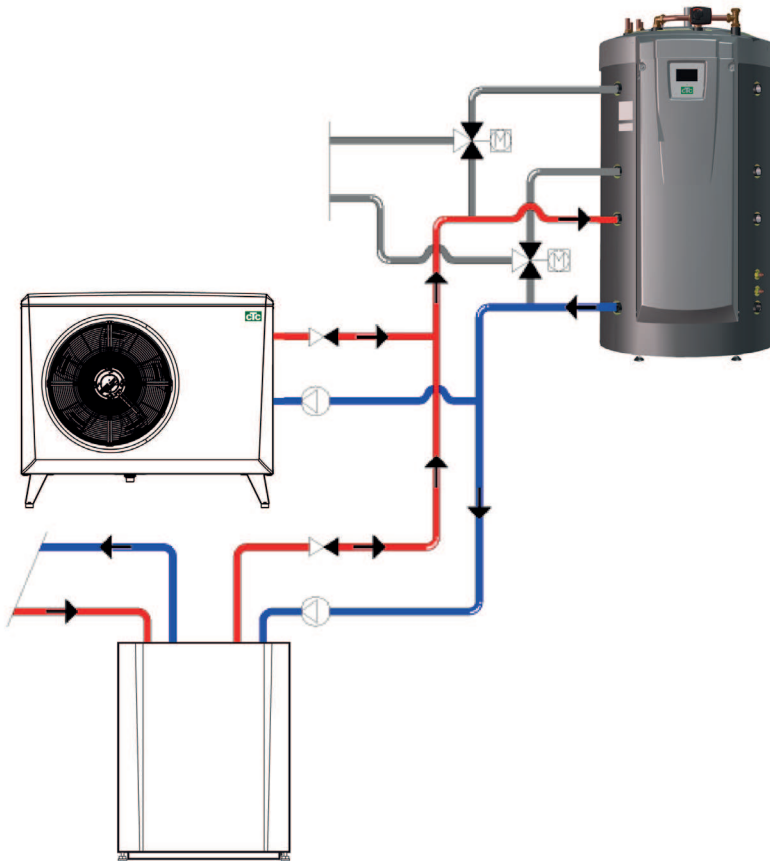

9.3.6 Speed-controlled charge pump (accessory from CTC)

Each heat pump should be provided with a separate charge pump that is controlled in tandem with its respective heat pump. If a speed-controlled PVM charge pump (accessory from CTC) is connected to the heat pump and controlled from the CTC EcoZenith, the flow will be automatically set without any adjustment needed via the control valve. In the upper tank the speed of the charge pump will be controlled so that the heat pump always delivers its highest possible temperature into the top of the CTC EcoZenith. This provides for quick access to DHW when the heat pump starts.

Towards the lower tank the speed-controlled charge pump will work for a fixed difference between flow and return from the heat pump.

If a speed-controlled charge pump is not installed, the flow must be adjusted manually, and the difference between incoming and outgoing water from the heat pump will vary, depending on the operation conditions during the year.

In cases where an air/water heat pump is installed and the outdoor temperature is lower than +2 °C, the charge pumps are started in order to protect against frost. If a speed-controlled charge pump is installed, the pump will only work at 25% of its maximum capacity. This provides for increased savings on the charge pump's operating economy, and the heat losses in the CTC EcoZenith are reduced compared to a conventional on/off charge pump.

Also refer to the "Heat pump" section in the "Detailed Menu Descriptions" chapter (Advanced/Settings/Heat Pumps 1-3).

9.4 Wood boiler

The CTC EcoZenith can be connected to a wood boiler, such as the CTC V40. The primary flow from the wood boiler is connected to the top of the CTC EcoZenith and the return flow to the wood boiler is connected to the lowest connection on the lower tank.

When firing is started and the flue gas sensor and/or boiler sensor reaches a set value (menu: "Advanced/Settings/Wood boiler" factory-set "100/70 °C"), the control goes into wood operation status when the temperature of the lower tank is above or equal to its reference value (setpoint). When the flue gas sensor is below the set value, wood operation status is interrupted.

It is recommended the wood boiler be provided with a charge system. A charge system such as Laddomat 21 is recommended for optimum performance. The charge pump in the charge system must be controlled from the wood boiler. In special cases, such as operation with a water jacketed stove, the charge pump may be controlled from the CTC EcoZenith without installing a charge system.

If the wood-fired system needs more water than the 540 litres contained in the product, the system needs to be supplemented with an accumulator tank.

Also refer to the "Wood boiler" section in the "Detailed Menu Descriptions" chapter (Advanced/Settings/Wood Boiler).



Schematic diagram only. The installer adds expansion vessels, safety valves, etc and sizes the system.

9.5 Additional boiler (pellets, oil, gas, electricity)

The CTC EcoZenith can control an external additional boiler (pellets, oil, gas, electricity). The additional boiler is connected to the upper tank. Use the menu to select whether the external additional boiler should have high or low priority. If high priority is selected, the external additional boiler is activated before the immersion heater(s); when low priority is selected, the immersion heater(s) is/are activated first.

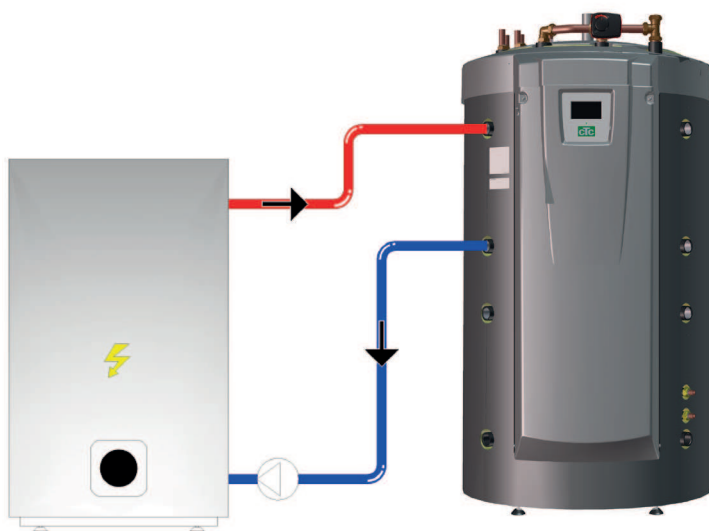

After a certain delay, which is factory set at 120 minutes, the unit with low priority is also started and helps the heat source with high priority.

If the immersion heaters are the lowest prioritised additional heat, the following must also be fulfilled in order for them to start: The temperature in the upper tank must be 4°C below the setpoint for the additional heat.

If the external boiler is the lowest prioritised additional heat, the following must also be fulfilled for it to start: The temperature in the upper tank must be 3°C below the setpoint for the additional heat and the immersion heaters must have moved along to the desired value (100% of set value) or to 6 kW in the first two hours after a power failure.

The CTC EcoZenith handles start and stop of the charge pump between the external boiler and the CTC EcoZenith.

The charge pump starts when there is a need for an external boiler.

If a temperature sensor is installed and an extra boiler is defined, the charge pump starts when an external boiler has reached the set temperature (factory set at 30°C).

The charge pump stops when there is no need for an external boiler. A stop delay of the charge pump can be set so that the charge pump runs even if the external boiler is off.

Also refer to the "External boiler" section in the "Detailed Menu Descriptions" chapter. (Advanced/Settings/Ext boiler).

Schematic diagram only. The installer adds expansion vessels, safety valves, etc and sizes the system.

9.6 Solar Energy

The CTC EcoZenith contains a 10 m long 18 mm finned and internally grooved solar coil which manages approx. 10 m² of solar collector. On larger solar collector installations, the solar energy is connected via an external heat exchanger (see figure 2). The heat exchanger is connected to the upper and lower connections on the lower part of CTC EcoZenith (either side is possible). If a greater number of panels is connected, one or more buffer tanks can also be installed in the system. More information on function and control of buffer tanks can be found in the "External Buffer tank" section.

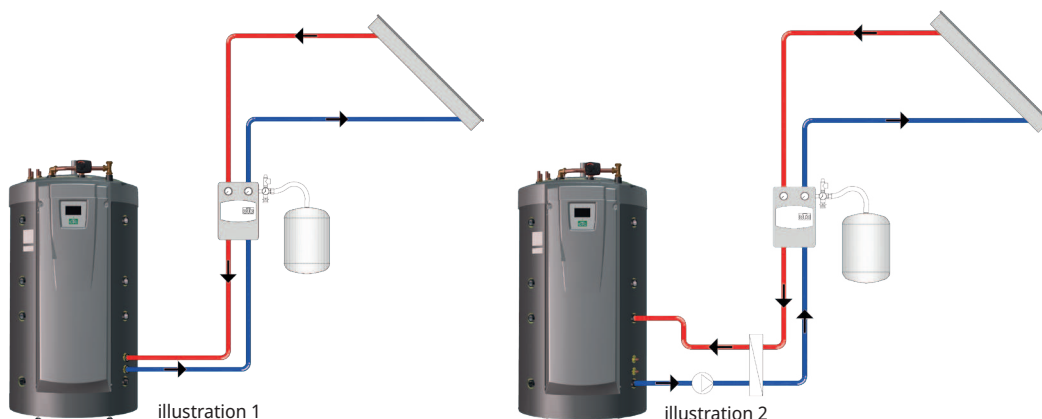

If the solar collectors produce a temperature which is more than 7 degrees (factory-set) higher than the sensor (B33), the charge pump starts and transfers the solar energy to the lower tank. The speed-controlled PWM pump controls the flow so that it always delivers a temperature which is 7°C higher. This means that if solar collector output rises, the charge pump will increase the flow, and if solar collector output decreases, the charge pump will reduce the flow. When the temperature in the lower tank increases or the solar collector loses temperature, and the difference between the temperature in the solar collector and the lower tank is below 3 degrees (adjustable), charging stops. Charging will not restart until the solar collector is again 7 degrees warmer than the lower tank.

When the temperature in the lower tank rises and becomes warmer than the upper tank, by the laws of physics, heat will rise into the heat distribution pipe and layer itself into the right temperature level in the upper tank through perforated holes in the distribution pipes. The colder temperature in the upper tank will, in the same way, sink down and distribute itself in its temperature zone in the lower tank through the distribution pipe which descends into the lower tank. Based on the factory setting, the sun will heat the lower tank in the CTC EcoZenith to 85 °C before the charging is stopped.

Also refer to the "Solar collectors" section in the "Detailed Menu Descriptions" chapter (Advanced/Settings/Solar collectors).

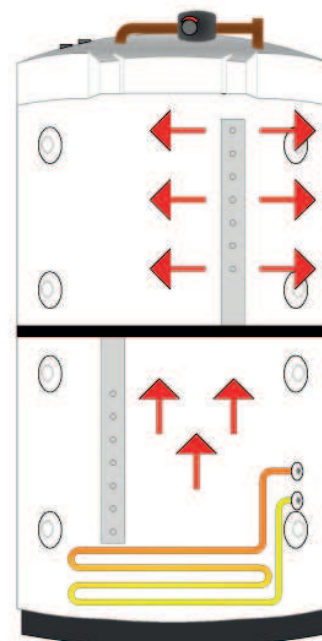

Schematic diagram only. The installer adds expansion vessels, safety valves, etc and sizes the system.

9.7 Recharging borehole/ground

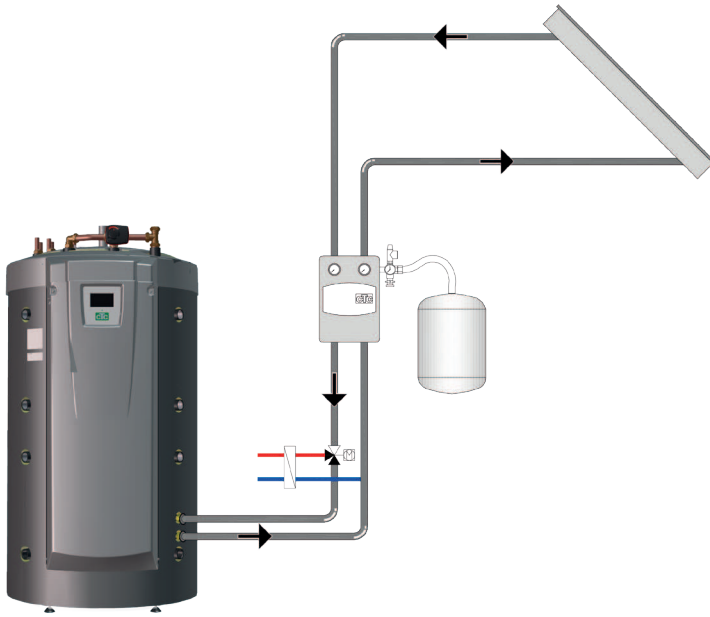

If a liquid/water heat pump is connected, a diverting valve can be installed on the solar circuit and connected to the brine circuit (borehole/ground loop). The solar collector temperature should be factory set at 60°C warmer than the brine temperature for charging to start. When the difference between the temperature in the solar collector and the brine circuit falls to 30°C, charging is stopped. If the brine circuit becomes warmer than the factory-set value of 18°C, recharging will also be interrupted, as the temperature then becomes too high for the heat pump to work.

Safety measures for the collector/solar system are available.

Also refer to the "Protection collector" section in the "Detailed Menu Descriptions" chapter (Advanced/Settings/Solar collectors/Protection Collector).

Also refer to the "Winter mode" section in the "Detailed Menu Descriptions" chapter (Advanced/Settings/Solar collectors/Winter Mode).

Schematic diagram only. The installer adds expansion vessels, safety valves, etc and sizes the system.

9.8 External DHW tank

An external DHW heater can be connected to the CTC EcoZenith. This results in a greater stored DHW volume, which contributes to higher DHW capacity.

The incoming cold water first passes through the CTC EcoZenith where it is heated before it flows into the DHW tank and out to the property's taps. This means that, when the temperature from the CTC EcoZenith is no longer sufficient, the entire volume of the DHW tank is still there to be used.

When the temperature in the upper tank of the CTC EcoZenith is factory set 5 °C warmer than in the external DHW tank, the charge pump starts. The heat from the upper tank charges the DHW tank until the increase in temperature in the latter does not exceed one degree per three minutes.

When DHW is stored below 60 °C, heating of the DHW tank at regular intervals is necessary to eliminate the risk of Legionella. This function is built into the CTC EcoZenith. First the upper tank is heated as far as possible using the heat pump. For the DHW heater to reach 65°C during 1 hour, the immersion heater is allowed to engage to raise the temperature over the final degrees. The factory setting for this is every fourteen days.

Also refer to the "Upper tank" section in the "Detailed Menu Descriptions" chapter (Advanced/Settings/Upper Tank).

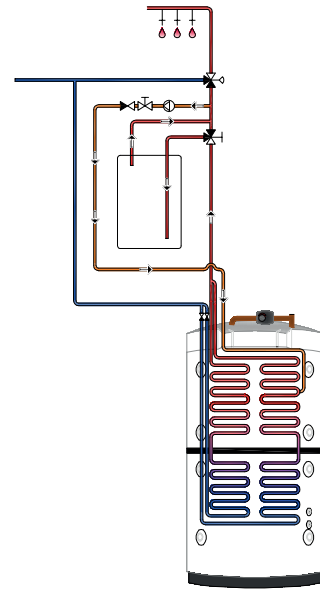

9.9 Pool

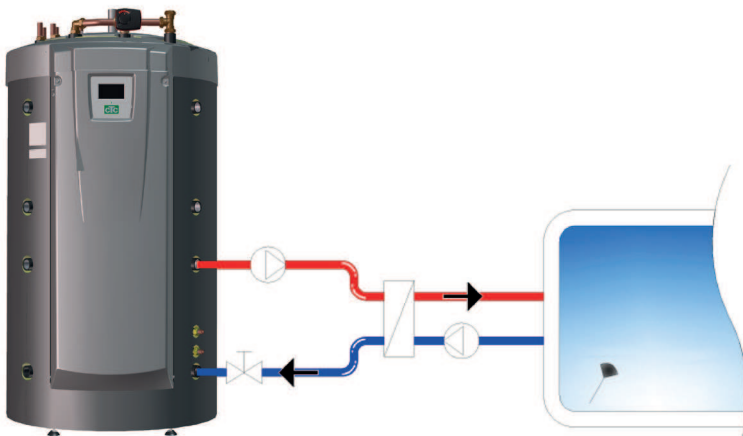

A pool is connected to the CTC EcoZenith's lower tank. Between the CTC EcoZenith and the pool, a heat exchanger is installed to separate the liquids.

A sensor in the pool starts and stops the pool's charge pumps in order to maintain the set temperature in the pool (factory set at 22°C). The temperature is allowed to fall by one degree before the charge pump starts again. It is also possible to set the pool priority to high or low, which determines whether additional heat can be used for heating the pool.

Also refer to the "Pool" section in the "Detailed Menu Descriptions" chapter (Advanced/Settings/Pool).

9.10 External buffer tank

The CTC EcoZenith can be connected to one or more buffer tanks. This is mainly used when connecting wood and solar energy systems where the volume in the CTC EcoZenith is not sufficient. Via the accessory "Charging External Buffer Tank", warm water can be sent both from the lower tank to the buffer tank(s) and from the buffer tank(s) back to the CTC EcoZenith. In other words, both charging and recharging of the energy are possible.

Also refer to the "HP charging" section in the "Advanced/Settings/External Buffer Tank" chapter.

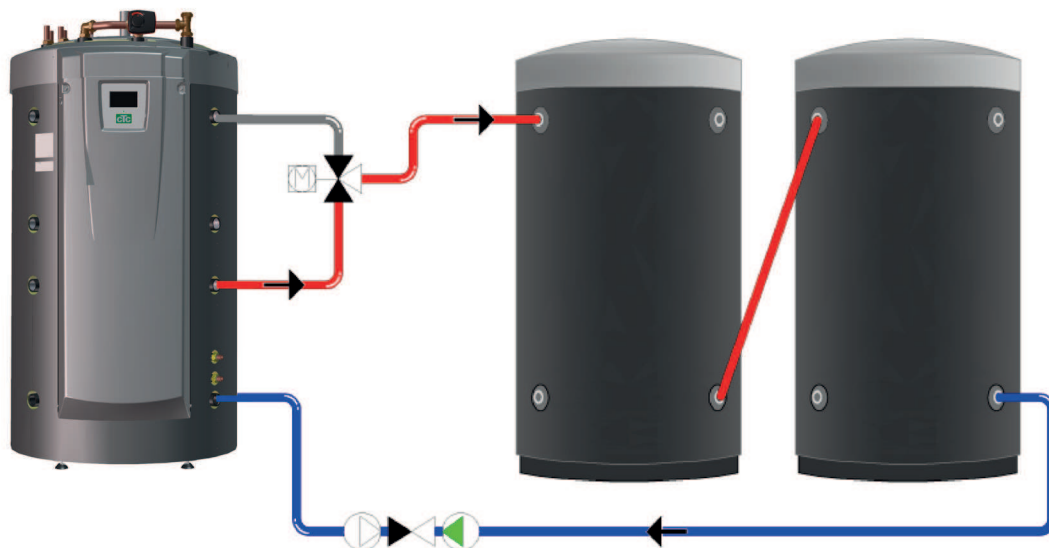

9.10.1 Solar Operation Control

When solar energy is activated, the transfer to the buffer tank(s) is performed in two ways depending on whether heating is needed for the heating circuit.

When heating is not needed for the heating circuit, the sun charges the CTC EcoZenith in order to achieve a high temperature and a large quantity of DHW. The solar collectors charge the CTC EcoZenith until the lower tank sensor reaches the factory-set 80 °C before the circulation pump starts up and transfers hot water from the CTC EcoZenith connection in the lower tank to the top of the first buffer tank. Charging continues until the sensor in the lower tank has fallen 3 degrees (transfer starts at 80 degrees and stops at 77 degrees). The lower tank must be at least 7 degrees warmer than the buffer tank for charging to be allowed to start. This applies independently of whether there is a need for heating or not.

When there is a need to heat the house, the transfer will be controlled by the reference value (setpoint) in the lower tank. When the sun has heated the lower tank to 7 degrees above the reference value, the transfer starts, provided that the lower tank is also 7 degrees warmer than the buffer tank. Efficiency of the solar collectors increases when they work towards a low water temperature, which is the case in spring and autumn, as there is no great need for heating during either of these seasons. The temperature levels stated above can be adjusted.

Schematic diagram only. The installer adds expansion vessels, safety valves, etc and sizes the system.

9.10.2 Wood operation control

The wood boiler charges the CTC EcoZenith until the sensor of the lower tank reaches the factory-set 80 °C before the charge pump starts up and transfers hot water from the lower tank into the top of the first buffer tank. Charging continues until the sensor in the lower tank has fallen 3 degrees (transfer starts at 80 degrees and stops at 77 degrees). The lower tank must be at least 7 degrees warmer than the buffer tank for charging to be allowed to start, based on the factory-set values.

9.10.3 Recharging from buffer tank to CTC EcoZenith

Recharging from buffer tank to the CTC EcoZenith is always performed to the upper tank, if possible. If charging to the CTC EcoZenith's upper tank is not possible due to too low a temperature difference, the controller checks if charging to the lower tank is possible. The condition for recharging is a 7 degree temperature difference.

Charging from the buffer tank to both the upper and the lower tanks in the CTC EcoZenith is stopped when the temperature difference has fallen to a difference of 3 degrees. The temperature levels stated above can be adjusted.

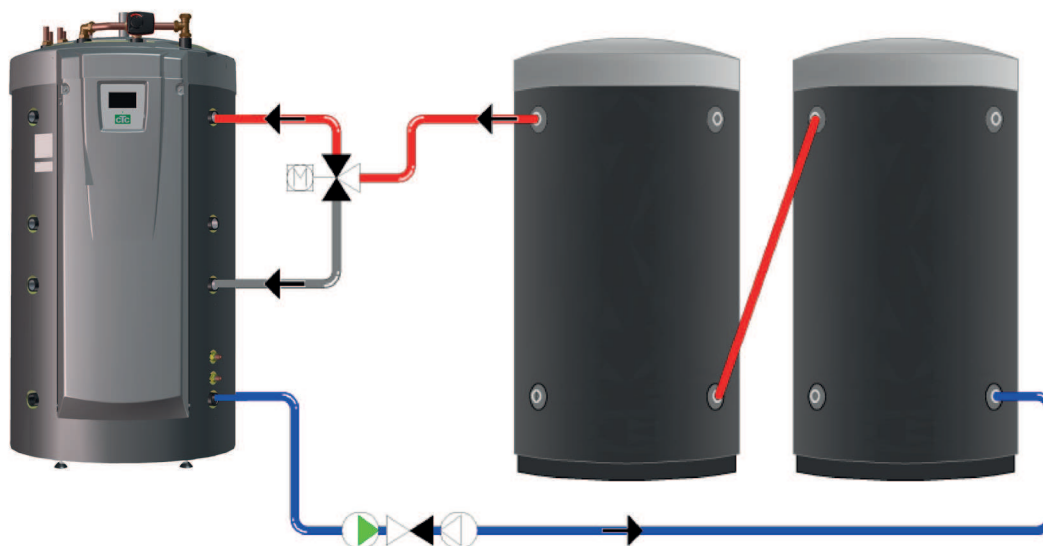

Schematic diagram only. The installer adds expansion vessels, safety valves, etc and sizes the system.

9.11 Cooling CTC EcoComfort

CTC EcoComfort is an accessory which utilises the cool temperatures of the borehole to create a cool indoor climate in summer. The extent to which you can cool a property depends on several factors, such as the rock temperature available for the case in point, the size of the house, the capacity of the fan convectors, the living area layout, etc.

NB: Remember to insulate pipes and connections against condensation.

Separate heating/heating circuit and cooling system (fan convector)

CTC EcoZenith i555 Pro simultaneously manages a heating circuit for heating and a separate system for cooling. This can be relevant if you want to cool a part of a property using e.g. a fan convector at the same time as need to heat another part.

Common heating/cooling

In order to be able to utilise cooling, you need to have an heating circuit to which cooling can be connected. If the heating circuit can be used for cooling the property, the heating circuit is used for heating in the winter and for cooling in the summer.

Desired room temperature

The desired room temperature is set on the CTC EcoZenith display. The water mix is automatically adjusted to achieve the right temperature for the amount of cooling needed (room sensor deviation). The greater the deviation, the colder the water fed into the system. Depending on the system in question, temperatures are not permitted to become too cold (as this can result in damage due to damp).

NB: For cooling it is recommended that the room temperature be set a few degrees higher than the set temperature for heating operation. Given that the room temperature tends to increase as the outdoor temperature increases, the cooling function will cut in.

Note too that cooling capacity depends, among other things, on borehole temperature, borehole length, flows and fan convector capacity, and will vary during the warm part of the year.

See CTC EcoComfort manual for more information.

9.11.1 Schematic diagram passive cooling - Common cooling/heating

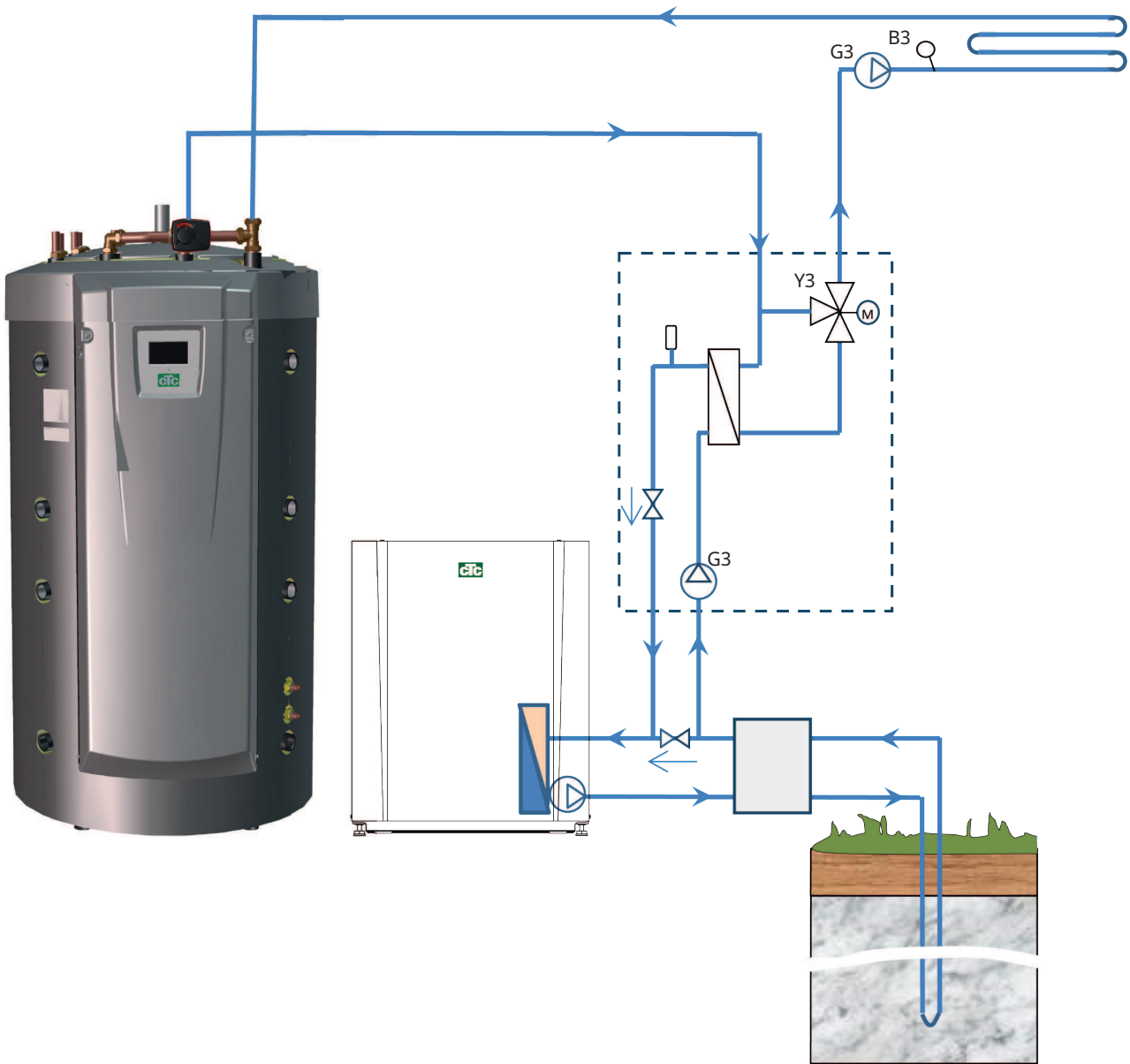

9.11.2 Schematic diagram passive cooling in separate heating systems

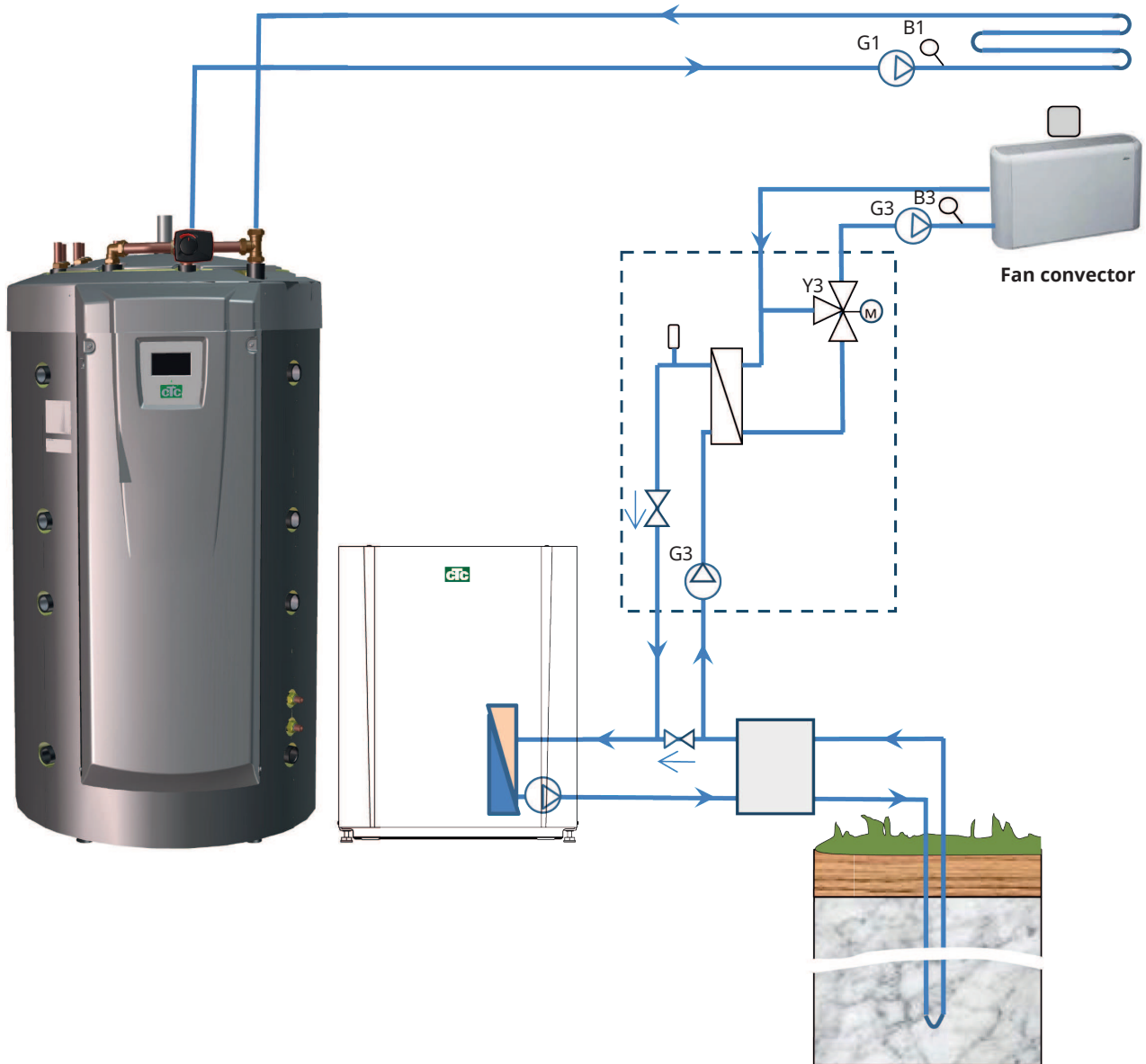

10. DHW

CTC EcoZenith i555 Pro has approx. 40 m of finned copper coils for the heating of DHW. These coils preheat the water in the lower tank and the water then runs through the upper tank for the final temperature increase. These two coils running parallel through the CTC EcoZenith allow high flows with low pressure differential, creating excellent conditions for good DHW capacity and comfort.

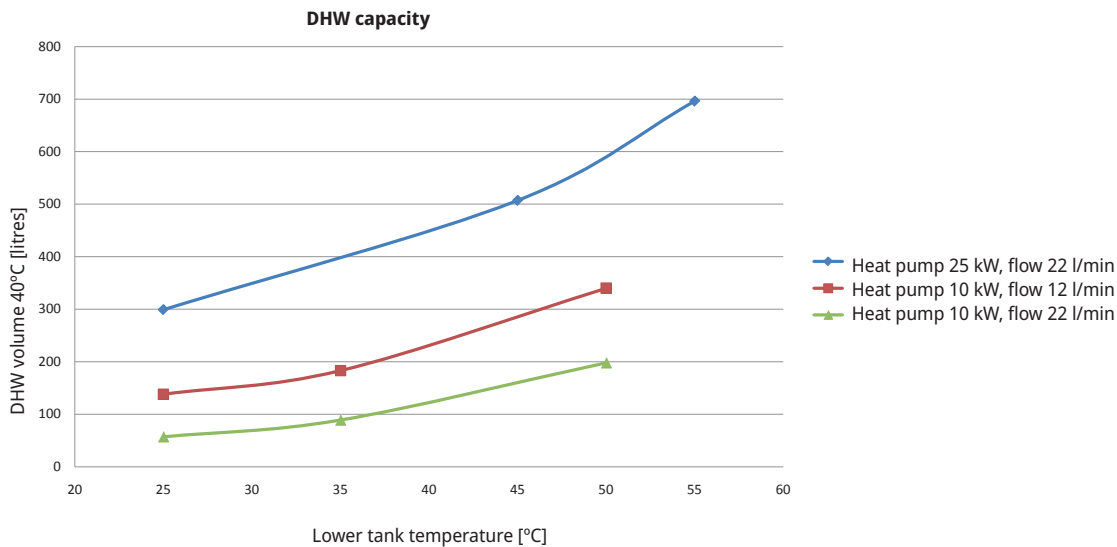

Operating Economy

Many people want to gain maximum benefit from the heat pump's low operating costs. The upper and lower tanks' temperature settings affect DHW temperature, capacity and operating economy. If the CTC EcoZenith is allowed to run on lower temperatures, this results in lower DHW capacity but greater savings.

A heat pump is more efficient (has a higher COP value) when it produces lower temperatures. For the sake of operating economy, this means that the lower tank of the CTC EcoZenith, which services the needs of the radiators, should have as low a temperature as possible. A floor heating circuit uses low temperatures, which benefits heat pump operation.

Solar energy operation also gives the best yield at lower temperatures. For example, on a cloudy day the solar panels do not heat up to the same extent, but still deliver their energy to the lower part of the tank, as the temperature in there is low.

The CTC EcoZenith is designed so that the temperature can be low in the lower tank where the preheating of the hot water takes place, and higher in the upper tank in order to further raise the temperature of the hot water. The need for DHW controls the temperature in the upper tank first. For best operating economy, start with a low temperature setting, for instance, the factory setting, and increase the temperature progressively if there is not enough hot water. Remember that setting the temperature higher than a temperature the heat pump can produce means that the immersion heater(s) will kick in and heat instead. This has an adverse effect on operating economy.

For higher DHW demands, it can be more economical to set a higher temperature in the lower tank instead of exceeding the temperature limit for the heat pump in the upper tank. However, this is less beneficial to heat pump operation for the radiator requirement because of the higher operating temperature. Furthermore, where solar panels have been installed, some of the solar energy will not be exchanged in the lower tank.

Extra DHW schedule

There is a possibility of increasing the product's DHW capacity at certain periods, with or without the help of the immersion heater(s). You can either select extra DHW immediately or schedule selection on a weekly basis. When the function is activated, the product starts producing extra DHW. The hot water is produced by the compressor working at maximum temperature, known as full condensation. In the "Installer/Settings/Upper tank" menu you can also select the immersion heater(s) to help to produce extra DHW. Remember that the function "extra DHW" means that more energy is consumed, especially if the immersion heater(s) is/are used. See also in the "Installer/Settings/Lower tank/Timer lower tank" menu.

Extra DHW Tank

Another way of improving the DHW capacity is to install an extra DHW tank. The CTC EcoZenith is prepared for controlling this, which provides the possibility of utilising heat pump energy to heat the extra DHW tank. This means that there is a large buffer tank with DHW, heated by the heat pump, while the benefits in terms of operating economy using low temperature in the lower tank are maintained.

Important to remember:

- Avoid running DHW at the highest flow capacity. If you run a bath at a rather slower rate instead, you will get a higher temperature.
- Remember that a poor mixing valve or a poor shower mixer can affect the DHW temperature.

11. Display settings

All settings are made directly on the display of the easy-to-use control unit. The large icons function as buttons on the touch screen.

Operational and temperature information is also shown here. You can easily access the different menus to find information on the operation or to set individual values.

Submenus that do not fit on the display can be accessed by pressing the down arrow on the display or by scrolling down manually. A white scroll bar shows where you are.

11.1 Start page

This menu is the system's start page. An overview of the current operational data is provided here. All other menus can be accessed from this menu. Depending on which system is defined, the following symbols appear in the start menu, for example:

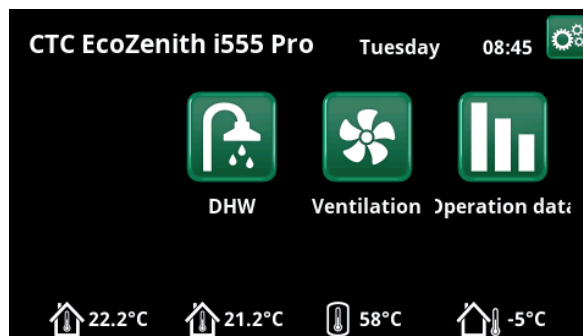

Main menu; the start page of the display.



Heating / Cooling

Settings for raising or lowering the temperature indoors and for scheduling temperature changes. Submenus for "Active Cooling" are shown if defined.



DHW

Settings for DHW production.



Ventilation

Settings for ventilation mode if the system includes a separate ventilation unit.



Operation data

This shows current and historical operational data for the system.



Advanced

This is where the installer configures the settings and service for your system.



Indoor temperature

Displays the current indoor temperature for each heating circuit if room sensors have been installed.



Tank temperature

Shows the current temperature in the DHW tank.



Outside Temperature

Shows the outdoor temperature.

11.2 Installation wizard

When starting up the system and during reinstallation (see chapter "Advanced/Service"), a number of system selections must be made. The menu screens that are displayed are described below; the values shown are only examples.

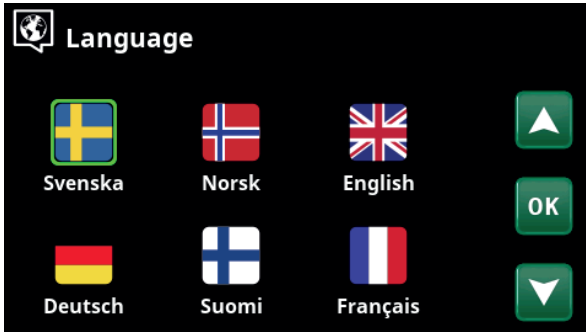

1. Choose language. Press OK to confirm.



2. Select the country where the heat pump is installed. Press OK to confirm.

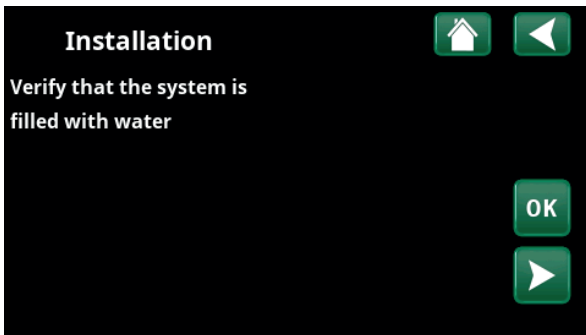

3. Verify that the system is filled with water. Confirm with "OK" and the "right" directional arrow.



4. Select the size of the main fuse using the "+" and "-" buttons. Confirm with the "right" directional arrow. For more information about settings, refer to the "Advanced/Settings/Immersion heater" chapter.



5. Use the (+/-) buttons to set the conversion factor for the current sensors. Confirm with the "right" directional arrow. For more information about settings, refer to the "Advanced/Settings/Additional heat" chapter.

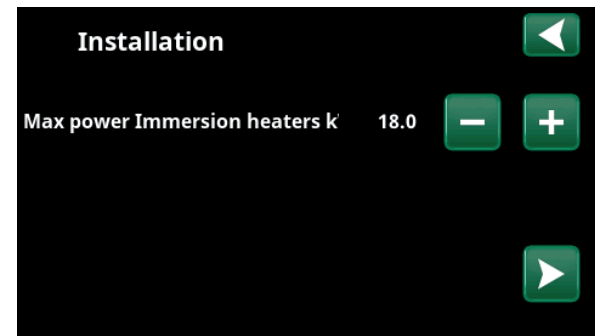

6. Select maximum immersion heater power using the "+" and "-" buttons. Confirm with the "right" directional arrow. For more information about settings, refer to the "Advanced/Settings/Immersion heater" chapter.



7. Specify whether Heat pump 1 is permitted or blocked. For "Permitted" press plus (+). For "Blocked" press minus (-). Confirm with the "right" directional arrow.

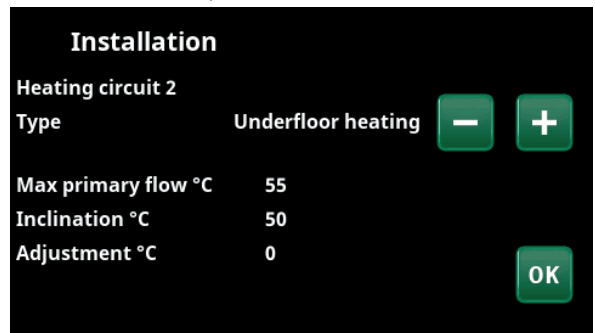

8. Specify whether heating circuit 1 applies to radiators or underfloor heating. Switch between "Radiator" and "Underfloor Heating" by clicking the (+) and (-) buttons. Confirm with the "right" directional arrow.

9. If Heating circuit 2 is defined, the corresponding menu for this system is displayed. Make a corresponding selection ("Radiator" and "Underfloor Heating") for Heating circuit 2 and finish the wizard with "OK".

11.3 Heating/Cooling



In the menu "HC- Heating/Cooling" the following settings can be made:

11.3.1 Setpoint setting with room sensor

Set the desired room temperature (set point) with the "minus" and "plus" symbols. In the example in the "HC1 Heating/Cooling" menu, the "Economy" programme and "Holiday mode" (V) are active for heating circuit 1.

In the "HC2 Heating/Cooling" menu, the "Cooling" mode is active.

"Holiday mode" and "Night reduction" only lower the room temperature when heating mode is active.

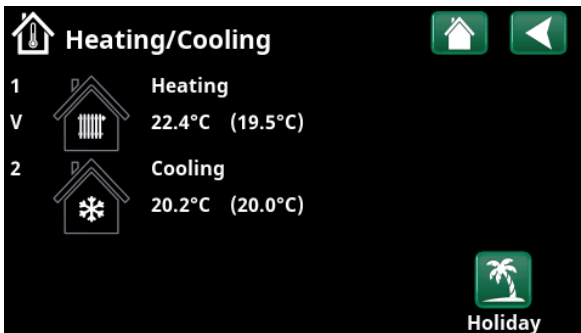

Click on heating circuit 1 or 2 to go to the menu of the respective heating circuit. In this menu you can activate "Holiday mode" for the heating circuits.

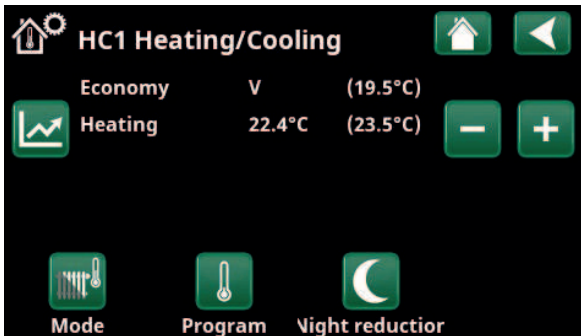

In the menu, programs "Economy" and "Holiday mode" (V) are active for heating circuit 1. In this example, both the "Economy" and "Holiday Mode" programmes are set to lower the set point (23.5 °C) by 2 °C, which means that the actual set point = 23.5 - 2 - 2 °C = 19.5 °C.

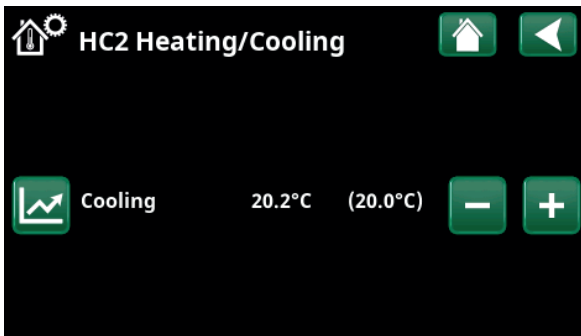

In the menu, "Cooling" (setpoint: 20.0 °C) is active for heating circuit 2. "Holiday mode" (V) does not lower the setpoint when cooling is active.

11.3.2 Program



Press the "Program" symbol and then the heating programme to be activated.

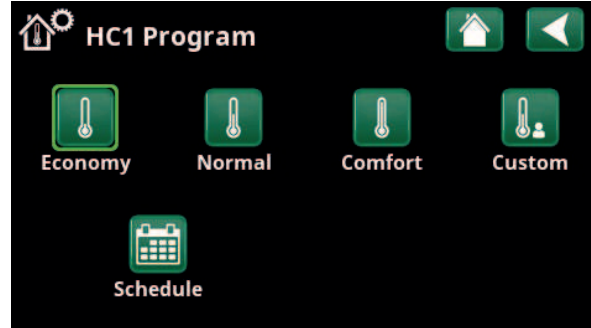

Menu "HC1 Heating/Cooling / HC1 Program" where program "Economy" has been activated.

Press and hold the symbol to go directly to the settings for the respective heating programs "Economy", "Comfort" and "Custom".

It is also possible to schedule the programs.

See chapter "Advanced/Settings/Heating circuit/Program" for information on how to set temperature increases/ decreases and delay times for the programs.

11.3.3 Heating curve



Press the heating curve symbol in the "HC1- Heating/Cooling" menu. The graph of the heating curve of the heating circuit is displayed.

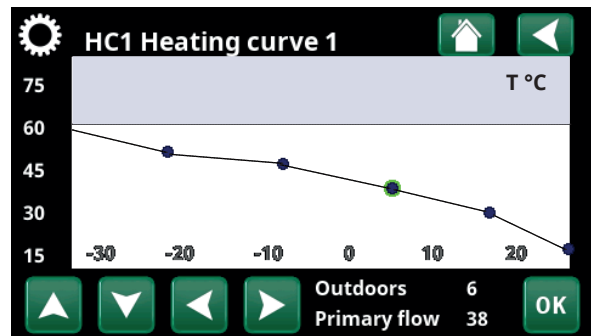

Menu "Heating/Cooling/HC1 Heating/Cooling".

The chapter "Advanced/Installation/Heating circuit" describes the setting of the heating curve.

See also chapter "House heating curve" for more information on adjusting the heating curve.

11.3.4 Heating mode



Press the "Mode" symbol and then select "Heating mode"; "Auto", "On" or "Off".

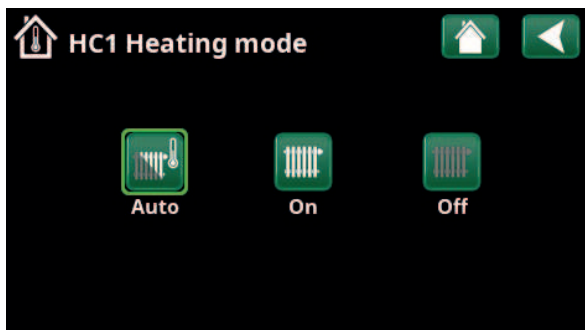

Menu "HC1 Heating/Cooling/HC1 Heating mode" where mode "Auto" has been activated.

Heating mode can also be selected in the menu "Advanced/Settings/Heating circuit/Heating mode".

See chapter "Advanced/Settings/Heating circuit" for more information.

11.3.5 Room temperature setting without room sensor

You can select "Room sensor - No" in the "Advanced/Define/Heating circuit" menu.

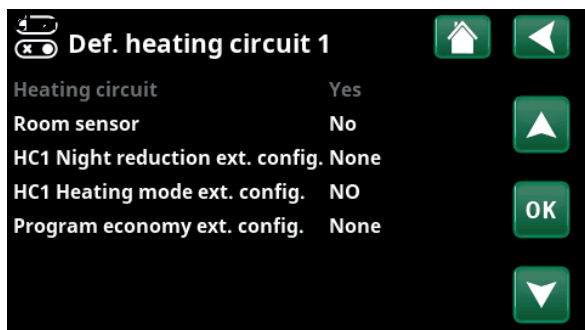

Menu "Advanced/Define/Heating circuit/Heating circuit 1".

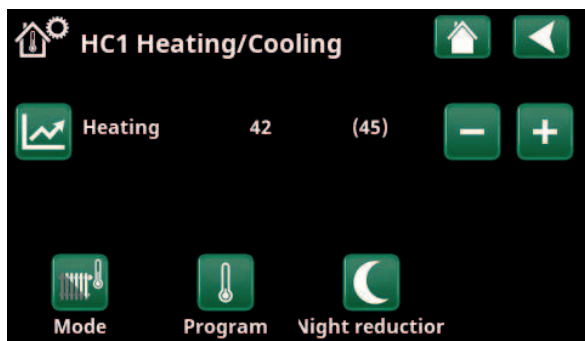

Menu "Advanced/Define/Heating circuit/Heating circuit 1". The heating circuit has no room sensors. The setpoint (primary flow temperature 45 °C) is shown in brackets, the current primary flow temperature 42 °C is shown to the left of the setpoint.

This is used if the room sensor is difficult to place, if the underfloor heating system control has its own room sensor or if you are using a wood-burning stove/fireplace. The alarm LED on the room sensor works as usual.

If a wood-burning stove or fireplace is used sporadically, the burning may cause the room sensor to reduce the temperature of the heating circuit and it may become cold in the rooms in other parts of the house. The room sensor can then be temporarily switched off during firing and the heat pump provides heat to the heating circuit according to the set heating curve. The radiator thermostats are throttled in the part of the house where the fire is burning.

If the room sensor has not been installed, the heating must be set according to the chapter "House heating setting".

11.3.6 Outdoor sensor/room sensor errors

If a fault occurs with an outdoor sensor, the product triggers an alarm and an outdoor temperature of -5 °C is simulated so that the house does not get cold.

If a fault occurs with a room sensor, the product triggers an alarm and automatically switches to operating according to the set curve.

11.3.7 Night Reduction Temperature



Night reduction means reducing the temperature indoors, via remote control or during scheduled periods.

In the menu "HC1 Night reduction" menu, the periods during the week for night temperature reduction can be scheduled.

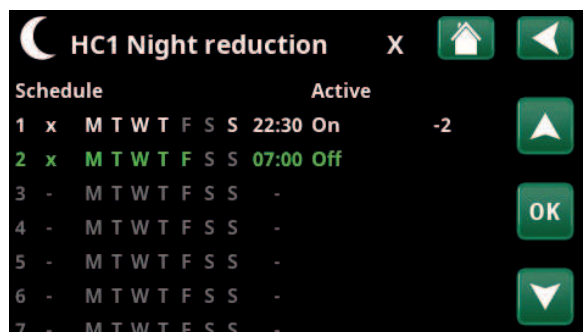

The schedule has been set for "Night Reduction" to be active weekdays between 22:30 and 07:00, except during the night between Friday and Saturday and the night between Saturday and Sunday (when no night reduction occurs).

The "Night reduction" icon in the "Heating/Cooling" menu only appears if a "Schedule" has been defined for the heating circuit in the "Advanced/Define/Remote control" menu.

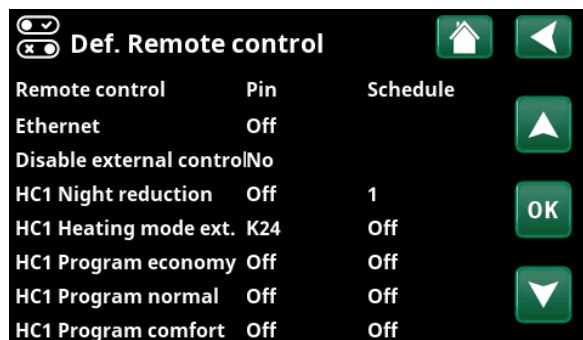

Menu: "Advanced / Define / Remote Control". The "HC1 Night Reduction" function is assigned to Schedule #1.

The "Schedule" chapter describes how to set schedules.

The value by which the temperature is reduced during remote control of the night reduction is set in one of the following menus.

Room sensor installed:

"Advanced/Settings/Heating circuit/Room temp reduced night red °C".

Room sensor not installed:

"Advanced/Settings/Heating circuit/Prim. flow reduced night red °C".

11.3.8 Holiday



Here you set the number of days you want the set temperature to be lowered, for example if you go on holiday.

The holiday period can be set in number of days or you can schedule the holiday with start/end date and time.

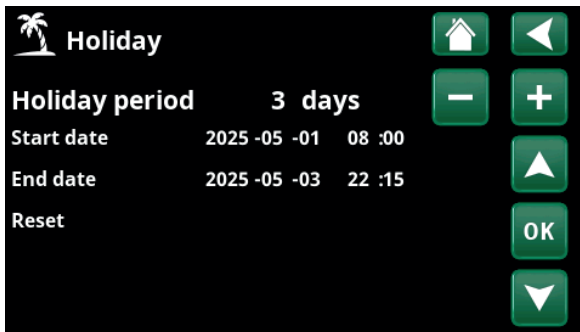

Menu "Heating/Cooling / Holiday".

Holiday period 0...300 days

Click on the "+" sign to set the number of days. The period is activated directly with date and time.

Start/End date

Set the date and time using the arrows.

NOTE! The number of days is displayed as 0.

Reset

Resets the holiday period to zero.

The number of degrees by which the temperature is lowered during the period is set in one of the menus:

Room sensor installed:

"Advanced/Settings/Heating circuit/Room temp reduced holiday °C".

Room sensor not installed:

"Advanced/Settings/Heating circuit/Prim. flow reduced holiday °C".

● When both "Night Reduction" and "Holiday Reduction" are in use, "Holiday Reduction" supersedes "Night Reduction".

● When holiday is enabled, hot water production is stopped. The "Temporary extra DHW" feature is also stopped.



11.4 DHW

This menu is used to set the hot water comfort level and "Extra DHW".

Extra DHW

The "Extra DHW" function can be activated here. When the function is activated (by setting the number of hours using the plus sign in the "Hot Water" menu), the heat pump immediately starts to produce extra DHW. It is also possible to remotely control or schedule hot water production according to specified times.

DHW mode

You set the values for this option which apply to the heat pump's normal operation. There are three modes:



Economy

For low hot water needs.
(Factory value stop temperature DHW tank: 50 °C).



Normal

Normal hot water needs.
(Factory value stop temperature DHW tank: 55 °C).



Comfort

For high hot water needs.
(Factory value stop temperature DHW tank: 58 °C).

Press and hold the button to go directly to the settings for the respective hot water programs "Economy", "Comfort" and "Custom".

The temperature can also be changed in the "Advanced/Settings/Upper tank/DHW Program/Stop temp HP" menu. If this is done, the green frame around the icon for this menu disappears.

11.4.1 Extra DHW

You can use this menu to schedule periods during weekdays when you want extra DHW. This schedule is repeated every week.

The stop temperature for Extra DHW is 60 °C (factory setting).

The "Schedule" chapter describes how to set schedules.

Click the "Extra DHW" heading to obtain a graphical overview of when the schedule is active during weekdays.



11.5 Ventilation

Refer to the "Installation and Maintenance Manual" for the CTC EcoVent ventilation product.

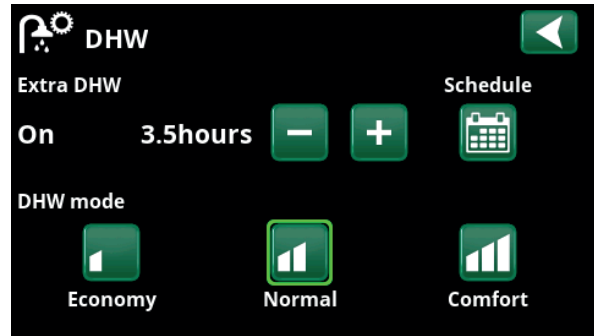

The "Extra DHW" function is set to be active for 3.5 hours.

NB: Set the time approx. 1 hour earlier than when you need the hot water as it may take some time to heat-up.

Tip: Set to "Economy" mode from the start. If the hot water is deemed insufficient, raise to "Normal" mode, and so on.

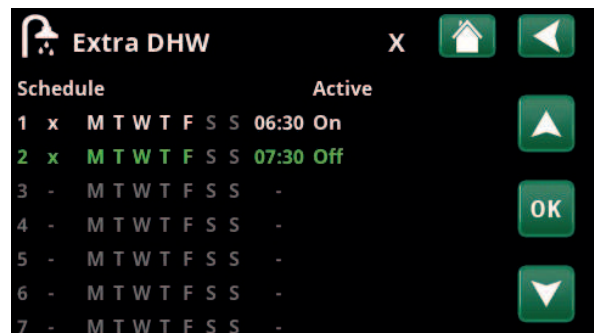

The "Extra DHW" function is set to be active on weekdays between 06:30 and 07:30.

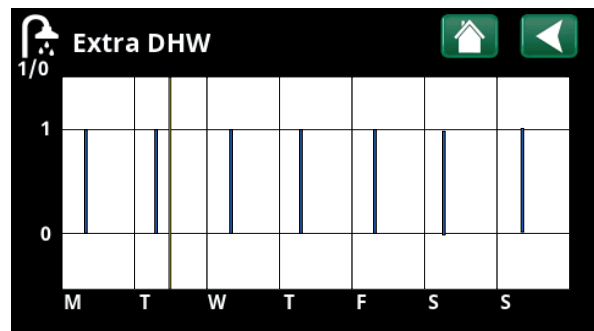

Use the Back button to switch between settings and preview. A vertical blue bar indicates when "Extra DHW" is active. A horizontal yellow line indicates the current time. The X axis represents the days, Monday to Sunday.

11.6 Schedule

In a Schedule, the periods can be set for when a function should be active or inactive during the weekdays.

The system does not allow certain functions to be active at the same time on the same schedule; for example, the "Night Reduction" and "Extra DHW" functions, but most functions can share the same schedule.

If several functions share the same schedule, changes to the schedule for one function will cause the same changes for the other functions that share the schedule.

To the right of the schedule header, an "X" will appear if the same schedule is also shared by another remote control function.

Click on the schedule's header row to see a graphical overview of when the schedule is active during the days of the week.

11.6.1 Defining a schedule

In this example, a night temperature reduction of heating circuit 1 (HC1) is programmed.

First, a schedule must be defined in the "Advanced/Define/Remote control" menu.

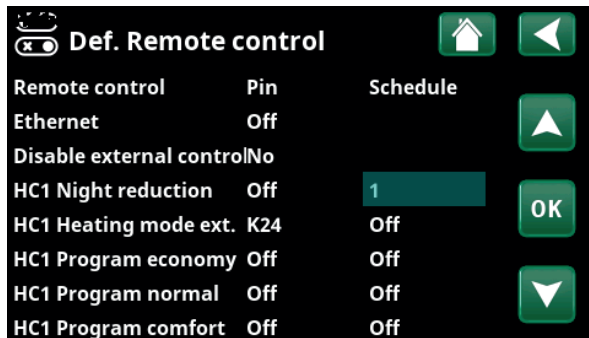

Menu "Advanced/Define/Remote Control".
The "HC1 Night Reduction" function is assigned to Schedule #1.

Enter a schedule (1-20) in the "Schedule" column in the "HC1 Night Reduction" row using the arrow keys, or click where the cursor is in the example.

11.6.2 Schedule settings

A schedule can be set for most remotely controlled functions in the menus under "Advanced/Settings".

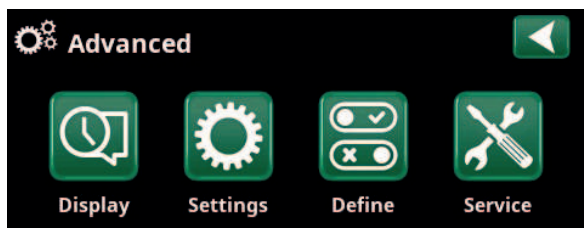

Menu "Advanced".

The schedules for "Extra DHW" and "Ventilation" can be accessed from the start page.

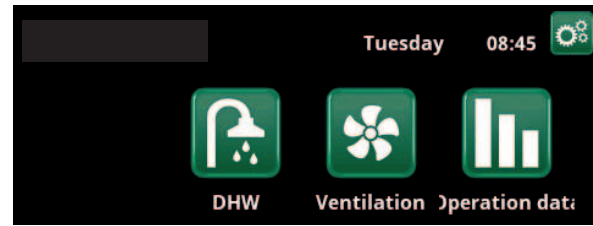

Main menu; the start page of the display.

The schedules for "Night reduction" and "Holiday" can be accessed via the "Heating/Cooling" menu on the start page.

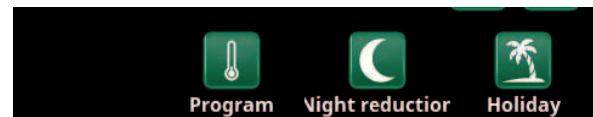

Click on the "Night Reduction" icon in the heating circuit "Heating/Cooling" menu to set the schedule.

The schedule includes 30 rows and a setting can be made in each row. For example, in one row you can set the date and time for the function to activate, and the time the function should deactivate in the row below.

In the example, "Night reduction" for heating circuit 1 has been set to be "On" from 22:30 to 07:00 on weekdays, except for weekends (Friday and Saturday nights).

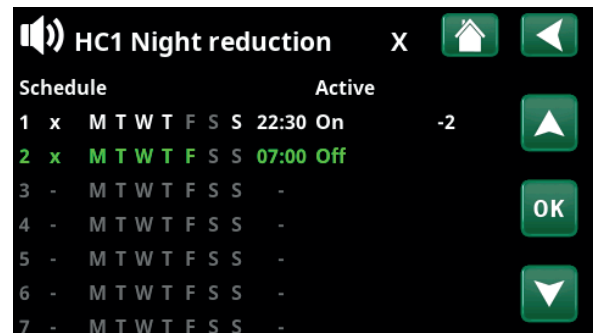

The schedule has been set for "Night Reduction" to be active weekdays between 22:30 and 07:00, except during the night between Friday and Saturday and the night between Saturday and Sunday (when no night reduction occurs).

The second row is highlighted green, which means that row is active at the current time.

Schedule (Active/Inactive/Restore factory settings)

Activate the schedule by setting it to "Active" mode. It is also possible to restore factory settings.

11.6.3 Editing a schedule

Go down to the first row and press "OK" to enable editing mode.

Time

Use the arrow keys to change the time (hours and minutes, respectively).

Day by day

Use the arrow keys (up arrow /down arrow) to mark active days in bold.

Action Off (On/Off)

This normally indicates whether the row will switch the function "On" or "Off".

However, for the "Night Reduction" and "SmartGrid Schedule" functions, the following applies:

- In the schedule for "Night Reduction", the temperature reduction that will apply during the period is specified in °C here instead. When a temperature is specified (setting range -1 to -30 °C), the status of the row automatically switches to "On".

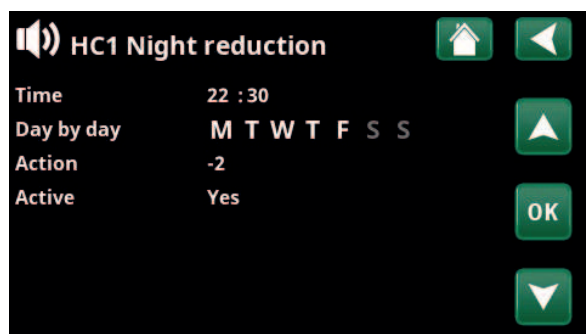

Setting the Night Reduction (-2 °C), weekday nights.

- When setting a "SmartGrid schedule", the SmartGrid function (SG Block., SG Low price and SG Overcapacity) is specified in the "Action" row. The status of the row automatically switches to "On".



The SmartGrid function "SG Low Price" is scheduled for weekdays 22:30-06:00. Go to the menu by selecting "SmartGrid schedule" in the "Advanced/Settings" menu.

Active Yes (Yes/No)

"Yes" means that the row is activated.



11.7 Operation data

The operation values shown in the menu screenshots are only examples.

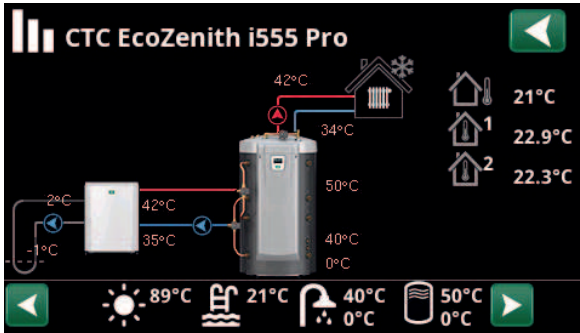

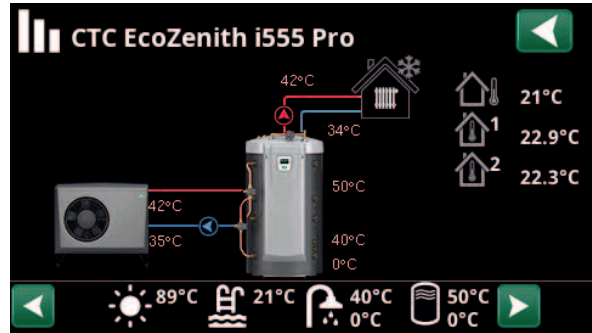

Main menu page for "Operation Data" with liquid-to-water heat pump CTC EcoPart connected. When the pumps are in operation, the pump icons also rotate on screen.





Main menu page for "Operation Data" with air-to-water heat pump CTC EcoAir connected. When the pumps are in operation, the pump icons also rotate on screen.

- 

Outside temperature Measured temperature, outdoor sensor.
- 

Indoor temperature Shows the room temperature for defined heating circuits (room sensors 1 and 2).
- 

Brine temperature Current temperature (2 °C) of the brine from the collector in the heat pump and return temperature (-1 °C) of the brine back into the collector hose.
- 

Heating circuit Current primary flow temperature (42 °C) to the house is shown on the left. Current return temperature (34 °C) is shown below.
- 









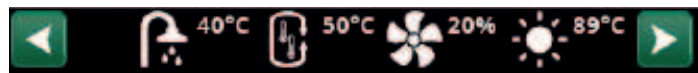



Heat pump, air-to-water The air-to-water heat pump is connected and defined for the circuit. The in and out temperatures of the heat pump are shown on the right.
- 

Heat pump, liquid-to-water The liquid-to-water heat pump is connected and defined for the circuit. The in and out temperatures of the heat pump are shown on the right.

The icon bar at the bottom of the menu page displays icons for additional functions or subsystems that have been defined.

Scroll using the arrows or swipe in the list if not all the icons fit on the page.



-  Ventilation
-  Pool
-  Solar panels
-  Wood boiler
-  DHW
-  History
-  External buffer
-  External Boiler
- 
- 
- 
- 

The gear icon is a shortcut to "Settings" for the respective part.



11.7.1 Operation data, Control unit

- Status** **DHW**
Shows the various operational statuses, refer to the table below:
- Delay mixing valve** **180**
Shows the mixing valve delay (in minutes) for production of heat from the upper tank to the heating circuit.
- Tank upper °C** **60 (60) (40)**
Temperature and setpoint (in brackets) in the upper tank. The value in the brackets is the temperature that the immersion heaters are working towards.
- Tank lower °C** **40 (43)**
Temperature and setpoint (in brackets) in the lower tank.
- Immersion heater, kW** **3.0 + 2.0**
The output of the upper and lower immersion heaters is shown here. The lower immersion heater is only allowed to operate when the heat pump is blocked for some reason.
- Current L1/L2/L3 A** **0.0 0.0 0.0**
Displays current in phases L1-L3 if current sensor installed. If not configured, only the highest value phase is displayed.
- Delay additional heat** **180**
The menu displays the required delay in minutes of subnormal temperature in the buffer tank before additional heat E1 is started.

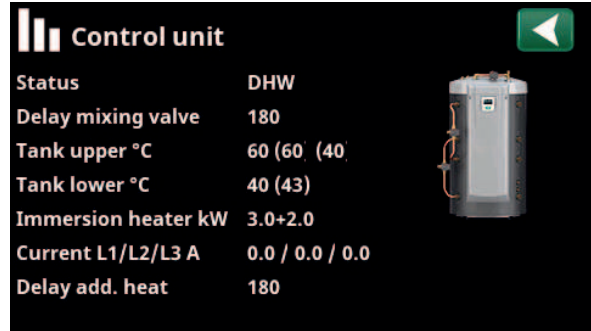

Menu Operation Data/Control Unit.

The first figure indicates the current operational value, and the value in brackets indicates the setpoint which the heat pump is trying to achieve.

Control unit status	
DHW	DHW is produced.
Heating	Heat is produced for the heating circuit (HC).
Wood	Only shown for System Type 1. Shown if the wood boiler is producing heat. Wood operation is activated when the flue gas temperature exceeds the set value and the temperature is equal to or above its reference value (setpoint). When wood operation is active, the heat pump or additional heat is not used for heating. Wood operation is also activated when the primary flow sensor (B1) is 10 °C above the setpoint.
Heating-Mixing	Heat is produced for the heating circuit (HC). Mixing valve Y1 works according to the setpoint of the primary flow sensor. If the boiler temperature is 10 °C higher than the primary flow setpoint, mixing valve Y1 will begin to adjust down to this temperature.
DHW + Heating	DHW and heat are produced for the heating circuit (HC).
Off	No heating takes place.



11.7.2 Operation data, Heating circuit 1-*

Click on a heating circuit to see more detailed operation data in a new menu window.

Mode **Custom**

Shows the active DHW program.

Status **Heating**

Shows the operational status of the heating circuit, see the table below.

Primary flow °C **42 (48)**

Shows the temperature supplied to the current heating circuit and the setpoint in brackets.

Return flow °C **34**

Shows the temperature of the water returning from the heating circuit to the heat pump.

Room temp. °C **21 (22) (25)**

Shows the room temperature for the heating circuit if room sensor installed. In brackets, the setpoint is shown for the "Heating" and "Cooling" status.

Radiator pump **Off**

Shows the operational status of the radiator pump ("On" or "Off").

Mixing valve **Open <50%**

Shows whether the mixing valve "opens" or "closes" the heating or cooling flow to the heating circuit and when the mixing valve is in position "<50%" or ">=50%".

Which mixing valve is meant depends on whether heat or cooling production is defined and how cooling has been defined.

Delay mixing valve **25**

Mixing valve delay (in minutes) for production of heat from the upper tank to the heating circuit.

SmartGrid **Off**

Shows the status of the SmartGrid functions for the selected heating circuit.

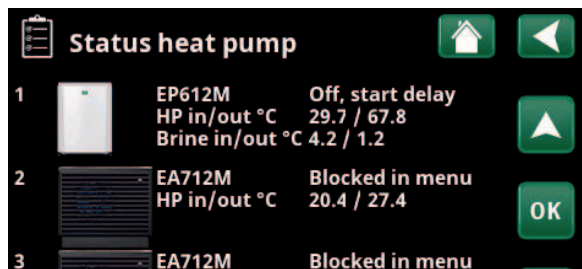

"Operation data, heating circuit" menu. The menu shows the current temperatures and status of defined heating circuits.

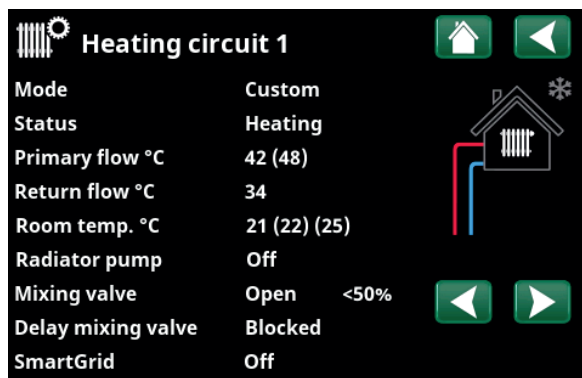

The menu shows detailed operation data for the selected heating circuit. Click the arrows or swipe in the menu to view defined heating circuits.

*CTC EcoZenith i555 can control up to 3 CTC heat pumps and 3 heating circuits simultaneously.

Heating circuit status	
Heating	Heating is produced for the heating circuit (HC).
Cooling	Cooling is produced for the heating circuit (HC).
Holiday	"Holiday reduction" of room temperature is active. For more information, refer to the "Heating/Cooling" chapter.
Night reduction	"Night reduction" of room temperature is active. For more information, refer to the "Heating/Cooling" chapter.
Off	No heating/cooling produced.

11.7.3 Heat pump status*

This menu appears when several heat pumps have been defined.

Status HP **Off, start delay**

Heat pump 1-3 can have the status according to the table below.

HP in/out °C **29.7 / 67.8**

Shows in/out temperatures from the heat pump.

Brine in/out °C **4.2 / 1.2**

Shown for liquid-to-water heat pumps.

Shows in/out temperatures of the brine.



Liquid-to-water heat pumps:

CTC EcoPart 400

CTC EcoPart 600M**



Air-to-water heat pumps:

CTC EcoAir 400

CTC EcoAir 500M/600M/700M**

** Modulating heat pumps

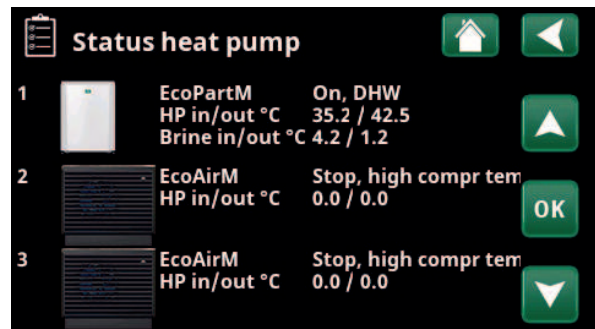

The menu shows the status and operating temperatures of defined heat pumps.

*CTC EcoZenith i555 can control up to 3 CTC heat pumps and 3 heating circuits simultaneously.

Status heat pump (example)	
Blocked in menu	The heat pump's compressor is "Blocked" in the "Advanced/Settings/Heat Pump/Heat pump 1" menu*.
Communication error HP	The control unit cannot communicate with the heat pump.
On, DHW	The heat pump heats the DHW tank.
Off, start delay	The heat pump's compressor is off and is prevented from starting due to the start delay.
Off, start ready	The heat pump's compressor is off but ready to start.
Flow on	Displayed if there is flow in the charging coil.
On, heating	The heat pump is producing heat for the heating circuit.
Defrost	The heat pump defrosts. Displayed for air-to-water heat pumps:
Stop, low outdoor temp	Outdoor temperature lower than min. limit - air-to-water heat pump only.
Stop, high outdoor temp	Outdoor temperature higher than max. limit - air-to-water heat pump only.
Blocked	The heat pump has stopped due to a temperature or pressure that has exceeded its maximum value.
Off, alarm	The compressor is off and gives an alarm signal.
Stop, tariff	The compressor is blocked due to the remote control function being active.



11.7.4 Operation data, Compressor HP

Status **On, heating**

Displays the heat pump status, see examples of status modes in the "Status, heat pump" menu.

Model* **EP412**

Shows the heat pump model.

Compressor **65RPS R**

Shows the compressor speed. "R" stands for "Reduced Mode" (for example, during "Silent Mode").

Charge pump **On 78%**

Shows operating status of the charge pump ("On" or "Off") and the flow in percent (0-100).

Brine pump **On 50%**

Shows operating status of the brine pump ("On" or "Off") and the speed in percent.

This menu bar is displayed for liquid-to-water heat pumps.

Brine in/out °C **4.0 / 1.0**

This shows the brine pump's incoming and outgoing temperatures.

This menu bar is displayed for liquid-to-water heat pumps.

Fan **On 80%**

Shows operating status of the fan ("On" or "Off") and the fan speed in percent.

This menu bar is displayed for air-to-water heat pumps.

Compressor heater **Off**

Displays the operating status of the compressor heater ("On" or "Off").

Applies only to CTC EcoAir 700M.

HP in/out °C **35.0 / 42.0**

Shows the heat pump's incoming and outgoing temperatures.

Flow l/min **0.0**

Shows flow to/from the heat pump.

Outdoor temp °C **3.5**

Shows the outdoor temperature on the sensor located on the heat pump.

This menu bar is displayed for air-to-water heat pumps.

Current A **9.8**

This menu bar is displayed depending on heat pump model.

AC Choke °C **75.0**

Shows the temperature of the heat pump AC choke.

This menu bar is displayed for liquid-to-water heat pump CTC EcoPart 600M/700M.

Compressor temp °C **0.0**

Shows the temperature in the compressor.

Software HP PCB **20230301**

Shows the heat pump software version.

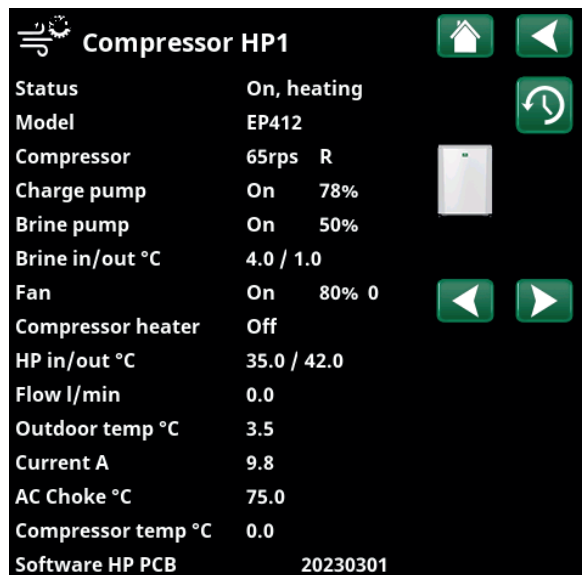

The menu shows detailed operation data of the selected heat pump. If the system includes several heat pumps, click the desired heat pump in the "Status heat pump" menu to access this menu.

*CTC EcoZenith i555 can control up to 3 CTC heat pumps and 3 heating circuits simultaneously.



11.7.5 Stored operation data

This menu shows accumulated operating values.

The operating values shown in the menu screens are only examples. The operating data displayed varies depending on the language selected.

Total operation time h **3500**

Shows the total time the product has been powered.

Highest primary flow °C **51**

Shows the highest temperature that has been supplied to the heating circuit.

Energy el. total (kWh) **250**

Shows how much additional heat has been used.

Operation time /24 h:m **07:26**

Shows total operating time during the last 24 hours.

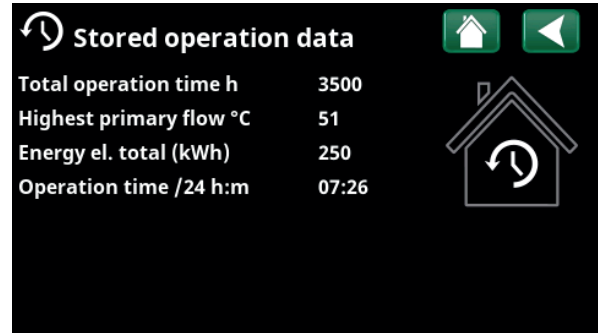

Menu: "Operation data/Stored operation data".



11.7.6 Operation data, DHW

Mode **Comfort**

Shows the active DHW program (Economy/Normal/Comfort).

Tank upper °C **45 (55) (65)**

Shows the current temperature in the DHW tank and the setpoint (in brackets) for heat pump operation and during additional heat.

When the Legionella protection function is active, "L" is displayed, e.g. "59 (60) (40) L".

Extra DHW **On**

"On" means the "Extra DHW" function is active.

DHW circulation **Off**

"On" means the "DHW circulation" function is active.

SmartGrid **Off**

The status of the SmartGrid functions for DHW is shown here.

DHW tank ext. °C **45**

Shows the temperature in the external DHW tank (if defined).

When the Legionella protection function is active, "L" is displayed, e.g. "45 (60) (40) L".

Pump ext. DHW tank **On**

Displays the status ("On"/"Off") of the charge pump for the external DHW tank (if defined).

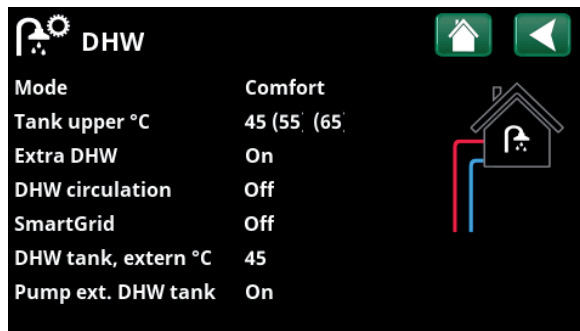

"Operation Data/DHW" menu.

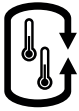

11.7.7 Operation data, External buffer tank

Status	Loading buffer tank
Shows the various operational statuses of the system, see table below.	
Ext. buffer tank upper °C	70
Indicates the current temperature in the upper part of the buffer tank.	
Ext. buffer tank lower °C	40
Indicates the current temperature in the lower part of the buffer tank.	
Tank upper °C	80
Shows the temperature in CTC EcoZenith's upper tank.	
Tank lower °C	40
Shows the temperature in CTC EcoZenith's lower tank.	
Charge start °C	60
Shows the temperature in the lower tank of the CTC EcoZenith when charging to the external buffer tank should start.	

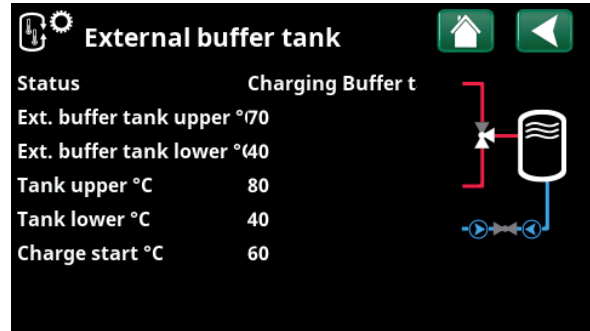

"Operation Data/External buffer tank" menu.

Status buffer tank	
Charging DHW	The buffer tank charges CTC EcoZenith's upper tank.
Loading Heating	The buffer tank charges the heating system.
Loading buffer tank	The buffer tank is charged from CTC EcoZenith's lower tank.
Off	No charging to/from the buffer tank.



11.7.8 Operation data, Wood boiler

System status	Heating
Shows the various operational statuses of the system, see the top table below.	
Status	On
The bottom table below shows possible statuses of the wood boiler.	
Tank upper °C	50
Shows the current temperature in CTC EcoZenith's upper tank.	
Wood boiler °C	70
Shows the temperature in the wood boiler.	
Charge start °C	70
Shows the temperature in the wood boiler when charging to CTC EcoZenith's lower tank should start.	
Flue gas °C	100
Shows the temperature of the flue gas flow if wood operation is active.	
Recharge delayed (min)	30
Time in minutes until recharging from external buffer tank is permitted.	

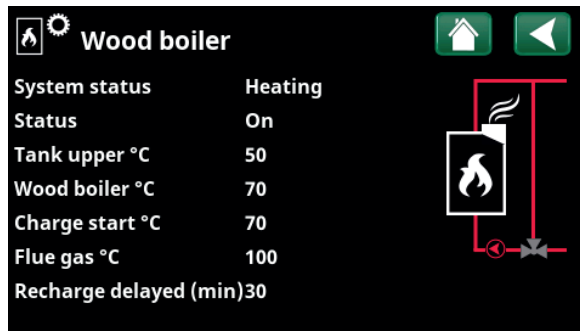

"Operation Data/Wood Boiler" menu.

System status, wood boiler	
DHW	Wood boiler producing hot water (DHW).
Heating	Wood boiler producing heat for the heating circuit (HC).
Wood	Wood operation active. Wood operation is activated when the flue gas temperature exceeds the set value and the temperature is equal to or above its reference value (setpoint). When wood operation is active, the heat pump or additional heat is not used for heating. Wood operation is also activated when the primary flow sensor (B1) is 10 °C above the setpoint.
Heating-Mixing	Heating is produced for the heating circuit (HC). Mixing valve Y1 works according to the setpoint of the primary flow sensor. If the boiler temperature is 10 °C higher than the primary flow setpoint, mixing valve Y1 will begin to adjust down to this temperature.
DHW + Heating	Wood boiler producing hot water (DHW) and heat for the heating circuit (HC).
Off	Wood boiler not activated.

Status, wood boiler	
Off	Wood boiler not active.
Standby	Wood boiler not producing heat; only "residual heat" is distributed.
On	Wood boiler active.

16400548-1



11.7.9 Operation data, External Boiler

Status	On
The external boiler may have the following status, see the table below.	
Temperature °C	60
Shows the temperature of the boiler.	
Tank upper °C	50
Shows the current temperature in CTC EcoZenith's upper tank.	
Recharge delayed (min)	70
Time in minutes until recharging from external buffer tank is permitted.	
Tariff ext. boiler	Off
"On" means that the function is activated via remote control or a schedule. Read more in the "Advanced/Define/Remote Control" chapter.	
SmartGrid	SG Block
"SG Block" indicates that the external boiler is blocked.	
Round circulation	Off
"On" means that the function is activated via remote control or a schedule.	

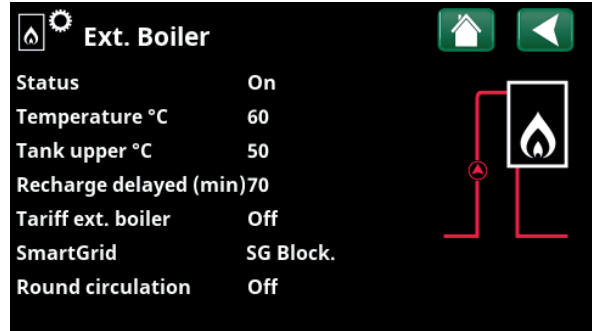

Menu "Operation Data/External boiler".

System status, External Boiler	
On	The external boiler is activated.
Off	The external boiler is not activated.
Start delay	The external boiler is prevented from starting due to the start delay.
Stopping	Boiler not producing heat; only "residual heat" is distributed.
Blocked	Operation of the external boiler is blocked by the system.



11.7.10 Operation data, Solar collectors

Status	Charging DHW
Shows status of solar collectors, see table below.	
Outlet °C	68
Shows the outgoing temperature from the solar collectors.	
Inlet °C	60
Shows the incoming temperature to the solar collectors.	
Solar collector pump %	46%
This shows the actual percent of maximum capacity for the circulation pump.	
Charge pump, Solar collector %	46%
This shows the actual percent of maximum capacity for the circulation pump.	
Charging solar/tank	DHW
Indicates whether the solar collectors are charging CTC EcoZenith's lower tank ("DHW") or the buffer tank ("Heating").	
Mixing valve	Close
Shows whether the mixing valve "opens" or "closes".	
Pump charge brine loop	Off
This shows the operating mode for the pump ("Off" or "On") for recharging the borehole/ground.	
Valve charge brine loop	Off
This shows the operating mode for the valve ("Off" or "On") for recharging the borehole/ground.	
Energy output (kWh)	354
Shows total (estimated) energy output.	
Energy output /24h (kWh)	0.0
Shows energy output in the last 24 hours.	
Power (kW)	0.0
Shows current power output.	

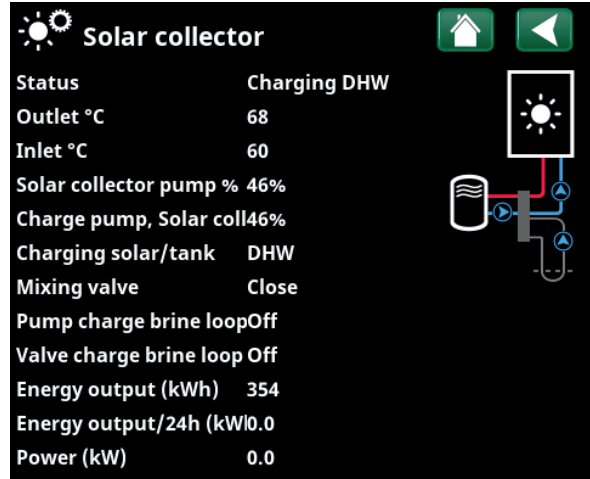

"Operation Data/Solar collectors" menu.

Status, solar collectors	
Solar collectors Off	Solar collectors are in operating mode "Off".
Charging Tank	Solar collectors are charging CTC EcoZenith's lower tank.
Charging Boiler	Solar collectors charging the wood boiler.
Charging DHW	Solar collectors charging the DHW system.
Charging Buffer tank	Solar collectors charging the buffer tank.
Test vacuum	Circulation through the solar collectors is started temporarily to check the collectors outgoing temperature.
Recharging borehole	Solar collectors recharging the borehole/ground.
Panel cooling/Tank cooling/ Antifreeze panel	Displayed when any protection function has been activated.

16400550-2



11.7.11 Operation data, Pool

Status Off

Shows the current operating status ("On", "Blocked" or "Blocked Externally").

- "Blocked" means that pool heating has been blocked from the "Advanced/Settings/Pool" menu.
- "Blocked ext." means that the pool is externally blocked via remote control or weekly program.

Pool temp °C 21 (22)

Shows the temperature in the pool and the setpoint that the system is working to achieve.

SmartGrid Off

The status of the SmartGrid functions for pool is shown here.

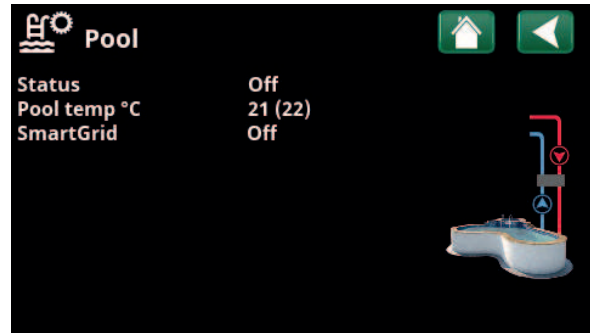

"Operation Data/Pool" menu.



11.7.12 Operation data, Ventilation

This menu is displayed if the "CTC EcoVent" ventilation product has been defined in the "Advanced/Define/Ventilation/EcoVent 2x" menu.

For more information, see the Installation and Maintenance Manual for CTC EcoVent.

Mode **Reduced**

Shows the current ventilation mode.

Setting options: Reduced / Forced / Normal / Custom.

Fan **20%**

Fan speed in %.

Highest level RH **40**

Highest measured value for humidity (%).

Displayed if RH sensor from the CTC SmartControl series is installed.

Refer to the Installation and Maintenance Manual for the CTC SmartControl accessory.

Highest CO₂ **550**

Highest measured value for carbon dioxide (ppm).

Displayed if the CO₂ sensor from the CTC SmartControl series is installed.

Refer to the Installation and Maintenance Manual for the CTC SmartControl accessory.

Forced **Off**

"On" means the fan enters "Forced" ventilation mode.

Days to service filter **86**

This shows the time in days remaining until the filter change.

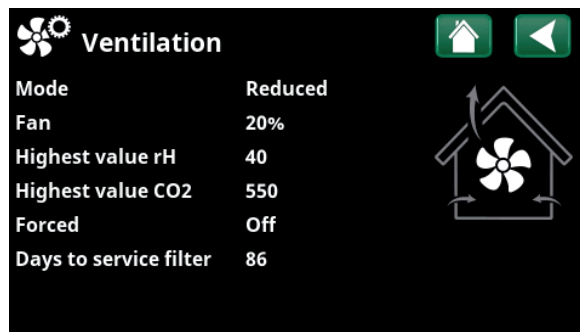

Menu: "Operation data/Ventilation".



11.7.13 Operation data, El.prices

This menu is displayed if "El.prices" has been defined in the "Advanced/Define/Communication" menu.

El.price mode **High**

Indicates the current price category ("High", "Medium" or "Low").

El.price/kWh **SEK 7.5**

Indicates the current electricity price in local currency.

Display the "Preview data" graph by clicking the "Graph icon" at the bottom-left of the menu screen.

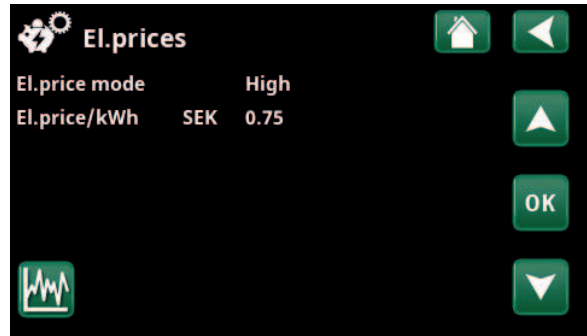

Menu: "Operation data/El.prices".

For more information and examples of Smart Electricity Price Control/SmartGrid, see the website www.ctc-heating.com/Products/Download.



11.7.14 External signal active

The menu shows the functions that are active via external control. The functions can be activated with:

- myUplink
- Virtuell digital in
- Modbus
- Relay
- SmartControl sensors

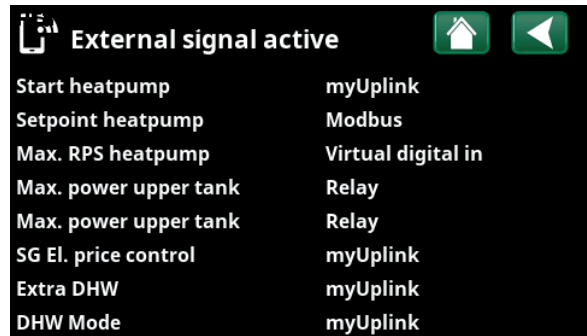

Menu: "Operation data/External signal active".

12. Advanced



This menu contains four sub-menus:

- Display
- Settings
- Define
- Service

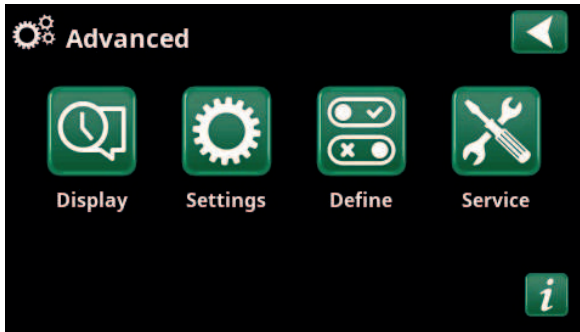

Menu: "Advanced".



For "System Information", click the "i" button in the lower right corner of the display in the "Advanced" menu. This displays the product serial number, MAC address, and application and bootloader versions. Click "Legal Information" to view information regarding third-party licences.



Menu: "Advanced/System information". To access this menu, click the "i" button in the lower right corner of the "Advanced" menu.

Scan the QR code with a tablet or smartphone. When your phone/tablet is connected to your local network, the product can be used with your device's touchscreen in the same way as the product's display.

12.1 Display



Time, language and other display settings can be carried out from this menu.

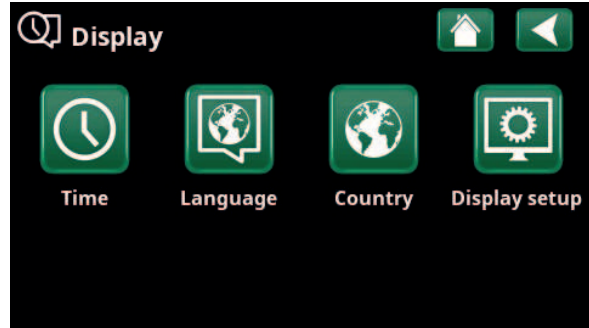

Menu: "Advanced/Display".

12.1.1 Time

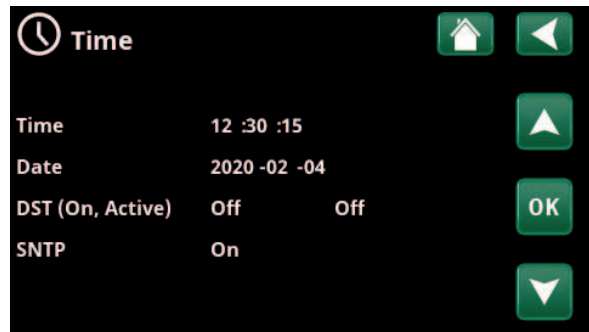

Menu: "Advanced/Display/Time".

Time and Date

Click on the time symbol. The menu can also be accessed by clicking the date or time in the upper right corner of the start page.

Press "OK" to highlight the first value and use the arrows to set the time and date.

DST (On, Active)

The left value can be set. "On" means the time is adjusted according to Summer Time.

The right value is fixed and shows the current status (for example, "Off" during the winter period). The display does not need to be connected to power for the values to be adjusted, since this occurs at the next start-up.

SNTP

Menu option "On" retrieves the current time from the internet (if online). More settings options can be found in the "Advanced/Settings/Communication/Internet" menu.

12.1.2 Language



Click a flag to select the language. The language selected is highlighted with a green square.

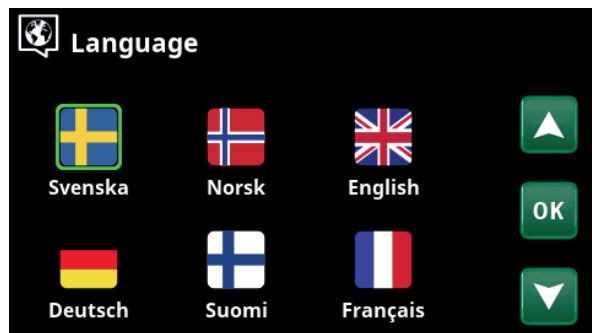

Menu: "Advanced/Display/Language".

To view more language options than those shown in the menu, scroll down the page, or press the down arrow key.

12.1.3 Country

Click on the "Country" symbol in the "Advanced/Display"



menu to display selectable countries and regions. The country that is displayed (highlighted in green) depends on which language has been selected.



Menu: "Advanced/Display/Country".

"English" is the default language setting, which means that "GB United Kingdom of Great Britain and Northern Ireland" is the default country setting.

Select the country where the plant is installed to get correct spot prices. Depending on which country is selected, product-specific factory settings may vary.

"Country" must also be selected to receive correct electricity prices when controlling electricity prices via the myUplink mobile app.

12.1.4 Display setup

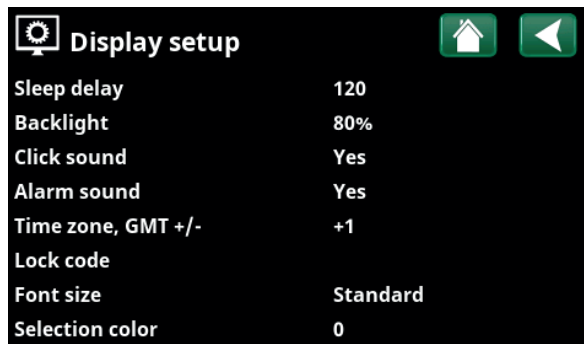

Menu: "Advanced/Display/Display setup".

Sleep delay **120 (Off, 1...360)**

Enter the time in minutes before the display enters sleep mode if not touched. Settings can be applied in 10 min. intervals.

Backlight **80% (10...90)**

Set the brightness of the backlit display.

Click sound **Yes (Yes/No)**

Enable or disable button sounds.

Alarm sound **Yes (Yes/No)**

Enable or disable alarm sounds.

Time zone, GMT +/- **+1 (-12...14)**

Set your time zone (relative to GMT).

Lock code **0000**

Press "OK" and use the arrows to set a 4-digit lock code. If a lock code is set, it is shown as four stars. You will be prompted to enter the code when the display is restarted.

NB: Make a note of the lock code for your own reference when you enter it in the menu for the first time.

The serial number of the display (12 digits) can also be entered to unlock the display (enter '0000' + serial number); see chapter "Advanced/System Information".

The display can be locked by clicking the product name in the upper left of the start menu, whereupon you will be prompted to enter the lock code.

A lock code can be deleted by entering "0000" in this menu instead of the previously specified lock code.

Font size **Standard (Small/Standard/Large)**

The display's font size can be changed here.

Selection colour **0 (0/1/2)**

Option to change the cursor background colour for clearer selection according to the light conditions.



12.2 Settings

Settings can be made here for, among other things, the house's heating and cooling needs. It is important that the basic heating setting is right for your home. Values which are set incorrectly may mean that your property is not warm enough or that an unnecessarily large amount of energy is being used to heat your property.

12.2.1 Settings, Heating circuit*

In the "Settings" menu, select "Heating circuit" and then the heating circuit to be set.

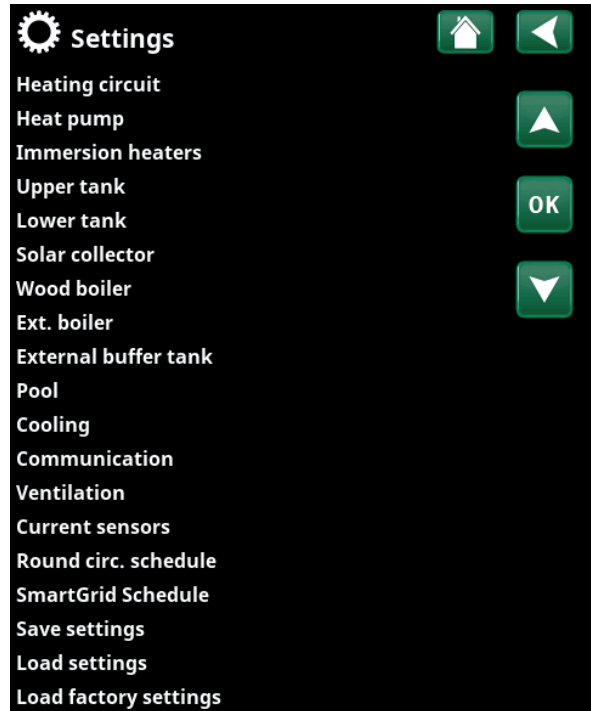

Menu: "Advanced/Settings".

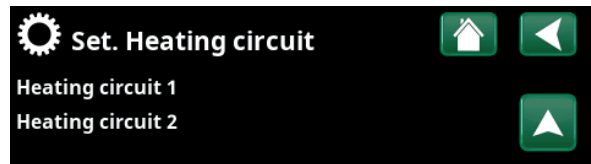

Part of the "Advanced/Settings/Heating Circuit" menu.

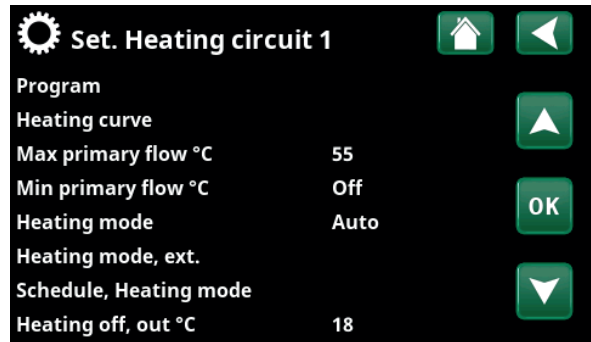

Part of the "Advanced/Settings/Heating Circuit/Heating Circuit 1" menu.

*CTC EcoZenith i555 can control up to three heating circuits.

Program

Press "OK" on the "Program" menu bar to make settings for the "Economy", "Comfort" and "Custom" heating programs. Selected programme is marked with an "X".

To activate a heating program or set a schedule, press the "Program" button from the "Heating/Cooling" menu, see chapter "Display settings".

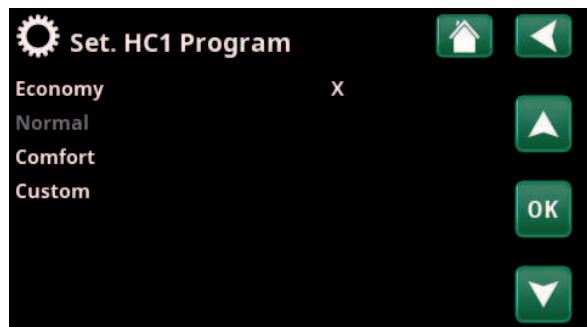

Menu "Advanced/Settings/Heating circuit/Heating circuit 1/Program".

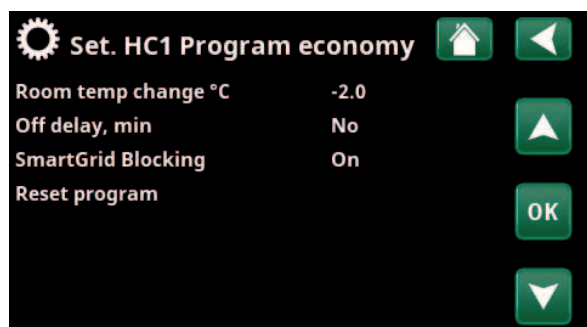

Menu "Advanced/Settings/Heating circuit/Heating circuit 1/Program/Economy".

• Primary flow change °C **-5 (-20...-1)**

The menu bar is displayed if the room sensor is not defined for the heating circuit. Setting "-5" (factory value program "Economy") means that the setpoint of the primary flow is lowered by 5 °C when the program is active.

• Room temp change °C **-2.0 (-5.0...-0.1)**

The menu bar is displayed if the room sensor is defined for the heating circuit. Setting "-2" (factory value program "Economy") means that the set setpoint for room temperature is lowered by 2 °C when the program is active.

• Off delay, min **No (No/10...600)**

Off delay means the time in minutes after the heating program "Economy", "Comfort" or "Custom" has been activated as the heating mode returns to the program "Normal".

However, if the "Custom" program is selected later than the "Normal" program, the "Custom" program will apply after the Off delay. The Off delay is adjusted in steps of 10 minutes for each key press (up or down arrow).

"No" means that the selected program will be activated until another heating program is activated.

• SmartGrid Blocking* **Off (Off/On)**

The menu bar is displayed when setting the heating programme "Economy" or "Custom".

"On" means that the heating program is activated when "SmartGrid Blocking" is active.

SmartGrid Low price* **Off (Off/On)**

The menu bar is displayed when setting the heating programme "Comfort" or "Custom".

"On" means that the room temperature is increased according to the setting for "SmartGrid Low price °C" when "SmartGrid Low price" is active.

SmartGrid Overcapacity* **Off (Off/On)**

The menu bar is displayed when setting the heating programme "Comfort" or "Custom".

"On" means that the room temperature is increased according to the setting for "SmartGrid Overcapacity °C" when "SmartGrid Overcapacity" is active.

• Reset program

Current program is reset with factory values.

*SmartGrid functions are set in the menu "Advanced/Settings/Heating circuit".

Heating curve

The heating curve determines the primary flow temperature (and thus the indoor temperature) to the heating circuit at different outdoor temperatures.

See chapter "House heating settings" for more information on adjusting the heating curve.

Possible choices are "Set. heating curve", "Fine adjustment", "Active curve", "Copy from ..." and "Reset curve".

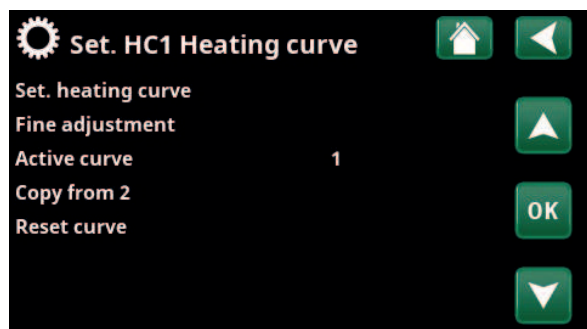

Menu "Advanced/Settings/Heating Circuit/Heating Circuit 1/Heating curve".

• Set. heating curve

The thicker line shows the factory-set curve while the thinner line shows the active heating curve to be reset.

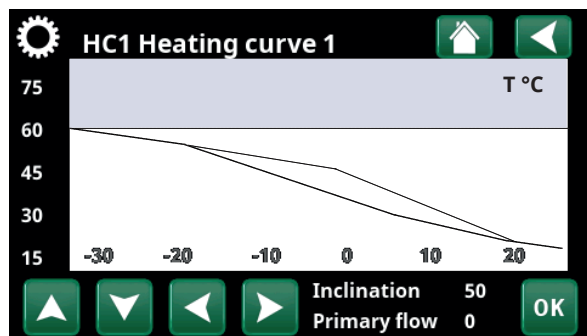

Menu "Advanced/Settings/Heating Circuit/Heating Circuit 1/Heating curve".

Here it is possible to adjust the appearance of the graph by adjusting the curve inclination and curve adjustment with the buttons below the graph. The adjustments you make here affect the entire appearance of the graph, while the changes made under "Fine adjustment" are made one point at a time. Curve inclination is adjusted with the left and right arrows while curve adjustment is adjusted with the up and down arrows. Confirm with "OK".

• Fine adjustment

The graph of the active heating curve for the heating circuit is displayed.

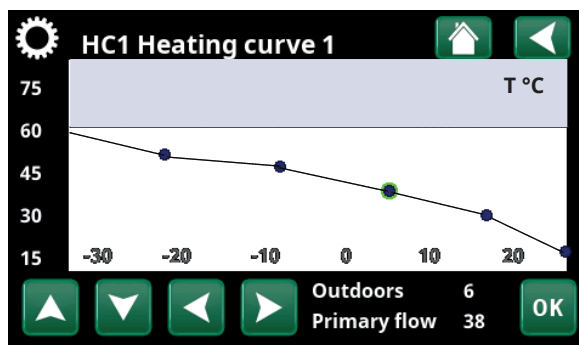

Menu "Advanced/Settings/Heating Circuit/Heating Circuit 1/Heating curve/Fine adjustment".

The heating curve can be adjusted in 5 points on the graph. Touch a point (becomes green) to change its position in the x-axis (outdoor temperature) and y-axis (primary flow temperature). Use the up/down/left/right buttons below the graph or press and drag the point.

Below the graph, the outdoor and primary flow temperatures for the selected point are shown. The heating curve can also be adjusted from the "Heating/Cooling" menu, see chapter "Display settings".

• Active curve 1 (1/2)

This menu bar shows the selected heating curve, it is possible to choose between two different heating curves per heating circuit.

• Copy from 1 (2)

The function "Copy from ..." is useful if you have created two different heating curve graphs but want to restore one graph to the same appearance as the other and then make changes.

Example: If heating curve 1 is selected as "Active curve", heating curve 1 will have the same appearance as heating curve 2 by selecting the line "Copy from 2" and pressing "OK". The menu bar cannot be selected (marked with gray) when heating curves 1 and 2 have the same values (the graphs look the same).

• Reset curve

Resets the active heating curve to the factory-set curve.

Max primary flow °C 55 (30...70)

Maximum permitted temperature supplied to the respective heating circuit.

Min primary flow °C Off (Off/15...65)

Minimum permitted temperature supplied to the respective heating circuit.

Heating mode Auto (Auto/On/Off)

Switching between heating season and summer mode can take place automatically (Auto) or a selection can be made here to set the heating to "On" or "Off". Heating mode can also be selected from the start page by pressing the "Mode" button in the Heating/Cooling menu.

- **Auto** = switching the heating season On and Off carried out automatically.
- **On** = Continuous heating season, the radiator pump circulates constantly.
- **Off** = there is no heating, the radiator pump does not run (is turned over).

Heating mode, ext. - (Auto/On/Off)

The heating mode selected in this menu can be enabled/disabled externally.

This menu bar is displayed for the current heating circuit if a remote control input or a schedule has been defined for the function.

Read more in the "Def. Remote Control" section of the "Installer/Define" chapter.

Schedule, Heating mode

This menu bar is displayed if a schedule has been defined for the "Heating mode, ext." function in the remote control menu.

For more information, refer to:

- chapter "Schedule".
- section "Def. Remote Control" of the "Installer/Define" chapter for defining the remote control function.

Heating off, out °C 18 (2...30)

Heating off, time (min) 120 (30...1440)

Heating on, time (min) 120 (30...1440)

The menu bars can only be set if the "Auto" mode is selected in the "Heating mode" menu above. Otherwise, the menu bars are locked (greyed out).

When the outdoor temperature exceeds (or equals) the set value in the "Heating off, out °C" menu during the time (in minutes) set in the "Heating off, time (min)" menu, the production of heat for the house is stopped.

This means the radiator pump stops, and the mixing valve remains closed. The radiator pump is activated daily for a short period to prevent it from jamming. The system restarts automatically when heating is needed.

When the outdoor temperature drops to the limit where heating is needed again, heat to the house is permitted when the temperature falls below (or equals) the set value in the "Heating off, out °C" menu for the number of minutes set in the "Heating on, time (min)" menu.

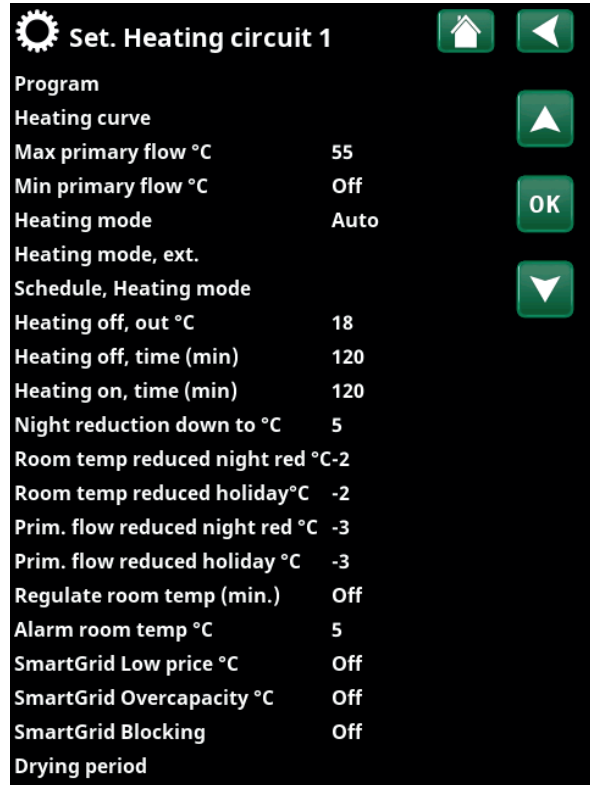

Menu "Installer/Settings/Heating Circuit/Heating Circuit 1".

Night reduction down to °C **5 (-40...40)**

When the outdoor temperature is lower than this, the "Night Reduction" function stops since too much energy is consumed and it takes too long to increase the temperature again.

This menu overrides remote control of "Night Reduction".

Room temp. reduced, Night red °C **-2 (0...-30)****Room temp. reduced, Holiday °C** **-2 (0...-30)**

The menus are displayed if room sensors are installed for the heating circuit. The number of degrees by which the room temperature should be lowered during remote-controlled night reduction and during holidays can be set here. Night reduction can also be set periodically; the temperature decrease is then entered in the schedule.

Prim. flow reduced, Night red °C **-3 (0...-30)****Prim. flow reduced, Holiday °C** **-3 (0...-30)**

The menus are displayed if room sensors are not installed for the heating circuit. The number of degrees by which the primary flow temperature for the heating circuit should be lowered during remote-controlled night reduction and during holidays can be set here. Night reduction can also be set periodically; the temperature decrease is then entered in the schedule.

Regulate room temp (min.) **Off (30...600)**

At the selected time interval, the system senses the current room temperature and regulates to reach the setpoint.

The time interval is set individually for each property, depending on insulation and heat transfer (well insulated = longer time, poorly insulated = shorter time).

Alarm room temp °C **5 (-40...40)**

If the room temperature is too low (according to the set value), the message "Alarm, low room temp." will be displayed.

This menu bar is displayed if the room sensor is connected and defined.

SmartGrid Low Price °C **Off (Off/1...5)**

Setting to increase the room temperature at "Low price" energy price, via SmartGrid.

Both SmartGrid A and SmartGrid B must be defined in the remote control menu for this menu to be displayed.

Read more in the "Remote Control/SmartGrid A/B" section of the "Installer/Define" chapter.

SmartGrid Overcapacity °C **Off (Off/1...5)**

Setting to increase the room temperature at "Overcapacity" energy price, via SmartGrid. This function is not used for electricity price control.

Both SmartGrid A and SmartGrid B must be defined with a remote control input for this menu to be displayed.

Read more in the "Remote Control/SmartGrid A/B" section of the "Installer /Define" chapter.

● If room sensors are installed, the "Room temp reduced..." menu is displayed. If there are no room sensors, the "Primary flow reduced..." menu is displayed.

Example

As a rule, a "Primary flow reduced" reduced value of 3 to 4 °C is equivalent to a reduction of approximately 1 °C in room temperature in a normal system.

SmartGrid Blocking **Off (Off/On)**

"On" means the heating circuit is blocked at "High" energy price, via SmartGrid. If the outdoor temperature falls below the value set in the "Night reduction down to °C" menu, this function is not activated.

Both SmartGrid A and SmartGrid B must be defined with a remote control input for this menu to be displayed.

Read more in the "Remote Control/SmartGrid A/B" section of the "Installer /Define" chapter.

Drying period

Floor drying function for newly built properties. The function limits the calculation of primary flow temperature (setpoint) for "House heating settings".

For more information, see section "Def. Remote control" in chapter "Advanced/Define".

The floor drying function is scheduled and selected from 3 preset modes.

Create schedule

Fill in the wanted start date + time, select mode and temperature.

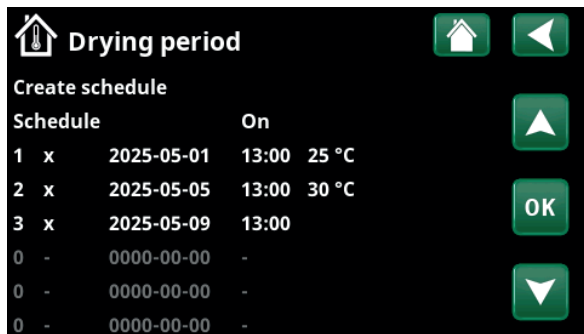

Menu "Advanced/Settings/Heating circuit/Heating circuit 1/Drying period".

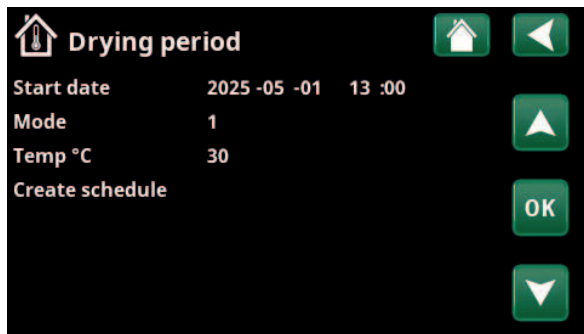

Menu "Advanced/Settings/Heating circuit/Heating circuit 1/Drying period/Create schedule".

• Mode 1: 8 days

1. The setpoint of the heating circuit is set to 25 °C for four days.
2. On days 5-8 the set value 'Temp °C' is used. From day 9 onwards, the value is automatically calculated according to the "House heating settings".

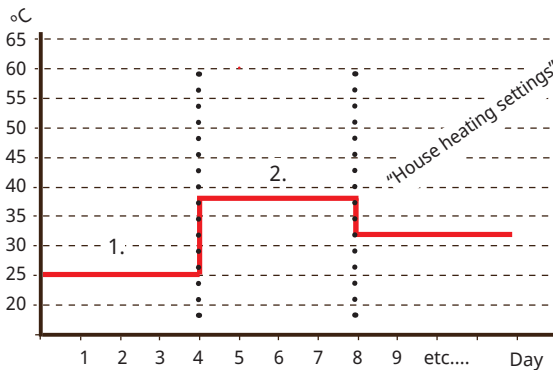

Example: Mode 1 with set value for "Temp °C": 38.

• Mode 2: 10 days + stepped increase and decrease

1. Stepped increase start: The setpoint of the heating circuit is set to 25 °C. Then the setpoint is increased by 5 °C every day until the setpoint is equal to 'Temp °C' (last step can be less than 5 °C).
2. Floor drying function for 10 days.
3. Stepped decrease: Setpoint is lowered to 25 °C by 5 °C per day (last step can be less than 5 °C). After stepped decrease and 1 day with setpoint 25 °C, the value is automatically calculated according to the "House heating settings".

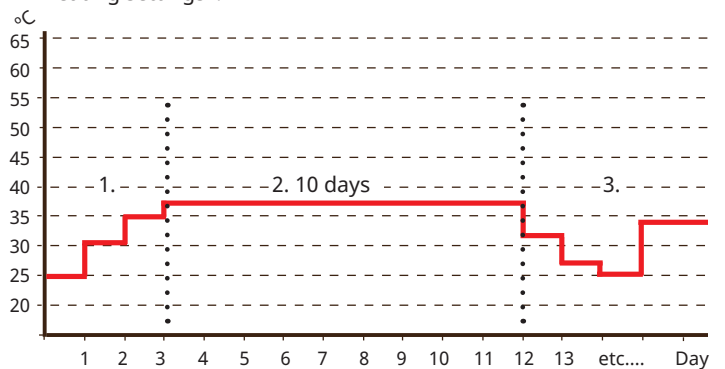

Example: Mode 2 with set value for "Temp °C": 37.

• Mode 3

This mode means that the function starts with "Mode 1", followed by "Mode 2" and then "House heating settings".

Temp °C 5 (25...55)

Set the temperature for "Mode 1/2/3".

Create schedule

Select "Create schedule" and confirm with "OK".

Schema Off (Off/On/Load factory settings)

Select "On" to activate a schedule.

Select "Load factory settings" to reset a schedule to zero.

The current period (schedule) is shown in green text.

Drying period (Heating circuit 2-) Off (Off/On)

The menu bar is displayed for heating circuit 2- if the floor function has been defined for heating circuit 1 as described above.

"On" means that the floor drying mode selected for heating circuit 1 will also run for the selected heating circuit.

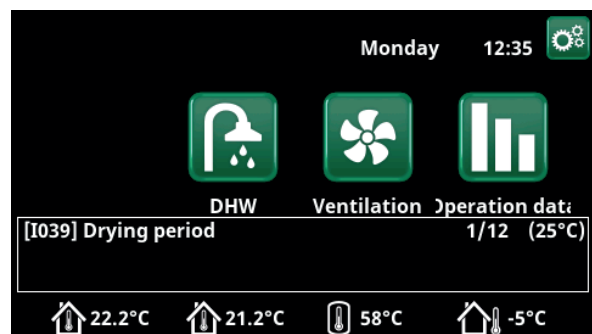

Example: Drying period day 1 of 12 with current set point of 25 °C.

12.2.2 Settings, Heat pump

In the "Heat pump" menu you make settings for the heat pumps which have been defined.

Delay between HP **30 (5...180)**

The delay time between when two heat pumps can start is set here. This value applies, for example, to the amount of time that will pass before the third heat pump can start, when the first and second heat pumps are operating, and so on.

During incrementing/decrementing using a smaller heat pump with lower output, half the set value is counted.

The menu bar is only displayed for Heat pump 1*.

Delay primary flow temp. (sec.) **180 (20...300)**

The charge temperature is high after DHW charging. During the set time period, the primary flow temperature is ignored.

Prio A/W °C **7 (-20...15)**

This temperature setting controls prioritisation during heat production between the air-to-water and liquid-to-water heat pumps if both types are connected to the system. The default value is 7 °C, which means that the air-to-water heat pump is prioritised for outside temperatures from 7 °C and warmer.

The menu bar is only displayed for Heat pump 1*.

SmartGrid Blocking HP **No (No/Yes)**

"Yes" means that the heat pump is blocked when "SmartGrid Blocking" is active.

Defrost heating temp min m **10 (0...360)**

Set the minimum heating time "Min m" (minutes) for the heating coil in the condensation tray at outdoor temperature T1.

Defrost heating temp max m **10 (0...360)**

Set the maximum heating time "Max m" (minutes) for the heating coil in the condensation tray at outdoor temperature T2.

Defrost heating temp min °C **10 (-40...40)**

When the outdoor temperature is this or higher (T1), the heating time is regulated down to the value set in the menu "Defrost heating temp min m".

Defrost heating temp max °C **-10 (-40...40)**

When the outdoor temperature is this or lower (T2), the heating time is regulated up to the value set in the menu "Defrost heating temp max m".

Heat pump 1-*

Apply settings for each heat pump. Refer to the "Settings/Heat pump 1-" chapter.

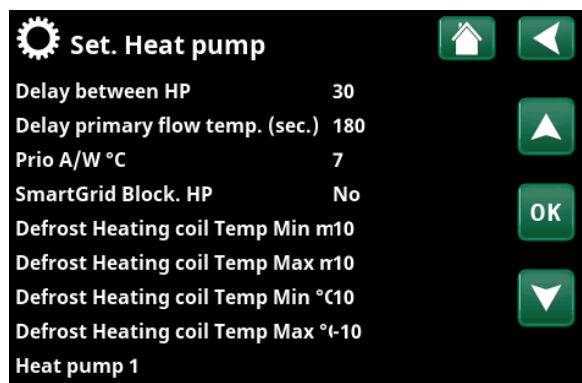

Menu: "Advanced/Settings/Heat Pump".

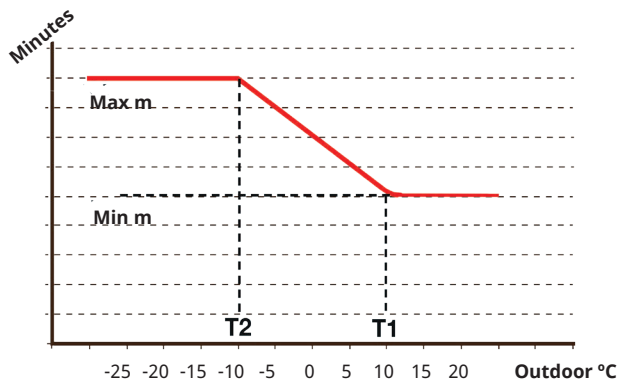

The diagram shows that the heating time of the heating coil to the condensation trays is regulated depending on the outside temperature.

When the outdoor temperature is below T2, the heating time adjusts up to "Max m".

When the outdoor temperature exceeds T2, the heating time adjusts down to "Min m".

These temperatures and times are set in the menus "Defrost heating temp..." on the left.

*CTC EcoZenith i555 can control up to 3 CTC heat pumps and 3 heating circuits simultaneously.

12.2.3 Settings, Heat pump 1-**

Compressor **Blocked (Permitted/Blocked)**

The heat pump is supplied with a blocked compressor. "Permitted" means that the compressor is allowed to start.

Stop at outdoor °C **-22 (-22...10)**

This menu relates to settings for the outdoor temperature at which the compressor is no longer permitted to operate. The heat pump starts 2°C above the set value. Only applies to air-to-water heat pumps.

Charge pump % **50% (20...100)**

The speed of the charge pump is set here.

Cold temp limit **0 (0...-15)**

Temperature limit for "winter power". When the outdoor temperature is equal or lower (T2), the compressor speed is adjusted up to speed R2. Only applies to modulating air-to-water heat pumps.

Max RPS **120* (50...120)**

The maximum permissible speed of the compressor at "winter temperature". Sets the compressor's maximum speed (R2) at outdoor temperature T2. Only applies to modulating air-to-water heat pumps.

Warm temp limit **20 (0...20)**

Temperature limit for "summer power". When the outdoor temperature is equal or higher (T1), the compressor speed is adjusted down to speed R1. The heat pump starts and stops at the actual value and setpoint value. Only applies to modulating air-to-water heat pumps.

Max RPS warm temp **50 (50...120)**

The maximum permissible speed of the compressor at "summer temperature". Sets the compressor's maximum speed (R1) at outdoor temperature T1. Only applies to modulating air-to-water heat pumps.

Ext. noise reduction RPS **50 (20...120)**

Set the compressor speed value applicable for remote control. Read more in the "Def. Remote Control" section of the "Installer/Define" chapter.

Noise reduction, schedule

This menu starts a schedule with limited compressor speed to reduce the noise level. The "Schedule" chapter describes how to set schedules.

Compressor stop at brine °C **-5 (-15...10)**

Specify the brine temperature at which the compressor should stop. Only applies to liquid-to-water heat pumps.

Brine pump **Auto (Auto/10 days/On)**

After installation is complete, you can choose to run the brine pump constantly for 10 days to remove air from the system. The brine pump then enters "Auto" mode. "On" means the brine pump runs constantly.

Only applies to liquid-to-water heat pumps.

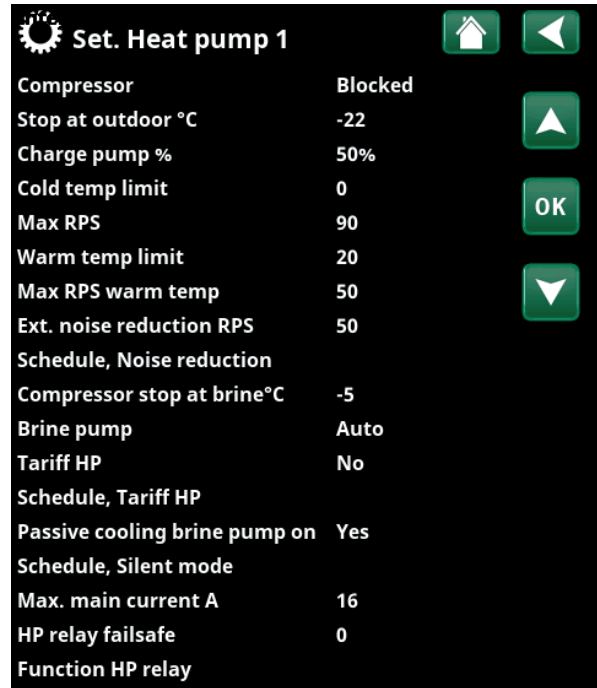

Menu: "Installer/Settings/Heat Pump/Heat Pump 1-".

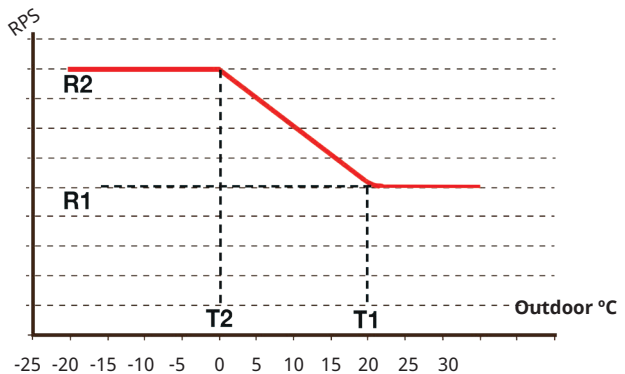

The diagram shows that the compressor speed is controlled according to the outside temperature. When the outside temperature is below T2, the compressor speed adjusts up to R2. When the outside temperature exceeds T1, the compressor speed adjusts down to R1.

These temperature and speed limits are set in the menus on the left.

*The value may vary depending on the heat pump model.

**CTC EcoZenith i555 can control up to 3 CTC heat pumps and 3 heating circuits simultaneously.

Tariff HP **No (No/Yes)**

"Yes" means the function can be activated via remote control.

Read more in the "Def. Remote Control" section of the "Installer/Define" chapter.

Schedule, Tariff HP

This menu bar is displayed if a schedule has been defined for the "Tariff HP" function.

For more information, refer to:

- chapter "Schedule".
- section "Def. Remote Control" of the "Installer/Define" chapter for defining the remote control function.

Passive cooling brine pump On **Yes (Yes/No)**

Enable "Yes" if the brine pump should be used for passive cooling.

Only applies to liquid-to-water heat pumps.

Schedule, Silent mode

It is possible to start a schedule, e.g. during the night, with limited compressor speed and fan speed to reduce the noise level.

The "Schedule" chapter describes how to set schedules.

Only applies to CTC EcoAir 600M/700M.

Max. main current A **16*****

Setting the maximum allowed main current for the heat pump.

Only applies to CTC EcoAir 700M.

***Factory setting: EA712M/EA708M, 1x230V: 16A
EA712M/EA708M, 3x400V: 13A
EA720M, 3x400V: 20A

HP relay failsafe **0 (0...7)**

Setting the fail-safe mode (bit 0-7). Currently, bit 0 and bit 1 are implemented as follows:

- bit 1: The relay closes (signal on output "External out 1/C7" on the heat pump circuit board) in case of communication failure between the display and the heat pump.
- bit 0: The relay does not close in case of communication failure between the display and the heat pump.

Only applies to CTC EcoAir 700M.

Function HP relay - (Alarm HP/All alarms/Compr. on)

The following settings are possible:

- **Alarm HP:** The relay closes (signal on output "External out 1/C7" on the heat pump control board) in case of an alarm on the heat pump.
- **All alarms:** the relay closes for all alarms on the system.
- **Compr. on:** the relay closes when the compressor is running.

Only applies to CTC EcoAir 700M.

Factory setting: no value is set.

12.2.4 Settings, Immersion heater

Upper immersion heater(s) kW

(3x400V)	8.7 (0.0...18.0)
(3x230V)	8.2 (0.0...8.2)
(1x230V)	8.0 (0.0...9.0)

Here you select the power that the upper immersion heaters are allowed to emit.

For language choices "German" and "French" the max electric power is factory set at 0.0 kW.

Lower immersion heater kW*

(3x400V)	4.7 (0.0...9.0)
(3x230V)	4.7 (0.0...4.7)

Here you select the power that the lower immersion heaters are allowed to emit

For language choices "German" and "French" the max electric power is factory set at 0.0 kW.

Lower immersion heater °C **30 (30...60)**

Setting of temperature for the lower immersion heater. The lower immersion heater is only allowed to operate when the heat pump is blocked for some reason.

Delay mixing valve **180 (30...240/Blocked)**

The mixing valve delay is set here, i.e. the period before it draws energy from the upper tank. The mixing valve can be blocked so that it never draws heat from the upper part of the tank.

When "Round circulation" or "SmartGrid blocking mixing valve" is activated, the mixing valve is blocked so that it cannot open to draw heat from the upper tank. If the mixing valve for the upper tank has opened when these functions are activated, it can continue to draw heat from the upper tank.

Main fuse A **20 (16...90)**

The size of the house's main fuse is set here. Together with the installed current sensors, the fuses are protected when using appliances which generate temporary power peaks, for example, cookers, ovens, engine heaters, etc., in which case the product temporarily reduces the connected electrical power.

Conv. factor curr. sensors **1 (1...10)**

This menu contains the factor the current sensor is to use. This setting is only performed if the connection has been installed for a current sensor for higher currents.

Example: User (set) value 2 => 16 A will be 32 A.

Tariff EL **No (Yes/No)**

This menu bar is displayed if an "Input" for remote control is defined for the "Tariff EL" function in the "Advanced/Define/Remote Control" menu.

"Yes" means the function can be activated via remote control.

Read more in the "Advanced/Define/Remote Control/Tariff EL" chapter.

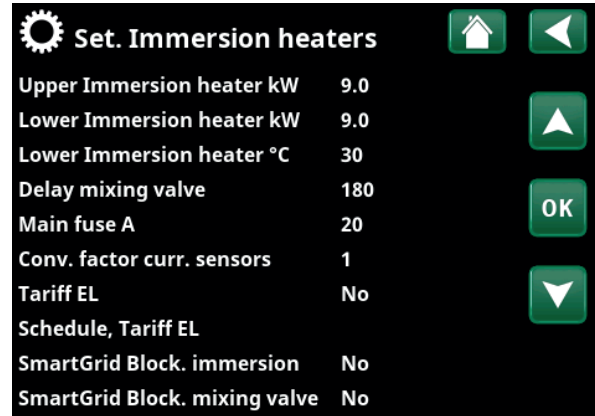

Menu: "Advanced/Settings/Immersion heater".

Schedule, Tariff EL

This menu bar is displayed if a "Schedule" is defined for the "Tariff EL" function in the "Advanced/Define/Remote Control" menu.

For more information, refer to:

- chapter "Schedule".
- section "Def. Remote Control" of the "Advanced/Define" chapter for defining the remote control function.

SmartGrid Block. immersion **No (Yes/No)**

For this menu to be displayed, define a remote control input for both SmartGrid A and SmartGrid B.

"Yes" means that the additional heat is blocked when "SmartGrid Blocking" is active.

Read more in the "Advanced/Define/Remote Control" chapter.

SmartGrid Block. mixing valve **No (Yes/No)**

The menu bar is displayed if the "SmartGrid block immersion" selection on the row above is "Yes".

When blocked, the mixing valve for the heating circuit does not open more than 50% if the need arises.

"Yes" means the function can be activated via remote control.

*The menu bar is not displayed at 1x230V.

12.2.5 Settings, Upper tank

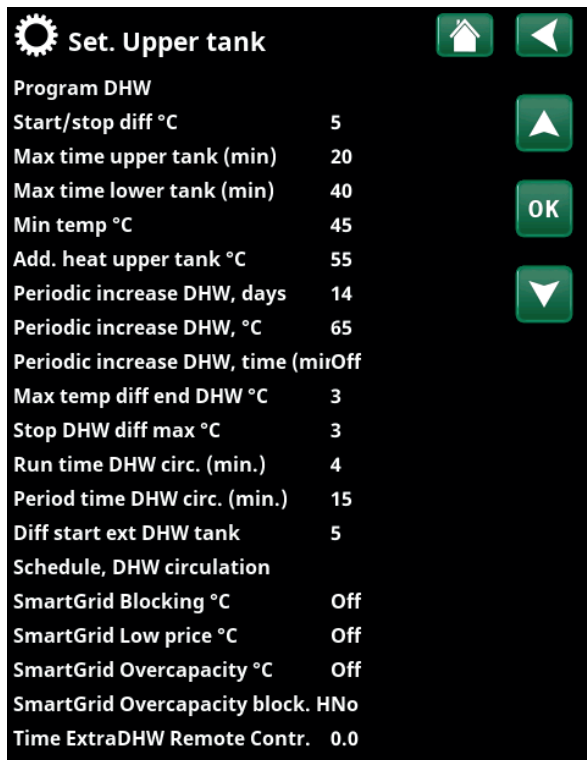

Menu: "Advanced/Settings/Upper tank".

Program DHW

Available options are "Economy", "Normal" and "Comfort".

Press "OK" to open the settings for the selected DHW program. The factory settings shown below apply to "Normal" mode. Refer to the "Parameter List" chapter for the "Economy" and "Comfort" modes' factory settings.

• Stop temp HP °C 55 (20...60)

At the selected temperature, the heat pump stops charging the DHW tank.

• Extra DHW stop temp °C 60 (20...62)

This menu is used to specify the setpoint for the heat pump to charge DHW.

• Reset program

The current DHW program will be restored to factory settings.

Start/stop diff °C 5 (3...7)

This menu is used to set the negative hysteresis before the heat pump starts charging the DHW tank after the setpoint has been reached.

Example: If the stop temperature is 55 °C and hysteresis is set to 5 °C in this menu, it means the heat pump will start DHW charging again when the temperature in the tank has dropped to 50 °C.

Max time upper tank (min) 20 (5...60)

The maximum time that the heat pump charges the upper tank if it is needed in the lower tank is specified here.

Only applies to CTC EcoAir 400 and CTC EcoPart 400 heat pumps.

Max time lower tank (min) 40 (5...60)

The maximum time that the heat pump charges the lower tank if it is needed in the upper tank is specified here.

Only applies to CTC EcoAir 400 and CTC EcoPart 400 heat pumps.

Min. temp °C 45 (35...55)

This menu is used to specify the lowest permitted temperature in the upper tank.

Add. heat upper tank °C 55 (45...80)

Stop temperature for additional heat from immersion heater/external boiler. Used when the CTC EcoZenith is in additional heating status, and only when the mixing valve delay has counted down. The mixing valve delay does not apply if a heat pump is not available.

Periodic increase DHW, days 14 (Off/1...30)

The menu defines the interval of the periodic increase of the hot water for legionella protection.

1 = Every day, 2 = Every other day, 3 = Every third day, etc...

Periodic increase DHW, °C 65 (57...65)

Set the temperature for the periodic increase.

Periodic increase DHW, time (min) Off (Off/1...60)

Set the number of minutes for how long the set temperature will be exceeded.

Max temp diff end DHW °C 3 (2...7)

If there is a heating requirement, DHW charging is interrupted before maximum temperature is reached, in order to avoid the compressor stopping while switching DHW to heating.

Stop DHW diff max °C 3 (2...10)

DHW charging is normally interrupted in the DHW sensor, but this can also occur in the condensation temperature which is calculated based on the heat pump's internal pressure sensor. The condensation temperature is significantly increased during DHW charging. This menu relates to the value from the maximum permitted condensation temperature that interrupts DHW charging. If there is a heating requirement, the system then diverts to charging the heating circuit.

Run time DHW circ. (min) 4 (1...90)

The length of time that DHW circulation should active during each period. Displayed if "DHW circulation" has been defined in the "Advanced/Define/DHW tank" menu.

Period time DHW-circ. (min) 15 (5...90)

Time between periods of DHW circulation. Displayed if "DHW circulation" has been defined in the "Advanced/Define/DHW tank" menu.

Diff start ext. DHW tank 5 (3...15)

This menu is used to select the temperature difference at which the charging of the external DHW tank is required to start. The difference is specified in relation to the setpoint that is set in the "DHW Program/Stop temp HP °C" menu.

Schedule, DHW circulation

This menu displays the scheduled weekday periods when the DHW circulation pump is to run. The menu bar is displayed if:

- "DHW circulation" has been defined in the "Advanced/Define/DHW tank" menu.
- a "Schedule" is defined for the DHW Circulation" function in the "Advanced/Define/Remote Control" menu.

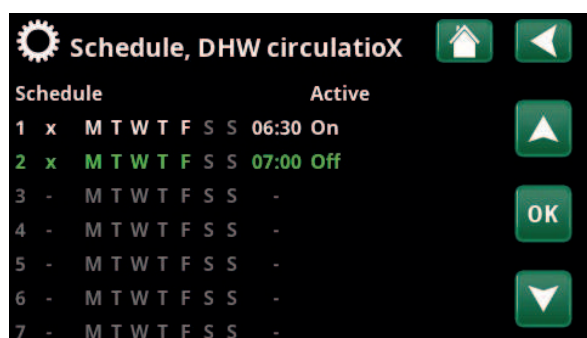

Menu: "Advanced/Settings/DHW Tank/Schedule, DHW circulation". In the example above, "DHW circulation" is activated every week - Monday to Friday between 06:30 and 07:00.

For more information, refer to:

- chapter "Schedule".
- section "Def. Remote Control" of the "Advanced/Define" chapter for defining the remote control function.

SmartGrid Blocking °C Off (Off/-1...-50)

The setpoint for DHW tank heating is decreased by the value set in this menu when "SmartGrid Blocking" is active.

Both SmartGrid A and SmartGrid B must be defined in the remote control menu for this menu to be displayed. Read more in the "Def. Remote Control/SmartGrid A/B" section of the "Advanced/Define" chapter.

SmartGrid Low price °C Off (Off/1...30)

The setpoint for DHW tank heating is increased by the value set in this menu when "SmartGrid Low price" is active.

Both SmartGrid A and SmartGrid B must be defined in the remote control menu for this menu to be displayed. Read more in the "Def. Remote Control /SmartGrid A/B" section of the "Advanced/Define" chapter.

SmartGrid Overcapacity °C Off (Off/1...30)

The setpoint for DHW tank heating is increased by the value set in this menu when "SmartGrid Overcapacity" is active.

Both SmartGrid A and SmartGrid B must be defined with a remote control input for this menu to be displayed. Read more in the "Def. Remote Control /SmartGrid A/B" section of the "Advanced/Define" chapter.

SmartGrid Overcapacity block HP No (No/Yes)

"Yes" means that DHW tank heating using the heat pump is blocked when "SmartGrid Overcapacity" is active.

Time ExtraDHW Remote Control 0.0 (0.0...10.0)

Set the time (hours) that the production of additional hot water to the DHW tank should continue. The 'Extra DHW' function is activated via the remote control.

The menu bar is displayed if:

- a normal mode for the external control signal (Normally Open (NO)/Normally Closed (NC)) is defined for the function in the "Advanced/Define/DHW Tank" menu.
- an "Input" for "Extra DHW" has been defined in the "Advanced/Define/DHW tank" menu.

12.2.6 Settings, Lower tank

Tank max °C 55 (20...70)

This menu is used to set the highest temperature required for the lower tank.

Tank min °C 30 (5...60)

This menu is used to set the lowest temperature required for the lower tank.

Diff tank vs. primary °C 0 (0...15)

This menu is used to set the preferred difference between the temperature in the lower tank and the outgoing primary flow temperature to the heating circuit.

Start/Stop diff tank °C 5 (3...10)

The hysteresis between the heat pump's start and stop conditions in charging the lower tank. The heat pump starts when the DHW temperature is below the start value with the set difference.

Setpoint schedule °C 50 (20...60)

This menu is used to set the setpoint to which the lower tank works during external activation (remote control) and when programming a heating schedule.

This menu bar is displayed if a "Schedule" has been defined for the "Lower Tank" function.

For more information, refer to:

- chapter "Schedule".
- section "Def. Remote Control" of the "Advanced/Define" chapter for defining the remote control function.

Lower tank schedule

This menu bar is displayed if a "Schedule" is defined for the "Lower Tank" function in the "Advanced/Define/Remote Control" menu.

For more information, refer to:

- chapter "Schedule".
- section "Def. Remote Control" of the "Advanced/Define" chapter for defining the remote control function.

SmartGrid Low price °C Off (Off/1...30)

The setpoint increase for heating the lower tank when "SmartGrid Low Price" is active can be set here.

When the function is active, overcharging can take place from the lower tank to the external buffer tank.

Read more in the "Advanced/Define/Remote control/SmartGrid" menu.

SmartGrid Overcapacity °C Off (Off/1...30)

The setpoint increase for heating the lower tank when "SmartGrid Overcapacity" is active can be set here.

When the function is active, overcharging can take place from the lower tank to the external buffer tank.

Read more in the "Advanced/Define/Remote control/SmartGrid" menu.

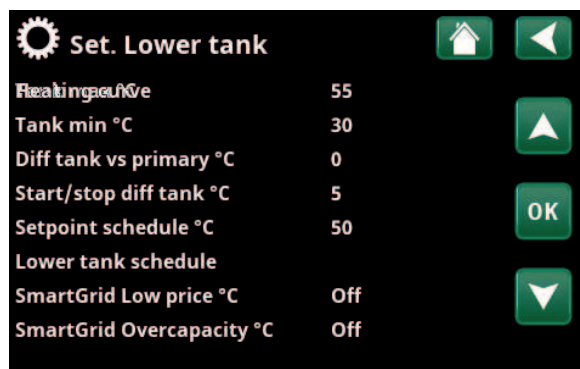

Menu: "Advanced/Settings/Lower Tank".

12.2.7 Settings, Solar collectors

dT max solar °C 7 (3...30)

Here you can set the temperature difference determining when charging of solar energy is started.

Type defined as "Coil". When the solar collectors are this many degrees warmer than the solar coil in the CTC EcoZenith, the solar collectors' circulation pump (G30) starts.

Type defined as "Heat exchanger". When the solar collectors are these many degrees warmer than the lower tank in the CTC EcoZenith, the solar collectors' circulation pumps (G30) start.

Solar is always charged primarily in the lower tank. If enough solar energy and temperature are present, they are transferred to the upper tank via the heat distribution pipes.

dT min solar °C 3 (2...20)

When the temperature difference above falls to this set value, the circulating pump (G30) for the solar collectors stops and the solar energy charge to the lower tank is terminated.

Min speed pump % 30 (30...100)

Setting for the minimum permissible rpm (in percent) for the solar collectors' circulation pump.

Max lower tank °C 85 (10...95)

The maximum permitted temperature in the lower tank. Charging of the lower tank ceases once the set temperature has been reached.

Max temp. brine °C 18 (1...50)

Setting for maximum permitted brine temperature. This menu shows if the function "Recharge borehole" has been selected in the "Advanced/Define/Solar collectors" menu. Solar charging of the borehole ceases when this value has been reached.

dT max borehole °C 60 (3...120)

Setting for start conditions for solar charging of borehole. Specifies the temperature difference (solar collectors-borehole) at which charging begins.

dT min borehole °C 30 (1...118)

Setting for stop conditions for solar charging of borehole. Specifies the temperature difference (solar collectors-borehole) at which charging stops.

Solar test tank (min) 4 (1...20)

(Used only if evacuated tube solar collectors have been defined.) When recharging the borehole, switching to tank charging is done once every 30 minutes to check whether tank charging is possible. The test is carried out at the set time interval. If enough temperature is obtained, tank charging continues; otherwise the system switches to charging the borehole again.

Test frequency min 30 (0...180)

Specifies the frequency at which the Solar Test function should perform. With 0 as the set value, solar test takes place continuously.

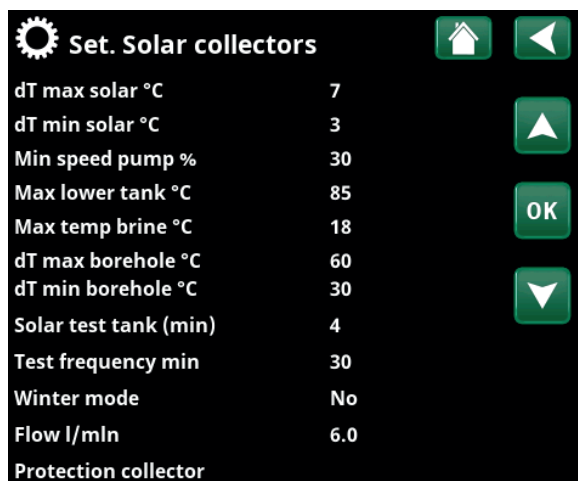

Menu: "Advanced/Settings/Solar collectors".

Winter mode (Off/On)

Winter mode is a setting which does not permit the CTC EcoZenith to check whether charging of solar energy to the lower tank is possible.

In winter, the CTC EcoZenith normally retains a higher temperature and the sun emits less energy and lower temperatures. To check whether charging of solar energy to the tank is possible, water must circulate in the system and the temperatures must be compared. If the check indicates that charging is not possible, energy will have been used unnecessarily by having the water circulate. The winter mode setting prevents this check. "Off" deactivates the Solar Test Tank function. Charging is carried out to the borehole only.

"On" Permits the Solar Test Tank function and charging of the CTC EcoZenith is possible.

Flow l/min 6.0 (0.1...50.0)

The flow circulating through the solar collectors should be indicated here. (This can be read from the flow meter in the system unit.) The flow should be read when pump G30 is running at 100%.

NB! It is important the value is correct, as the flow is used as the basis for calculating the power and cumulative energy. Incorrect flows will therefore produce incorrect values for these parameters.

Protection collector

See chapter "Settings, Protection collector".

12.2.7.1 Settings, Protection collector

Emergency cooling Yes (Yes/No)

Permits circulation to the CTC EcoZenith as well as the borehole. This is in order to prevent excessively high temperatures in the solar collectors. Applies once the maximum permitted temperature has been reached. For safety reasons, the temperature in the CTC EcoZenith is never allowed to exceed 95 °C.

Max temp °C 120 (110...150)

Protects the solar collectors from high temperatures by allowing circulation in the solar collectors even though the maximum temperature has been reached in the respective tank. For safety reasons, the temperature in the CTC EcoZenith is never allowed to exceed 95°C.

Re-cooling No (Yes/No)

This option can be activated when the emergency cooling function has been activated. The function means that the system endeavours reduce the temperature in the hot water and buffer tank to the set setpoint (set in the *Re-cooling to temp.* menu). This means that the solar collectors are used as cooling elements for a short period of time.

Re-cooling to temp °C 70 (50...80)

This option can be activated when the "Recooling" function has been activated. The function means that the system endeavours reduce the temperature in the DHW tank and buffer tank to the set setpoint.

Freeze protection No (No/Yes)

As there is a risk of blocks of ice forming in the solar collectors, circulation may be started to reduce the risk of frost damage.

Freeze protection °C -25 (-30...-7)

Specifies the temperature at which frost protection should be activated.

The menu bar is displayed when the "Freeze protection" function has been activated.

Re-cooling stop delay (min) 10 (0...180)

Delay refers to the time (minutes) before the need for re-cooling (DHW tank and buffer tank) ceases.

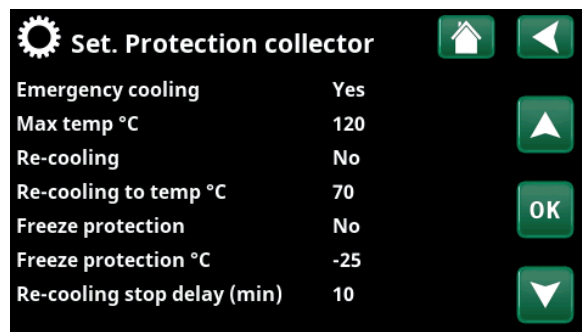

Menu: "Advanced/Settings/Solar collectors/Protection collector".

12.2.9 Settings, External boiler

Ext. boiler diff °C 5 (3...20)

The value by which the temperature is allowed to drop below the stop temperature before the external boiler starts again is set here.

Minimum boiler temp. °C 30 (10...80)

The temperature at which the circulation pump will begin charging is set here.

This menu bar is only displayed if the temperature sensor in the boiler has been defined (refer to the "Advanced/Define/External Boiler" menu).

Charge pump delay time (min) 0 (0...20)

The stop delay for the charge pump can be set here. The charge pump continues to circulate water at the set time after the external boiler has been turned off. Only applies to boilers with very small water volumes in order to avoid overtemperature.

Delay stop ext. boiler 0 (0...240)

If an external boiler is no longer needed, shutting it off can be delayed. This is used to avoid operation times too short (risk of corrosion). The boiler is kept hot according to the set time. Can be set up to 4 hours.

Priority High (Low/High)

The "Low" option means the external boiler is prioritised lower than the immersion heater(s).

The "High" option means the external boiler is prioritised over the immersion heater(s) if both heat sources are defined in the system.

Delay priority low 120 (30...240)

Delay of the heat source which has been given "Low" priority. For instance, if the external boiler has the priority "High", the immersion heater(s) then get(s) the priority "Low" and is/are delayed by the set number of minutes before being permitted to engage and assist in operation. NB: Irrespective of the setting, the immersion heater in the upper tank is used for extra DHW increase.

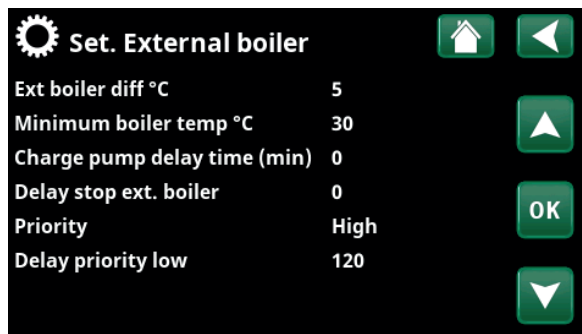

Menu: "Advanced/Settings/External boiler".

12.2.10 Settings, External buffer tank

The buffer tank is charged from the lower tank of the CTC EcoZenith but can be recharged in both the upper and the lower tanks.

This menu bar is displayed if "Buffer tank" has been defined in the "Advanced/Define/External Buffer tank" menu.

dT lower ext °C 7 (3...30)

The temperature difference between the lower tank of the CTC EcoZenith and the lower part of the external buffer tank which controls the conditions for starting the transfer from the CTC EcoZenith to the external buffer tank. This setting applies to charging of solar energy when a heating need is present on the heating circuit.

dT start upper °C 7 (3...30)

The temperature difference between the upper tank of the CTC EcoZenith and the upper part of the external buffer tank which controls the conditions for starting the recharging from the external buffer tank to the upper tank in the CTC EcoZenith.

dT stop upper °C 3 (1...30)

The temperature difference between the upper tank of the CTC EcoZenith and the upper part of the external buffer tank which controls the conditions for stopping the recharging from the external buffer tank to the upper tank in the CTC EcoZenith.

Charge start lower °C 80 (20...90)

Temperature in CTC EcoZenith's lower tank when charging to external buffer tank should start.

dT start lower °C 7 (3...30)

The temperature difference between the lower tank of the CTC EcoZenith and the external buffer tank which controls the conditions for starting the recharging from the external buffer tank to the lower tank in the CTC EcoZenith.

dT stop lower °C 3 (1...30)

The temperature difference between the lower tank of the CTC EcoZenith and the external buffer tank which controls the conditions for stopping the recharging from the external buffer tank to the lower tank in the CTC EcoZenith.

dT setpoint low °C 7 (2...50)

Setting for the number of degrees by which the lower tank of the CTC EcoZenith must exceed its reference value to start transfer to the external buffer tank. This setting applies to charging of solar energy when a heating need is present on the heating circuit.

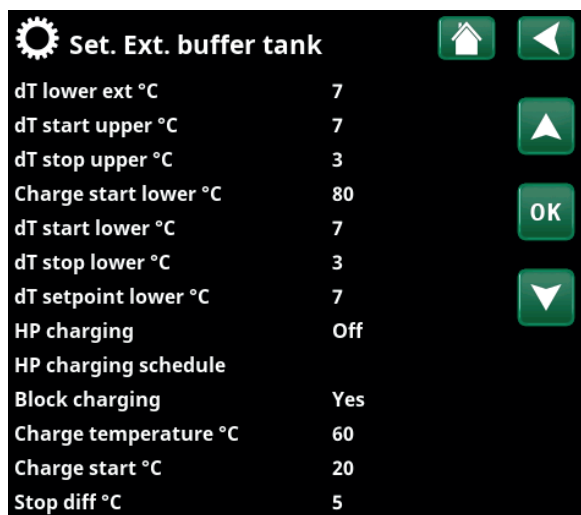

Menu: "Advanced/Settings/External buffer tank".

HP charging Off (Off/20...60)

Setting the setpoint in the lower tank of the CTC EcoZenith when "HP charging" is active by remote control.

The charge to the external buffer tank starts when the temperature in the lower tank of the CTC EcoZenith is higher than the actual demand if also the temperature in the buffer tank is lower than in the lower tank + set temperature difference for charge start.

This menu bar is displayed if both of the criteria below are met:

- a remote control input has been defined for the "HP charging" function.
- A normal position (Normally Open (NO) or Normally Closed (NC)) for the external control signal has been defined in "Def. External buffer tank".

Read more in the "Def. Remote Control" section of the "Advanced/Define" chapter.

HP charging schedule

Charging an external buffer tank with heat from a heat pump is mainly of relevance when there are different tariffs for electricity over a 24 hour period. In such an instance, the buffer tank(s) can be charged when the tariff is low. The lower tank of the CTC EcoZenith will work towards the set temperature during those periods which are scheduled and then transfer heated radiator water to the buffer tank(s), provided that the latter has/have a lower temperature.

This menu bar is displayed if a "Schedule" is defined for the "HP charging" function in the "Advanced/Define/Remote Control" menu.

For more information, refer to:

- chapter "Schedule".
- section "Def. Remote Control" of the "Advanced/Define" chapter for defining the remote control function.

Block charging **Yes (No/Yes)**

Selection "No" means that charging from the lower tank to the external buffer tank starts if the following criteria are met.

- the temperature in the lower tank is higher or equal to the external buffer tank (lower sensor (B42)) + the setting in the menu "dT lower ext °C".
- the temperature in the lower tank is higher or equal to the setpoint + setting in the menu "dT set lower °C".
- the temperature in the lower tank is higher than the external buffer tank (upper sensor B41).

Charging stops when:

- the temperature in the lower tank is lower or equal to the set point + the setting in the "dT stop lower °C" menu.
- the temperature in the lower tank is lower or equal to the value of the lower sensor of the buffer tank + the setting in the "dT start lower" menu.

Selection "Yes" means that if the temperature in the lower tank is higher than the setpoint, there is no overcharge to the buffer tank unless "solar" or "wood" is active.

Charge temperature °C **60**

The temperature in the upper and lower tank when recharging from the external buffer tank to the CTC EcoZenith is stopped.

Charge start °C **20**

Minimum allowed temperature in the external buffer tank to start recharging the CTC EcoZenith even if the criteria concerning temperature difference between the external buffer tank and CTC EcoZenith is met.

Stop diff °C **5**

The number of degrees that the temperature in the external buffer tank is allowed to drop below the specified value in the "Charge start °C" menu bar before recharging to the CTC EcoZenith is cancelled.

12.2.11 Settings, Pool

Pool **Blocked (On/Blocked)**

Whether the pool heating should be "On" or "Blocked" is selected here.

Pool temp °C **22 (20...58)**

The desired pool temperature is set on this menu bar.

Pool diff °C **1.0 (0.2...5.0)**

The permitted difference between the stop and start temperature in the pool is specified here.

Pool priority **Low (Low/High)**

The priority between pool heating and the heating circuit is specified here. If the "Low" setting is selected, the pool is not charged when additional heating is being used.

SmartGrid Blocking °C **Off (Off/-1...-50)**

The setpoint for pool heating is decreased by the value set in this menu when "SmartGrid Blocking" is active.

SmartGrid Low price °C **Off (Off/1...5)**

The setpoint for pool heating is increased by the value set in this menu at "Low price" energy price (when "SmartGrid Low price" is active).

Read more in the "Advanced/Define/Remote control/SmartGrid" menu.

SmartGrid Overcapacity °C **Off (Off/1...5)**

The setpoint for pool heating is increased by the value set in this menu at "Overcapacity" energy price (when "SmartGrid Overcapacity" is active).

Read more in the "Advanced/Define/Remote control/SmartGrid" menu.

Block pool **No (Yes/No)**

This function is used to block external pool heating. This menu bar is displayed if the criteria below are met:

- the pool is connected (defined) to the system
- a remote control input has been defined for the "Block pool" function.
- a normal mode (Normally Open (NO) or Normally Closed (NC)) for the external control signal has been defined.

Read more in the "Def. Remote Control" section of the "Advanced/Define" chapter.

Schedule, Blocking pool

This menu is used to schedule the days of the week when pool heating should be blocked. This schedule is repeated every week. This menu bar is displayed if a schedule has been defined for the "Block Pool" function.

For more information, refer to:

- chapter "Schedule".
- section "Def. Remote Control" of the "Advanced/Define" chapter for defining the remote control function.

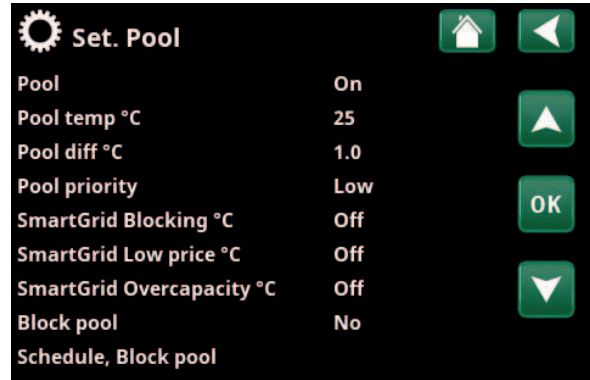

Menu: "Advanced/Settings/Pool".

12.2.12 Settings, Cooling

Room temp. cooling °C 25.0 (10.0...30.0)

Set the desired room temperature for cooling.

Active delay 10 (Off/1...600)

Delay refers to the time (minutes) before the production of cooling is allowed when there is a need for cooling.

Start delay 180 (Off/1...240)

The menu determines the delay time (minutes) from the time the cooling has been blocked (see menu bars "Ext. Block cooling" and "Schedule, Blocking cooling") until the production of cooling is permitted again.

Min flow temp cooling °C 15 (2...30)

The minimum temperature of the cooling flow allowed out to the respective heating circuit.

This setting overrides the value set in the menu bar "Min. primary flow °C".

A 4-digit code (4002) must be entered to set the menu.

Max diff. room temp. cooling °C 5 (0...20)

Specify how many degrees of difference is permitted between the primary flow temperature of the cooling flow and the room temperature.

A 4-digit code (4002) must be entered to set the menu.

SmartGrid Low price °C Off (Off/1...5)

The setpoint for room temperature is decreased by the value set in this menu when "SmartGrid Low price" is active.

The menu bar is displayed if SmartGrid have been defined in the "Advanced/Define/Remote Control" menu.

Read more in the "Remote Control/SmartGrid" section of the "Advanced/Define" chapter.

SmartGrid Overcapacity °C Off (Off/1...5)

The setpoint for room temperature is decreased by the value set in this menu when "SmartGrid Overcapacity" is active.

The menu bar is displayed if SmartGrid have been defined in the "Advanced/Define/Remote Control" menu.

Read more in the "Remote Control/SmartGrid" section of the "Advanced/Define" chapter.

Ext. block cooling No (Yes/No)

Blocking cooling can be remote controlled remotely. For example, the function can be used to turn off cooling with the help of a humidity sensor when there is a risk of condensation.

This menu bar is displayed if the criteria below are met:

- a remote control input has been defined for the "Block cooling" function.
- a normal mode (Normally Open (NO) or Normally Closed (NC)) for the external control signal has been defined on the menu bar "Block cooling ext. config." in the "Advanced/Define/Cooling" menu.

Read more in the "Def. Remote Control" section of the "Advanced/Define" chapter.

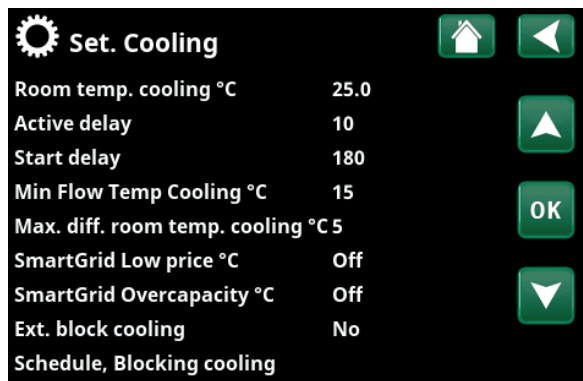

Menu: "Advanced/Settings/Cooling".

• A 4-digit code (4002) must be entered to set the menu "Min. flow temp. cooling" and "Max. diff. room temp. cooling".

When lowering the temperature, any risk of condensation must be taken into account!

If the system is condensation-proofed, significantly lower temperatures are permitted at various points in the system.
 ! WARNING! Build-up of condensation in the house structure can lead to damp and damage from mildew.

In the event of doubt, contact a professional for an assessment.

Schedule, Blocking cooling

This menu is used to schedule the weekday periods during which cooling should be blocked. This schedule is repeated every week.

This menu bar is displayed if a schedule has been defined for the "Block Cooling" function, in the "Advanced/Define/Remote Control" menu.

For more information, refer to:

- chapter "Schedule".
- section "Def. Remote Control" of the "Advanced/Define" chapter for defining the remote control function.

12.2.13 Settings, Communication

Settings can be made here to control the product with a control system.



Menu: "Advanced/Settings/Communication".

12.2.13.1 Settings, Ethernet

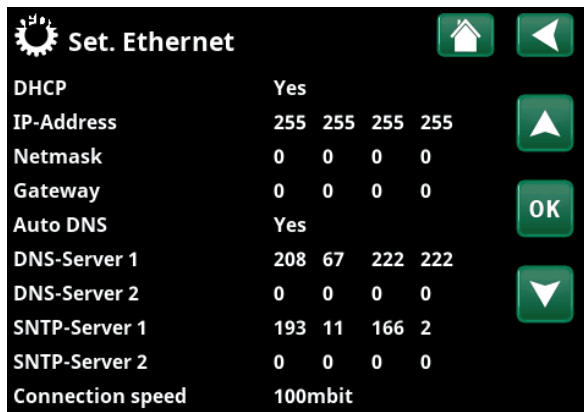

Menu: "Advanced/Settings/Communication/Internet".

DHCP Yes (Yes/No)

"Yes" enables automatic connection to the network.

If "No", custom router settings (IP address, Netmask and Gateway) as well as DNS setting must be made.

Auto DNS Yes (Yes/No)

If "Yes", default DNS server settings are used. If "No", custom DNS settings must be made.

SNTP Server

Option for custom SNTP server settings.

Connection speed 100mbit

Connection speed is specified here.

The factory-set connection speed is 100 mbit/s.

For more information on installing Ethernet cables, see the chapter "Installation, Communication".

12.2.13.2 Settings, BMS

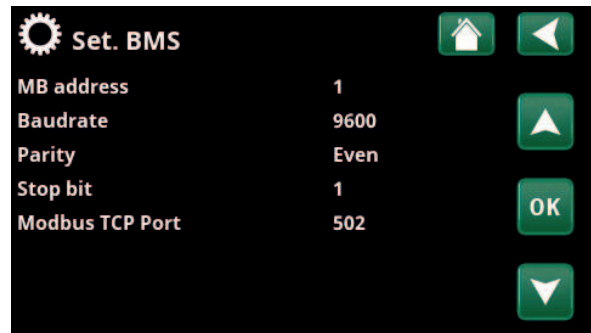

Menu: "Advanced/Settings/Communication/BMS".

MB address 1 (1...255)

Adjustable "1-255".

Baudrate 9600 (9600/19200)

Possible settings: "9600" or "19200".

Parity Even (Even/Odd/None)

Possible settings: "Even", "Odd" or "None".

Stop bit 1 (1/2)

Possible settings: 1 or 2.

Modbus TCP Port 502 (1...32767)

This menu bar is displayed if "Modbus TCP" is defined in the "Ethernet" row in the "Advanced/Define/Remote Control" menu.

12.2.13.3 Settings, myUplink

The menu is used for pairing with the myUplink app.



Menu: "Advanced/Settings/Communication/myUplink".

Request connection string by pressing "Get connection string", confirm with "OK". The menu bar is clickable if the display is connected to the server.

In the app: Scan the QR code or enter values for "Serial" and "Connection string".

Select the menu items "Remove users" and / or "Remove service partners" to disconnect these accounts from the system. Confirm with "OK".

12.2.13.4 Settings, El. prices

Ensure that "myUplink" is selected in the "Def. Communication" menu.

Select "El.prices" in the "Advanced/Settings/Communication" menu to access the "Set. El.prices" menu.



Menu: "Advanced/Settings/Communication/El.prices" where "Advanced/Define/Communication/myUplink: Yes" is selected.

Price control On/Off

Select "On" to show the other menu lines of the "Set. El.prices" display menu.

Regions SE01/SE02/SE03/SE04

Click "OK" on the "Regions" line. If "Regions" are defined for the selected country (see "Advanced/Display/Country" menu), price regions for the country are shown here. Otherwise, the text "No regions available" is displayed. In this example, Swedish price regions are displayed.

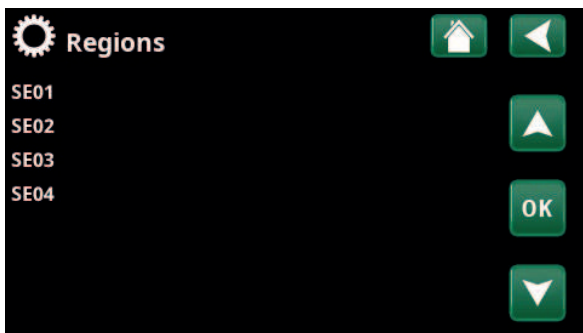

Menu: "Advanced/Settings/Communication/El.prices/Regions" where "Advanced/Define/Communication/myUplink:Yes" is selected

Dynamic Yes/No

"Yes" means that the electricity prices are calculated according to price algorithms that define the price categories ("High", "Medium" and "Low").

Limit value high

Set the limit value above which the electricity price is defined as "High" (in the example, the limit value is SEK 3.50). This can be used together with the dynamic price calculation feature to define a different "High" price range than that determined by the dynamic price calculation feature.

Prices defined as "High" activate the "SmartGrid Blocking" function.

Limit value low

Set the limit value below which the electricity price is defined as "Low" (in the example, the limit value is SEK 1.50). This can be used together with the dynamic price calculation feature to define a different "Low" price range than that determined by the dynamic price calculation feature.

Prices defined as "Low" activate the "SmartGrid Low price" function.

For more information and examples of Smart Electricity Price Control/SmartGrid, see the website www.ctc-heating.com/Products/Download.

Default High/Medium/Low

Select the price category that should apply if prices cannot be retrieved.

Days in calculation 1...10

Select the number of days on which the dynamic calculation of the electricity price will be based. Since the dynamic calculation is based on the average price per day, more days in calculation result in a more stable and reliable value.

Preview data

Click "OK" on the "Preview data" line to display a graph of electricity prices calculated over the selected time interval ("Days in calculation").

The graph can also be displayed by clicking the "El.prices" icon in the "Operation" main menu (see "Operation" section).

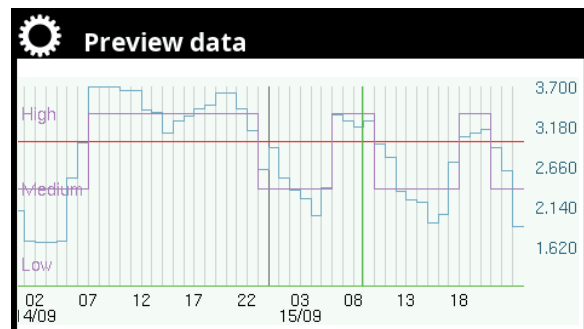

Menu: "Advanced/Settings/Communication/El.prices/Preview data".

Offset % **0 (0...100)**

Enter code "4003" in the "Advanced/Service/Coded settings/Code" menu to display the "Offset %" menu line.

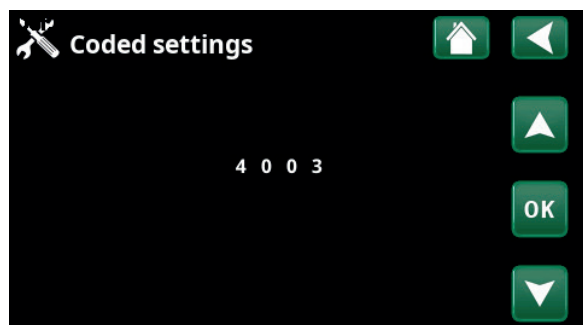

Menu: "Advanced/Service/Coded settings/Code".

"Offset" is the boundary between where "High" price and "Medium" price electricity is determined and is based on the average price for the number of days used in the calculation.

If offset is changed, it will move the curve and the shape will be kept. Use "Inclination" to change the curve.

Width % **50 (0...200)**

Enter code "4003" in the "Advanced/Service/Coded settings/Code" menu to display the "Width %" menu line.

"Width" is the vertical price range where the electricity price is considered "Medium".

12.2.13.5 Settings, Power limitation

Power limitation can be used, for example, if the if the electricity grid operator requires control of the electricity grid load. The function can limit the operating power of the compressor and the immersion heater.

Press "OK" on the "Power limitation" menu bar in the "Advanced/Define/Communication/Power limitation" menu.

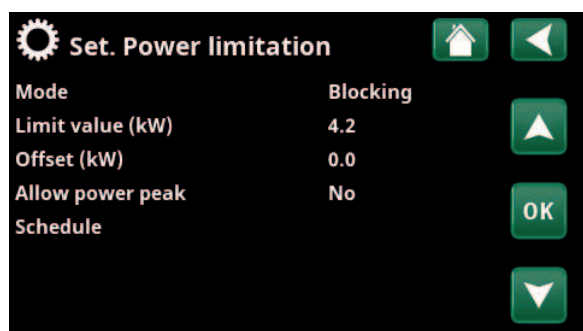

Menu: "Advanced/Settings/Communication/Power limitation".

! CTC EcoLogic L/M and CTC EcoPart i600M must have program version 2025-02-06 or later.

Mode **Blocking (Blocking/Limitation/Off)**

Select "Blocking" if both the heat pump and the additional heat should be blocked from starting.

Select "Limitation" if the operating power of the heating circuit is to be limited. The limit value and the offset must then be set.

Limit value (kW) **4.2 (1.0...100.0)**

Select the operating power value that the heating circuit must not exceed.

Offset (kW) **0.0 (0.0...10.0)**

Deduction from the limit value in addition to the operating power of the compressor and the immersion heater.

Allow power peak **Yes (Yes/No)**

Enter code "4003" in the "Advanced/Service/Coded settings/Code" menu to display the "Allow power peak" menu line.

Select "Yes" if the heat pump is allowed to exceed the set limit value for a short time during start-up.

Only applies to modulating heat pumps.

Schedule **Off/On/Load fact.set.**

In the schedule, the periods is sets for when the power limitation should be active or inactive during the weekdays. For more information, see chapter "Schedule".

12.2.14 Settings, Ventilation

Settings for the CTC EcoVent ventilation product are made here.

For more information, see the "Installation and Maintenance Manual" for CTC EcoVent.

12.2.15 Settings, Current sensor

These menu bars are displayed if "Current Sensor" is defined in the "Advanced/Define/Current Sensor" menu.

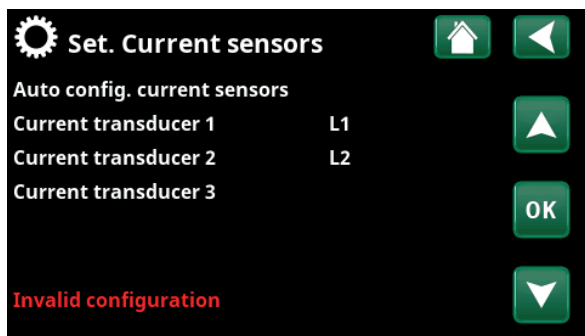

Menu: "Advanced/Settings/Current sensors".

In the menu, specify the phases (L1, L2 and L3) to which the current sensors have been connected.

In the lower left corner of the display, "Invalid configuration" will be displayed until L1, L2, and L3 have been paired with the three current sensors in the menu.

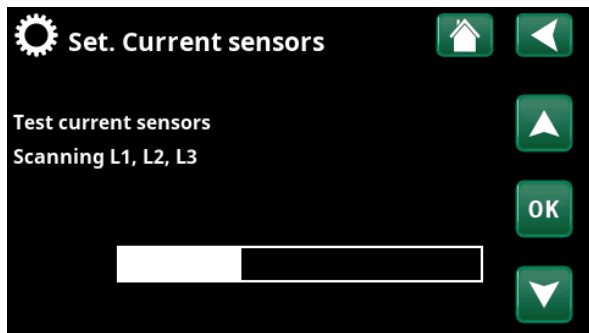

Menu: "Advanced/Settings/Current sensors /Auto config. current sensor".

When activating the "Auto config. current sensors" function, it is important that you have switched off all devices in the house that consume high levels of electricity. Also make sure that the backup thermostat is switched off.

12.2.16 Settings, Round circulation schedule

Round circulation is equipment which an electricity supplier can fit in order to disconnect, for a short period of time, equipment which draws high current. The compressor and electrical output are blocked when round circulation is active.

This menu bar is displayed if a weekly program has been defined for the "Round circulation" function.

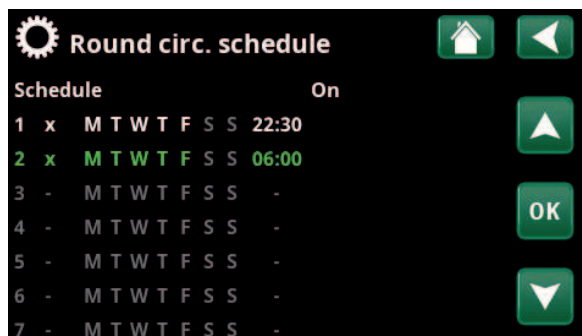

Menu: "Advanced/Settings/Round circulation".

The "Round circulation" function can also be controlled remotely by activating the "Input" defined for the function.

For more information, refer to:

- chapter "Schedule".
- section "Def. Remote Control" of the "Advanced/Define" chapter for defining the remote control function.

12.2.17 Settings, SmartGrid schedule

This menu is used to schedule the weekday periods during which the "SmartGrid" functions should be active. This schedule is repeated every week.

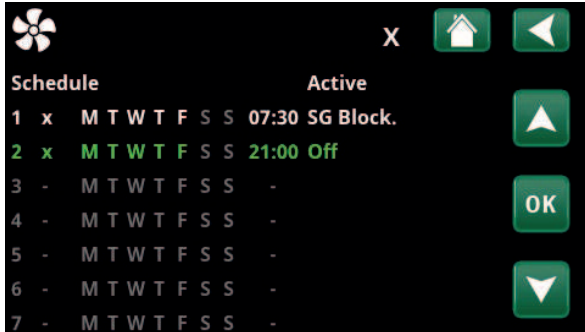

Menu: "Advanced/Settings/SmartGrid schedule".

"SmartGrid" can be used to block a function ("SG Block.") or to achieve a temperature increase during periods when the energy price is low ("SG Low price") or ("SG Overcapacity").

SG Normal mode can be used to easily deviate from any SmartGrid settings for the system on specific days/at specific times.

The "SmartGrid schedule" menu bar is displayed if a schedule has been defined in the "SmartGrid A" row.

For more information, refer to:

- chapter "Schedule".
- chapter "Advanced/Define/Remote Control" for defining SmartGrid.

12.2.18 Save settings

Custom settings can be saved to "Bank" 1-3 and on a USB drive here. The "USB" row is greyed out until the USB drive is installed. The rows show the date and time of saved settings.

Press "OK" to confirm.

12.2.19 Load settings

The saved settings can be recovered.

Press "OK" to confirm.

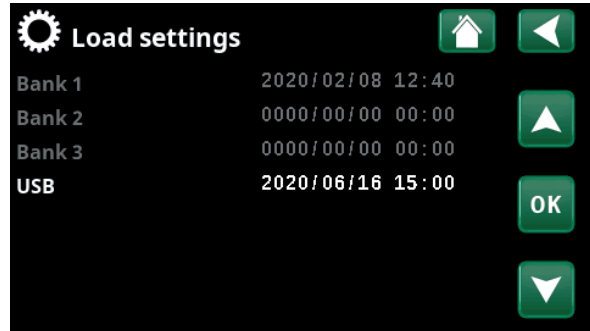

Menu: "Advanced/Settings/Load my settings".

12.2.20 Load Factory settings

The product is supplied with the factory values set. Saved settings in "Bank" 1-3 are deleted when factory settings are restored. The selected language is recovered.

Press "OK" to confirm.

12.3 Define



The "Define" menus specify which components and subsystems the system consists of.

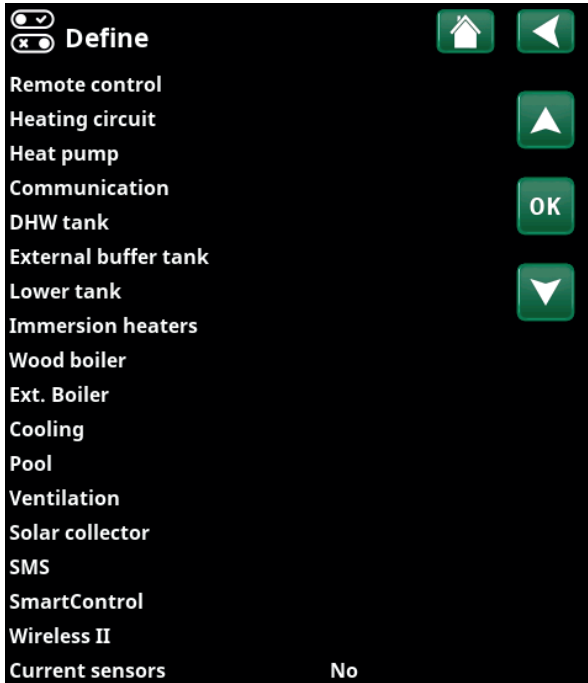

Menu: "Advanced / Define / Remote control".

12.3.1 Define, Remote control

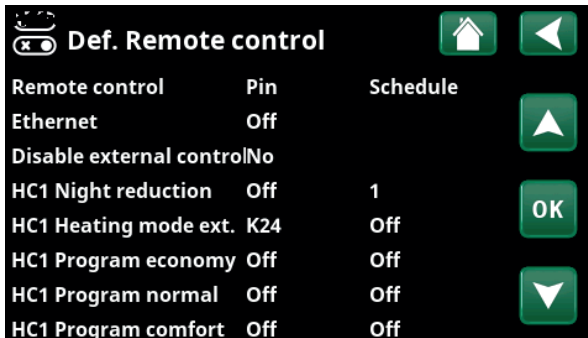

Part of the "Advanced/Define/Remote control" menu.

The "Advanced/Define/Remote control" menu describes all remote control functions, how they are set up and how they are used.

The remote control inputs can be activated by specifying one of the following three modes in the "Input" column:

- a terminal block K22-K23 on the relay board (A2) has power or terminal block K24-K25 is closed. There are two 230 V inputs and two low voltage ports.

Designation	Terminal block position	Connection type
K22	A14 & A25	230V
K23	A24 & A25	230V
K24	G33 & G34	Extra-low voltage (<12V)
K25	G73 & G74	Extra-low voltage (<12V)

The table shows the remote control inputs K22-K25 on the relay board.

- accessories in the CTC SmartControl series, consist of wireless sensors and control units that control signals for temperature, humidity and carbon dioxide levels.
- accessories in the CTC Wireless Room Sensor II series, consist of room unit and a base unit that control signals for temperature.
- BMS control where control signals are transmitted via the BMS interface.

If you want a function to recur during weekdays, you can set when the function should be active/inactive in a schedule.

12.3.1.1 Setting the remote control function

1. Define an "Input"

First, an input must be assigned to the function or functions to be controlled remotely.

In the example, terminal block K24 is selected as the input for the "HC1 Heating mode, ext." function.

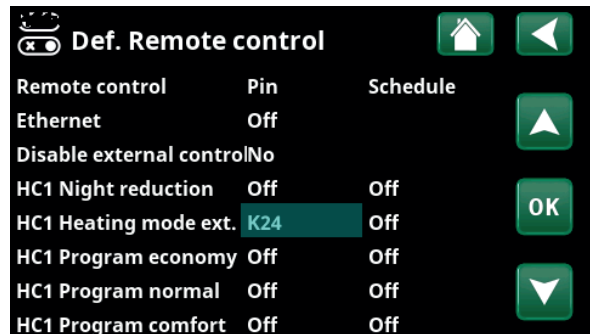

Menu: "Advanced / Define / Remote Control".

2. Configure the function (Normally Open (NO)/Normally Closed (NC))

Define a normal mode for the external control signal; NO or NC. The setting is made for the current heating circuit in the "Advanced/Define/Heating Circuit" menu.

For example, a two-way switch can be connected to the defined input.

If the button when used generates a control signal on the input (circuit closes), the circuit shall be defined as NO. When the circuit closes and the control signal is generated, the heating mode selected in the "HC1 Heating mode, ext. config." row is activated in the settings menu for the heating circuit.

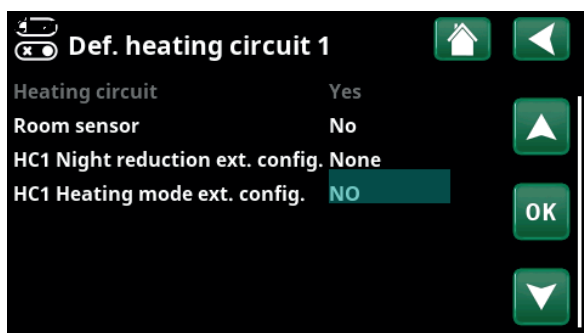

Menu: "Advanced/Define/Heating Circuit/ Heating Circuit 1".

3. Setting the heating mode

In the example, the remote control function "Heating mode, ext." is set to the "Off" position in the "Heating mode, ext." row. This setting is made in the "Advanced/Settings/heating circuit" menu.

In this example, the normal heating mode is active ("On").

When input K24 is closed (the multi-button in the example generates a control signal), the status of the heating mode (normal mode "On" > mode "Off") changes.

Heating remains off until you choose to start the heating (normal mode "On") by opening terminal block K24 (no signal on the terminal block).

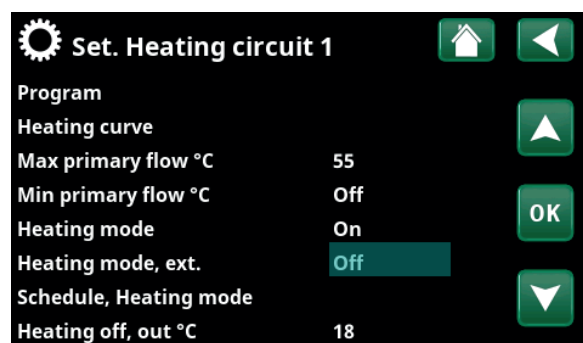

Menu: "Advanced/Settings/Heating Circuit/Heating Circuit 1". Remote control mode "Off" becomes active when terminal block K24 is closed.

Heating mode "On" = Open terminal block.

Heating mode "Off" = Closed terminal block (in this example).

12.3.1.2 Remote control functions

The "Advanced/Define/Remote Control" menu defines Inputs for current remote control functions:

- terminal blocks K22, K23, K24, K25.
- wireless accessories in the SmartControl/Wireless II series (Channel 1A, 1B, 2A, 2B, 3A, 3B and so on up to 7B).
- BMS digital input 0-7. Specify a value 0-255. The value must be set again within half an hour for the setting to persist.

Ethernet (Modbus TCP/Off)

For information about Modbus TCP Port settings, see the "Communication" section in the "Advanced/Settings" chapter.

Disable external control (Yes/No)

Selection "Yes" means disconnecting all external control of the heat pump. Schedule settings are not affected.

HC1- Night reduction*

The "Night Reduction" function can be used to, for example, lower the indoor temperature during the night or during working hours.

In the "Advanced/Define/Remote Control" menu:

- specify an "Input" for the remote control function.

In the "Advanced/Define/Heating Circuit" menu:

- configure the normal mode for the external control signal (Normally Open (NO)/Normally Closed (NC)).

The schedule can be set in the "Heating/Cooling" menu.

For more information, see the "Night Reduction Temperature" section in the "Heating/Cooling" chapter.

HC1- Heating mode, ext.*

Switching between heating season and summer season can take place at a specific outdoor temperature (Auto) or heating can be either always "On" or "Off".

In the "Advanced/Define/Remote Control" menu:

- specify an "Input" for the remote control function.

In the "Advanced/Define/Heating Circuit" menu:

- configure the normal mode for the external control signal (Normally Open (NO)/Normally Closed (NC)).

In the "Advanced/Settings/Heating Circuit" menu:

- set "Remote Control Mode" ("On", "Off" or "Auto") in the "Heating mode, ext." row.
- Access function scheduling from the "Schedule, Heating mode" row.

For more information, see the "Heating Circuit" section in the "Advanced/Settings" chapter.

Also see the "House heating settings" chapter.

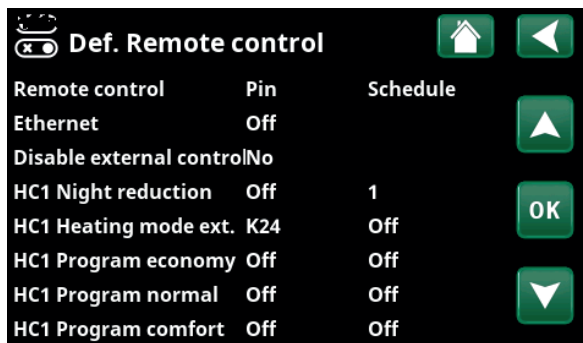

Part of the "Advanced/Define/Remote Control" menu. "Input" and "Schedule" are defined here.

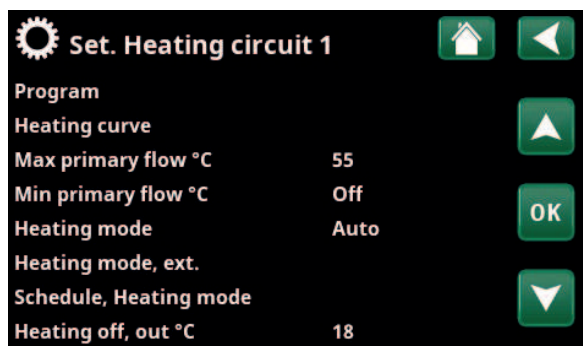

Menu: "Advanced/Settings/Heating Circuit". The remote control mode for the heating circuit is set on menu bar "Heating mode, ext.". Access the schedule from the menu bar "Schedule, Heating mode".

*CTC EcoZenith i555 can control up to 3 CTC heat pumps and 3 heating circuits simultaneously.

HC1- Program economy/normal/comfort/custom ext. config.

The program functions "Economy", "Normal" "Comfort" and "Custom" can be used to change the indoor temperature for a certain period.

In the "Advanced/Define/Remote Control" menu:

- specify an "Input" for the remote control function.

In the "Advanced/Define/Heating circuit":

- configure the normal mode for the external control signal (Normally Open (NO)/Normally Closed (NC))

Setting the schedule is done from the "Heating/Cooling/Program" menu.

For more information, see section "Heating program" in chapter "Heating/Cooling".

Drying period

Floor drying function for newly built properties.

In the "Advanced/Define/Remote Control" menu:

- specify an "Schedule" (Off/1...20) for the remote control function.

For more information and settings, see section "Drying period" in chapter "Settings/Heating circuit".

Extra DHW

Upon activation, production of extra DHW begins. When activation stops, extra DHW is produced for a run-on time of 30 min. The "Stop temperature" for extra DHW is set in the "Advanced/Settings /DHW Tank/DHW program" menu.

In the "Advanced/Define/Remote Control" menu:

- specify an "Input" for the remote control function.

In the "Advanced/Define/DHW Tank" menu:

- configure the normal mode for the external control signal (Normally Open (NO)/Normally Closed (NC)).

Setting extra DHW production to start immediately can also be done in the "DHW" menu. The schedule for extra DHW can also be set in this menu.

For more information, see the "Extra DHW" section in the "DHW" chapter.

HC1 Night reduction ext. config.	None
HC1 Heating mode ext. config.	None
Program economy ext. config.	None
Program normal ext. config.	None
Program comfort ext. config.	None
Program custom ext. config.	None

Menu "Advanced/Define/Heating circuit". In the menu bars "Program economy / normal / comfort / custom ..." the normal mode is indicated on the external control signal ("Normally Open (NO)" or "Normally Closed (NC)").

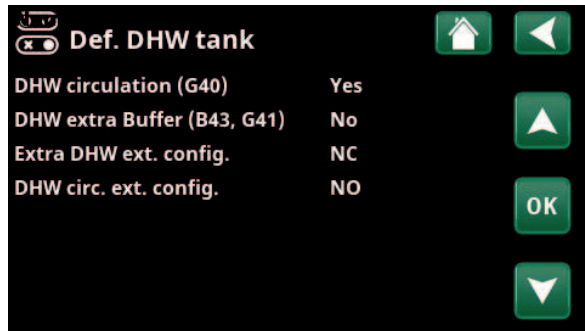

Menu: "Advanced/Define/DHW Tank". On menu bar "Extra DHW ext. config.", the normal mode is specified for the external control signal ("Normally Open (NO)" or "Normally Closed (NC)").

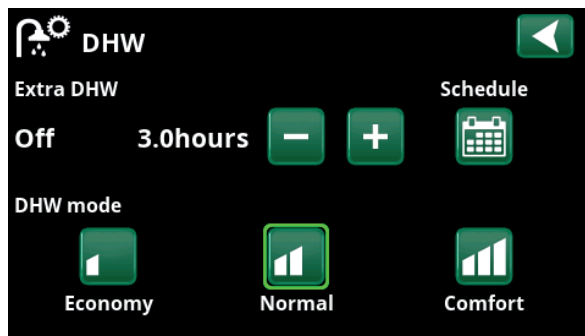

Setting the "Extra DHW" in the "DHW" menu.

Block Cooling

In the "Advanced/Define/Remote Control" menu:

- specify an "Input" for the remote control function.

In the "Advanced/Define/Cooling" menu:

- configure the normal mode for the external control signal (Normally Open (NO)/Normally Closed (NC)).

In the "Advanced/Settings/Cooling" menu:

- set the remote control mode ("Yes") in the "Ext. block cooling" row.
- Access function scheduling from the "Schedule, Blocking cooling" row.

For more information, see the "Cooling" section in the "Advanced/Settings" chapter.

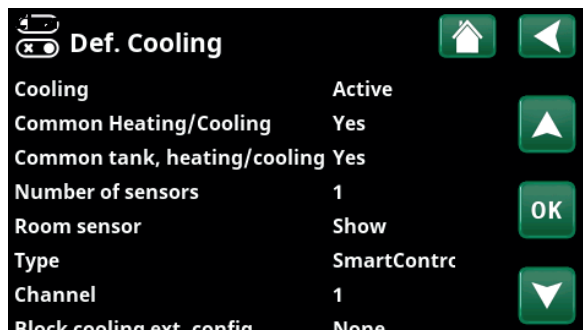

Menu "Advanced / Define / Cooling".
On menu bar "Block cooling ext. config.", the normal mode is specified for the external control signal ("Normally Open (NO)" or "Normally Closed (NC)").

Block Pool

This function is used to block pool heating.

In the "Advanced/Define/Remote Control" menu:

- specify an "Input" for the remote control function.

In the "Advanced/Define/Pool" menu:

- configure the normal mode for the external control signal (Normally Open (NO)/Normally Closed (NC)).

In the "Advanced/Settings/Pool" menu:

- set the "remote control mode" ("On") in the "Blocking Pool" row.
- Access function scheduling from the "Schedule, Block pool" row.

For more information, see the "Pool" section in the "Advanced/Settings" chapter.

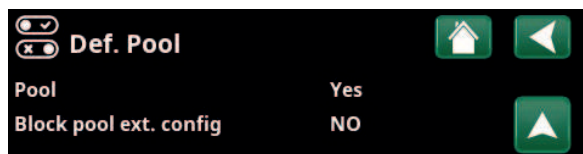

Menu: "Advanced/Define/ Pool".
A mode for the external control signal ("Normally Open (NO)" or "Normally Closed (NC)") is defined in the "Advanced/Define/Pool" menu.

Tariff EL

This function is used to block the immersion heater during periods when the electricity rate is higher.

In the "Advanced/Define/Remote Control" menu:

- specify an "Input" for the remote control function.

In the "Advanced/Settings/Immersion heaters" menu:

- set "remote control mode" ("Yes") in the "Tariff EL" row.
- Access function scheduling from the "Tariff EL schedule" row.

For more information, see the "Immersion heaters/Tariff EL" section in the "Advanced/Settings" chapter.

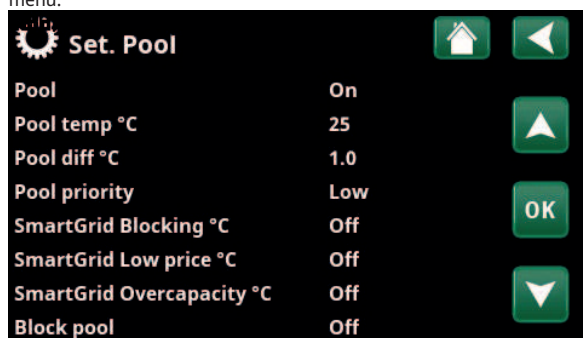

Menu: "Advanced/Settings/Pool".
Activate this function via an external control signal or a schedule.

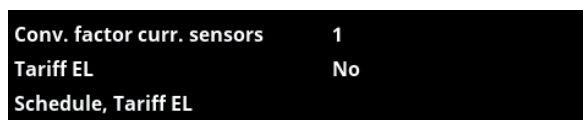

Menu: "Advanced/Settings/Immersion heaters".
Setting "Tariff EL" via an external control signal or a schedule.

Round circulation

Round circulation is an equipment that the electricity supplier can mount, for a shorter time, to disconnect power-intensive equipment. Compressor and electric power are blocked when round circulation is active.

In the "Advanced/Define/Remote Control" menu:

- specify an "Input" for the remote control function.

In the "Advanced/Settings" menu:

- Access function scheduling from the "Round circ. schedule" row.

For more information, see the "Round circulation" section in the "Advanced/Settings" chapter.

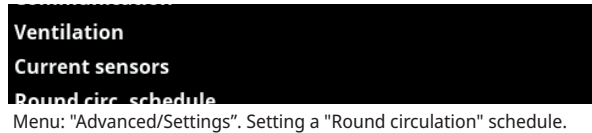

DHW circulation

The function allows DHW to circulate in the pipes between the taps and the DHW tank, ensuring that the DHW is hot when the taps are opened.

In the "Advanced/Define/Remote Control" menu:

- specify an "Input" for the remote control function.

In the "Advanced/Define/DHW Tank" menu:

- configure the normal mode for the external control signal (Normally Open (NO)/Normally Closed (NC)) in the "DHW circ. ext. config." row.

In the "Advanced/Settings/DHW Tank" menu:

- Access function scheduling from the "Schedule, DHW circulation" row.

For more information, see the "DHW Tank" section in the "Advanced/Settings" chapter.



Lower tank

The heat pump is producing heat for the heating circuit in the lower tank.

In the "Advanced/Define/Remote Control" menu:

- specify an "Input" for the remote control function.

In the "Advanced/Define/Lower Tank" menu:

- configure the normal mode for the external control signal (Normally Open (NO)/Normally Closed (NC)) in the "Lower tank ext. config." row.

Access function scheduling in the "Advanced/Settings/Lower Tank" menu.

For more information, see the "Lower Tank" section in the "Advanced/Settings" chapter.

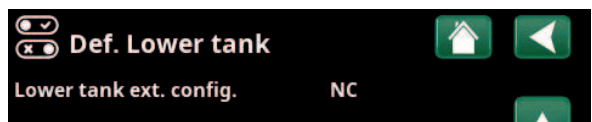
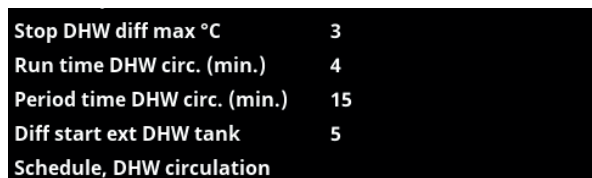

HP charging

HP charging refers to heat pump charging of the external buffer tank.

In the "Advanced/Define/Remote Control" menu:

- specify an "Input" for the remote control function.

In the "Advanced/Define/External buffer tank" menu:

- configure the normal mode for the external control signal (Normally Open (NO)/Normally Closed (NC)) in the "HP charging ext. config." row.

In the "Advanced/Settings/External buffer tank" menu:

- set "remote control mode" ("On") in the "HP charging" row.
- Access function scheduling from the "HP charging schedule" row.

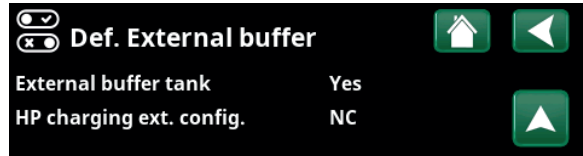

Menu: "Advanced/Define/External Buffer Tank". Define a mode (Normally Open (NO) or Normally Closed (NC)) for the external control signal.

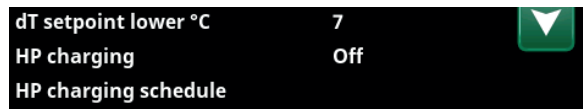

Menu: "Advanced/Settings/External Buffer Tank".

Flow/level switch

The flow/level switch produces an alarm on the heat pump.

In the "Advanced/Define/Remote Control" menu:

- specify an "Input" for the remote control function.

In the "Advanced/Define/Heat Pump" menu:

- configure the normal mode for the external control signal (Normally Open (NO)/Normally Closed (NC)) in the "Flow/level switch" row.

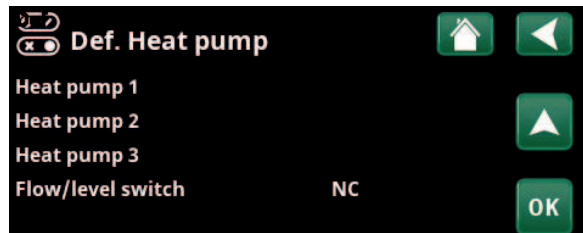

Menu: "Advanced/Define/Heat Pump".

SmartGrid A / SmartGrid B

In the "Advanced/Define/Remote Control" menu:

- specify an "Input" for the remote control function.

There are three SmartGrid functions:

- SmartGrid Low Price
- SmartGrid Overcapacity
- SmartGrid Blocking

Example of "SmartGrid Low Price" for pool heating

In this example, "SmartGrid A" and "SmartGrid B" have been assigned terminal blocks K22 and K23, respectively. In addition, SmartGrid A is assigned "Schedule #1".

According to the settings in the "Set. Pool" menu, the pool setpoint will be increased by 5 °C when the electricity price is low (when the "SmartGrid Low price" function is active) and the setpoint will be decreased by 10°C* when the electricity price is high (when the "SmartGrid Blocking" function is active).

SmartGrid functions can be set (depending on system configuration/heat pump model) for Heating circuit including Heating program economy/comfort/custom, Heat pumps, Additional heating, Cooling, Pool, DHW tank, Buffer tank and Upper* and Lower* tank.

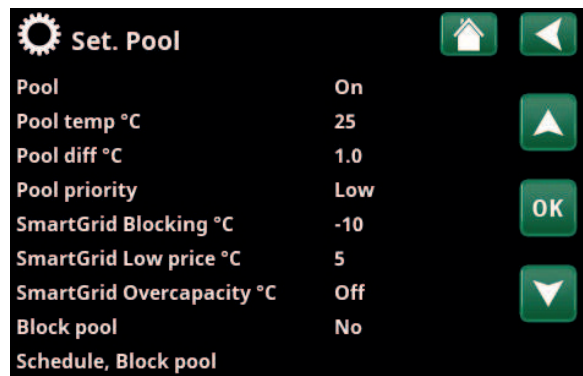

Menu: "Advanced/Settings/Pool". The pool temperature is increased by 5 °C when the SmartGrid Low Price function is activated.

Heating circuit 1-*

- SmartGrid Blocking (Off/On)
- SmartGrid Low price °C (Off/1...5 °C)
- SmartGrid Overcapacity °C (Off/1...5 °C)

Heating program

-Comfort:

- SmartGrid Low price °C (Off/On)
- SmartGrid Overcapacity °C (Off/On)

-Custom:

- SmartGrid Low price °C (Off/On)
- SmartGrid Overcapacity °C (Off/On)
- SmartGrid Blocking (Off/On)

-Economy:

- SmartGrid Blocking (Off/On)

Heat pump*

- SmartGrid Blocking HP (Yes/No)

Additional Heat/Immersion heater

- SmartGrid Blocking EL (Yes/No)
- SmartGrid Blocking Mixing valve (Yes/No)

Cooling

- SmartGrid Low Price °C (Off/1...5 °C)
- SmartGrid Overcapacity °C (Off/1...5 °C)

Pool

- SmartGrid Blocking °C (Off/-1...-50 °C)
- SmartGrid Low Price °C (Off/1...50 °C)
- SmartGrid Overcapacity °C (Off/1...50 °C)

DHW tank/Lower tank/Upper tank

- SmartGrid Blocking °C (Off/-1...-50 °C)
- SmartGrid Low Price °C (Off/1...30 °C)
- SmartGrid Overcapacity °C (Off/1...30 °C)

Buffer tank

- SmartGrid Low Price °C (Off/1...30 °C)
- SmartGrid Overcapacity °C (Off/1...30 °C)

SmartGrid functions are enabled by activating the SmartGrid inputs in different ways according to the table on the right.

To enable the SmartGrid function "SG Low Price" as shown in the example, terminal block K23 must have power while terminal block K22 should remain unchanged.

The pool temperature increase that will apply when "SG Low Price" is activated is set in the "Pool Settings" menu, as shown in the example.

Alternatively, a schedule can be set up for periodic SmartGrid activation. See the "Schedule" chapter for more information.

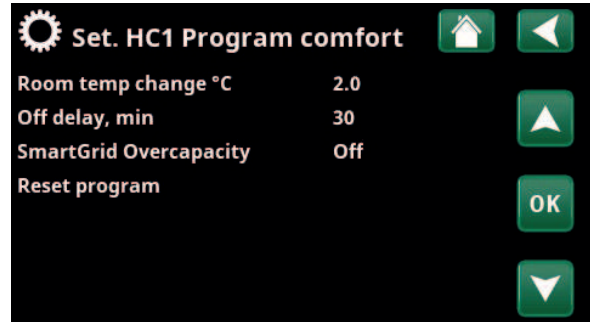

Menu "Advanced/Settings/Heating Circuit/Heating Circuit 1/Program/Comfort".

K22 (SG A)	K23 (SG B)	Function
Open	Open	Normal
Open	Closed	Low price
Closed	Closed	Overcapacity
Closed	Open	Blocking

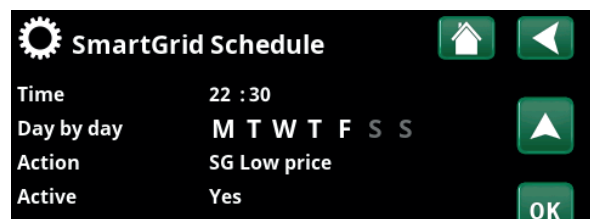

The schedule is set to start at 22:30, weekdays.

*CTC EcoZenith i555 can control up to 3 CTC heat pumps and 3 heating circuits simultaneously.

**Vent. Reduced/Vent. Normal/Vent. Boost/
Vent. Custom/Vent. Away**

When there is a signal in the respective ventilation function's remote control input, the selected ventilation mode will start and be active for half an hour.

In the "Advanced/Define/Remote Control" menu:

- specify and "Input" for current ventilation functions.

Click the Ventilation symbol in the start menu to access the "Ventilation" menu, where ventilation settings can be made. The schedule can also be accessed from there. However, a schedule cannot be specified for the "Vent. Away" ventilation mode.

For more information, please see the CTC EcoVent ventilation product manual.

Tariff HP (1-*)

This function is used to block the heat pump during periods when the electricity rate is higher.

In the "Advanced/Define/Remote Control" menu:

- specify an "Input" for the remote control function.

In the "Advanced/Define/Heat Pump" menu:

- configure the normal mode for the external control signal (Normally Open (NO)/Normally Closed (NC)) in the "Tariff HP ext. config." row.

In the "Advanced/Settings/Heat Pump/Heat Pump (1-)*" menu:

- set "Tariff HP" ("On").

For more information, see the "Heating Pump" section in the "Advanced/Settings" chapter.

HP Noise Reduction (1-*)

This function can be used to reduce compressor speed in order to reduce the noise level.

In the "Advanced/Define/Remote Control" menu:

- specify an "Input" for the remote control function.

In the "Advanced/Define/Heat Pump" menu:

- configure the normal mode for the external control signal (Normally Open (NO)/Normally Closed (NC)) in the "Noise reduction ext. config." row.

In the "Advanced/Settings/Heat Pump/Heat Pump 1*" menu:

- in the "Ext.Noise reduction RPS" row, set the compressor speed value applicable for remote control.

For more information, see the "Heating Pump" section in the "Advanced/Settings" chapter.

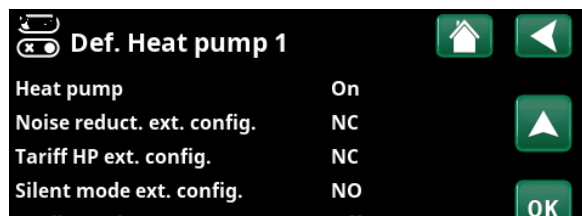

Menu: "Advanced/Define/Heat Pump".
A mode for the external control signal ("Normally Open (NO)" or "Normally Closed (NC)") is defined for "Tariff HP ext. config."

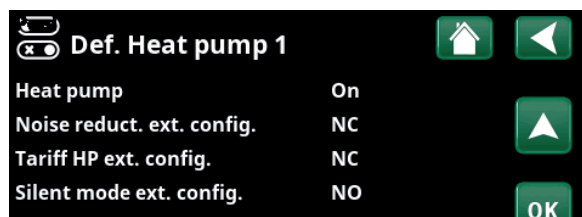

Menu: "Advanced/Define/Heat Pump".
A mode for the external control signal ("Normally Open (NO)" or "Normally Closed (NC)") is defined for "Noise reduction ext. config."

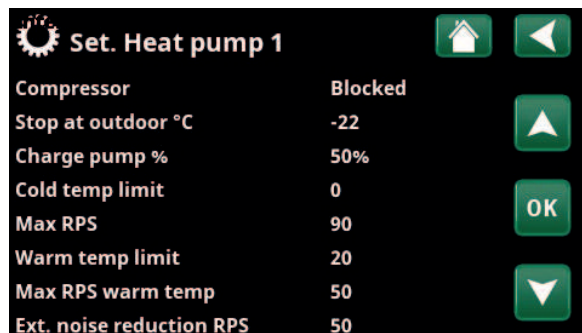

Menu: "Advanced/Settings/Heat Pump /Heat Pump 1-".
Set the compressor speed value applicable for remote control in the "Ext.Noise reduction RPS" row.

*CTC EcoZenith i555 can control up to 3 CTC heat pumps and 3 heating circuits simultaneously.

HP Silent Mode (1-*)

This function can be used to reduce compressor speed and fan speed in order to reduce the noise level.

*Only applies to certain air-to-water heat pumps

In the "Advanced/Define/Remote Control" menu:

- specify an "Input" for the remote control function.

In the "Advanced/Define/Heat Pump" menu:

- configure the normal mode for the external control signal (Normally Open (NO)/Normally Closed (NC)) in the "Silent mode ext. config." row.

For more information, see the "Heating Pump" section in the "Advanced/Settings" chapter.

Power limitation

Power limitation can be used, for example, if the if the electricity grid operator requires control of the electricity grid load. The function can limit the operating power of the compressor and the immersion heater.

In the "Advanced/Define/Remote Control" menu:

- specify an "Input" for the remote control function.

In the "Advanced/Define/Communication" menu:

- configure the normal mode for the external control signal (Normally Open (NO)/Normally Closed (NC)) in the "Power limitation ext. config." row.

In the "Advanced/Settings/Power limitation" menu:

- Access function scheduling from the "Schedule" row.

For more information, see the "Power limitation" section in the "Advanced/Settings" chapter.

**CTC EcoZenith i555 can control up to 3 CTC heat pumps and 3 heating circuits simultaneously.*

12.3.2 Define, Heating circuit

Heating circuit 1-* **Yes (Yes/No)**

Heating circuit 1 (HC1) is predefined.

The rows under Heating Circuit 1 show the other definable heating circuits (HC 2-3 in the example).

The heating circuits shown depend, among other things, on which heating circuits are part of the defined System Type (1-6).

Room sensor **Yes (Yes/No/Show)**

Selection "Yes" means that room sensors should be connected to the heating circuit.

If "Show" is selected, the room temperature is displayed but the room sensor is not used for control.

Type **Cable/Wireless/Wireless II/SmartControl**

Select whether the room sensor for the heating circuit has a wired (via cable) or wireless connection.

- **Cable**
Wired room sensor.
- **Wireless**
Select "Wireless" to connect CTC's wireless room sensors to the heating circuit. Refer to the "CTC Wireless Room Sensor" manual for information on how to connect these sensors.
- **Wireless II**
Select "Wireless II" to connect CTC's wireless room sensor II to the heating circuit. See the "CTC Wireless Room Sensor II" manual for information on how to connect these sensors.
- **SmartControl**
CTC SmartControl is a separate series of wireless accessories. If "SmartControl" is selected, the connection channel must be selected in the row below. CTC SmartControl accessories are connected to the system via the "Advanced/ Define/SmartControl" menu. Refer to the separate CTC SmartControl Accessories manual.

HC1- Night reduction ext. config. **None (None/NO/NC)**

This menu defines the Normally Open (NO) or Normally Closed (NC) mode for the external control signal when remotely controlling the function. For examples of how to set the normal mode, refer to the "Advanced/Define/Remote Control" chapter.

HC1- Heating mode ext. config. **None (None/NO/NC)**

This menu defines the Normally Open (NO) or Normally Closed (NC) mode for the external control signal when remotely controlling the function. For examples of how to set the normal mode, refer to the "Advanced/Define/Remote Control" chapter.

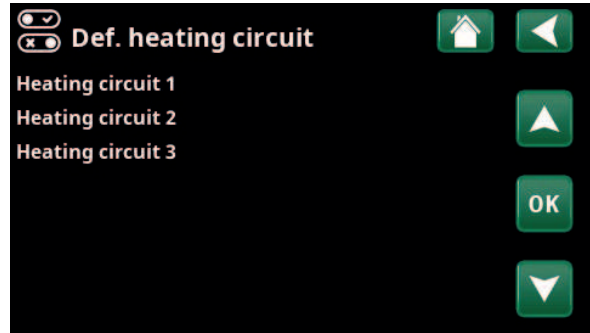

Menu: "Advanced/Define/Heating Circuit". Select a heating circuit and press "OK" to access the settings.

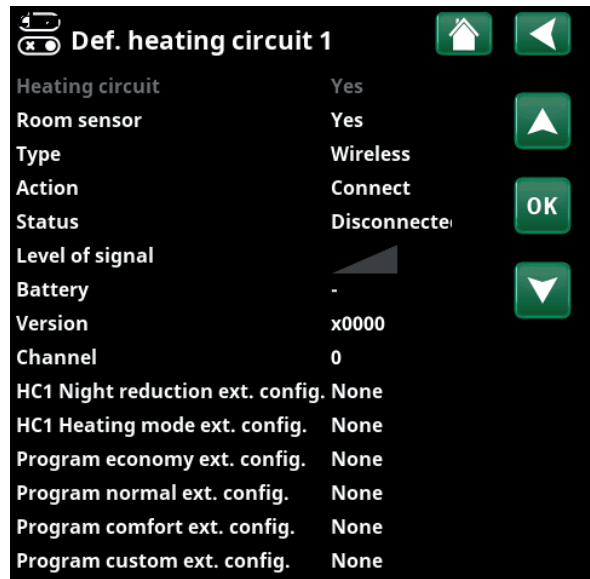

Menu: "Advanced/Define/Heating Circuit/Heating Circuit 1". Wireless room sensor II selected.

Program ** ext. config. **None (None/NO/NC) **economy/normal/comfort/custom**

This menu defines the Normally Open (NO) or Normally Closed (NC) mode for the external control signal when remotely controlling the function. For examples of how to set the normal mode, refer to the "Advanced/Define/Remote Control" chapter.

*CTC EcoZenith i555 can control up to 3 CTC heat pumps and 3 heating circuits simultaneously.

12.3.3 Define, Heat pump

Heat pump 1-* **On/Off**

Select a heat pump to be connected to the system and press "OK" to access the settings.

Flow/level switch **NC (None/NC/NO)**

This menu bar is displayed if an "Input" for remote control is defined for the "Flow/level switch" function in the "Advanced/Define/Define Remote Control" menu.

12.3.3.1 Define, Heat pump 1

Heat pump **On/Off**

Select "On" to connect the heat pump to the system.

Noise reduct. ext. config. **NC (None/NC/NO)**

This menu bar is displayed if an "Input" for remote control is defined for the "HP Noise Reduction" function in the "Advanced/Define/Remote Control" menu.

Tariff HP ext. config. **NC (None/NC/NO)**

This menu bar is displayed if an "Input" for remote control is defined for the "HP Tariff" function in the "Advanced/Define/Remote Control" menu.

Silent mode ext. config.** **NO (None/NC/NO)**

This menu bar is displayed if an "Input" for remote control is defined for the "Silent Mode" function in the "Advanced/Define/Remote Control" menu.

Cooling valve **Off (Off/On)**

Select whether the cooling valve is to be "On" or "Off".

12.3.4 Define, Communication

myUplink **No (Yes/No)**

Select "Yes" to connect to the heat pump from the myUplink app

Web **No (Yes/No)**

Select "Yes" to connect to the local web server. Internet router and firewall required.

El.prices **myUplink/myUplink ext./BMS/No**

Select "myUplink" to connect the heat pump to the myUplink mobile app for electricity price control.

Select "myUplink ext." to connect via myUplink to an external price control app. This option is not available at the moment.

Select "BMS" to connect via property management.

Power limitation ext. config. **None (None/NC/NO)**

This menu bar is displayed if an "Input" for remote control is defined for the "Power limitation" function in the "Advanced/Define/Remote Control" menu.

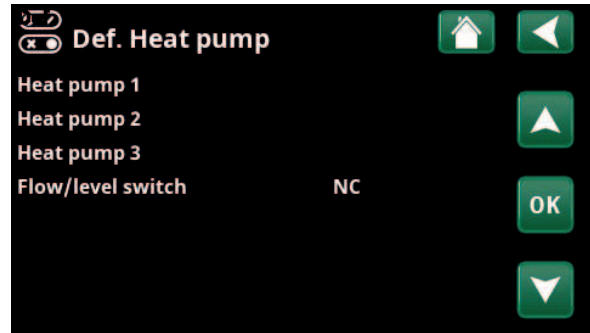

Menu: "Advanced/Define/Heat Pump". Select a heat pump and press "OK" to access the settings.

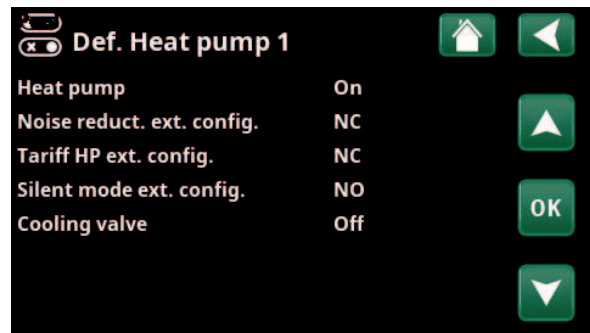

Menu: "Advanced/Define/Heat Pump/Heat Pump 1".

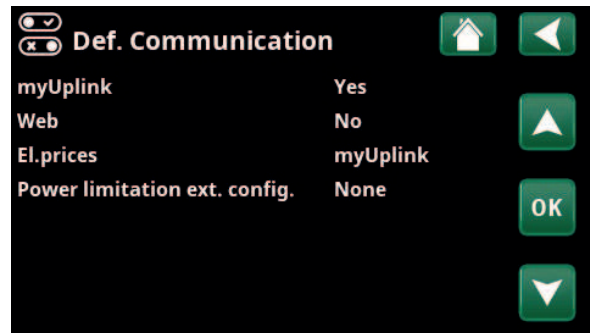

Menu: "Advanced/Define/Communication".

i For more information, see the "Installation Communication" chapter of this manual.

*CTC EcoZenith i555 can control up to 3 CTC heat pumps and 3 heating circuits simultaneously.

*Only applies to certain air-to-water heat pumps.

12.4 Cascade connection

12.4.1 Define number of heat pumps

Define the heat pumps: "Advanced/Define/Heat pump".

Set the heat pumps contained in the system to position "On".

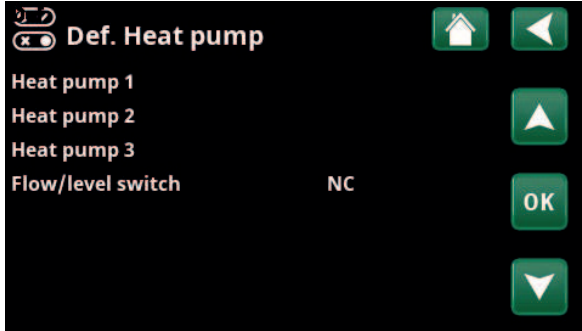

Example of a system with 3 heat pumps.

- Go to "Advanced/Service/Set Address".

Select "Current address", press OK. Press the up/down arrow until the current heat pump appears (HP1). Press OK.

Select "New address", press OK. Press the up/down arrow until the current address for the heat pump appears (HP2). Press OK.

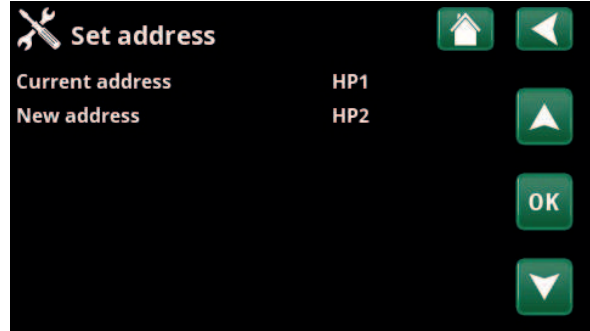

12.4.2 Numbering control system as HP2

- System disconnected from power.

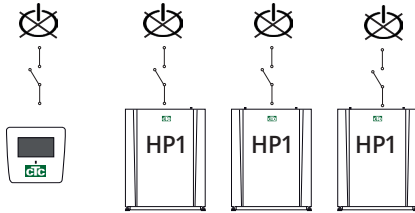

- Energise the control as well as the heat pump to be numbered as Heat Pump 2 (HP2).

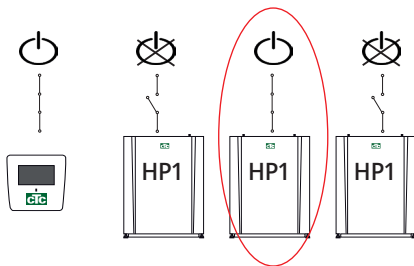

- Wait for about 2 minutes.

- The heat pump is now numbered (HP2).

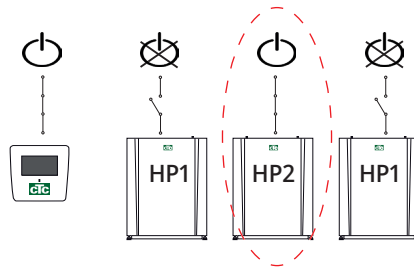

When you press OK, (HP1 and HP2)* disappears and the row "Current address/New Address" will go dark.

**In this example, we have assumed that the heat pump is called HP1, which is the factory default. If the heat pump has already been renumbered, then select this number instead.*

- Number the next heat pump:

Energise the next heat pump, which will be numbered heat pump 3 (HP3).

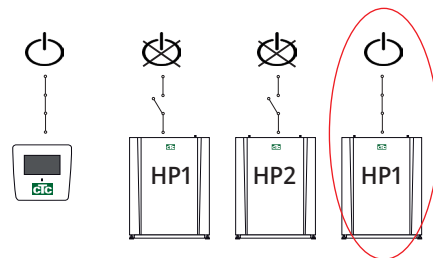

- Wait for about 2 minutes.

- Go to "Service/Set Address".

Select "Current address", press OK. Press the up/down arrow until the current heat pump appears (HP1). Press OK.

Select "New address", press OK. Press the up/down arrow until the current address for the heat pump appears (HP3). Press OK.

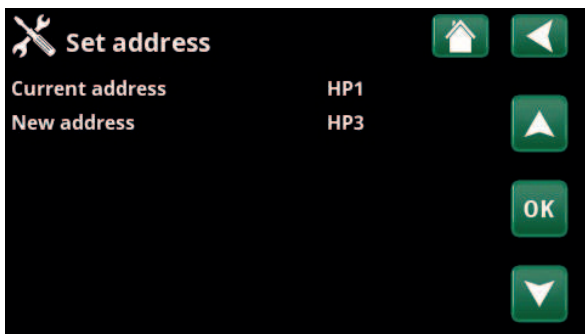

- The heat pump is now numbered (HP3).

When you press OK, (HP1 and HP3)* disappears and the row "Current address/New Address" will go dark.

**In this example, we have assumed that the heat pump is called HP1, which is the factory default. If the heat pump has already been renumbered, then select this number instead.*

- Redo the procedure according to the number of heat pumps to be numbered.

When all heat pumps are numbered and energised, they should be displayed when you press the heat pump symbol in the menu "Operation data". If any heat pump does not appear in the menu (communication with the heat pump fails) It may be because it has not been numbered as described above.

If you do not know the name of the heat pump, you can reset the numbering by using the "Select/Rename Heat Pump" menu (refer to points 9 and 10 above) to indicate all possible names of the heat pump, i.e. you select and confirm HP1 and then HP2 up to HP10 to ensure that the correct name is given.

Finally test in the menu "Advanced/Service/Function test/Heat pump" that the respective heat pump starts.

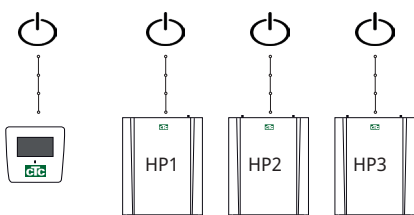

12.4.3 Worth knowing when addressing

Error set Address

The heat pump could not be found and numbered.

The heat pump was not what it was supposed to be called.

No communication with the heat pump.

Check that the heat pump is energised.

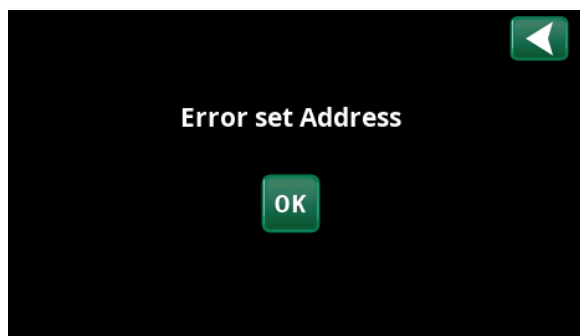

If the setting of the address fails, the latest heat pump addresses remain. In this example HP1 and HP2.

Make sure the heat pump is energised.

Try again with a new current address.

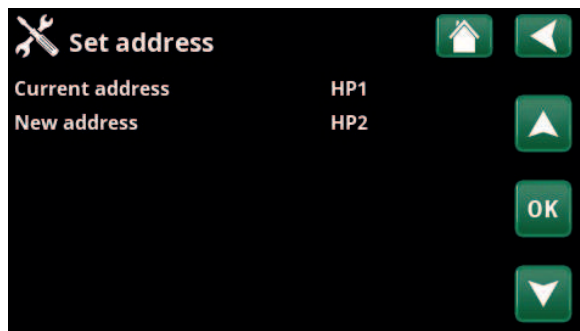

12.4.4 Define, DHW tank

DHW circulation (G40) Yes (Yes/No)

Specify whether the circulation pump (G40) is connected to the DHW system.

DHW extra Buffer (B43, G41) No (Yes/No)

Specify whether the circulation pump (G41) and external DHW tank sensor (B43) are connected to the DHW system.

Extra DHW ext. config. NC (None/NC/NO)

This menu defines the Normally Open (NO) or Normally Closed (NC) mode for the external control signal when remotely controlling the function.

For examples of normal mode settings, refer to the "Def. Remote Control" section of the "Advanced/Define" chapter.

DHW circ. ext. config. NO (None/NC/NO)

This menu bar is displayed if "DHW circulation (G40)" is defined as above.

This menu defines the Normally Open (NO) or Normally Closed (NC) mode for the external control signal when remotely controlling the function.

For examples of normal mode settings, refer to the "Def. Remote Control" section of the "Advanced/Define" chapter.

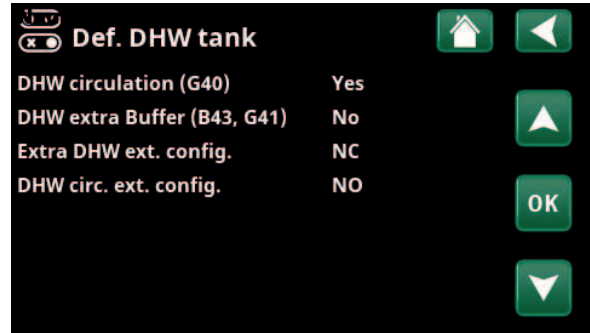

Menu: "Advanced/Define/DHW Tank".

12.4.5 Define, External buffer tank

External buffer tank Yes (No/Yes)

Specify whether an external buffer tank is connected to the system.

HP charging ext. config. NC (None/NC/NO)

This menu defines the Normally Open (NO) or Normally Closed (NC) mode for the external control signal when remotely controlling HP charging of the buffer tank.

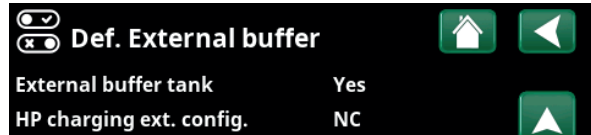

Menu: "Advanced/Define/External buffer tank".

12.4.6 Define, Lower tank

Lower tank ext. config. NC (None/NC/NO)

This menu defines the Normally Open (NO) or Normally Closed (NC) mode for the external control signal when remotely controlling charging of the lower tank.

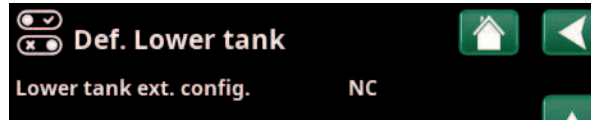

Menu: "Advanced/Define/Lower tank".

12.4.7 Define, Immersion heaters

Upper immersion heater No (No/Yes)

This is for selecting whether the upper immersion heater (EL 1-3 a/b) should be involved in operation.

Upper extra immersion heater* No (No/Yes)

This is for selecting whether the upper extra immersion heater (E5) should be involved in operation (accessory).

Lower immersion heater* No (No/Yes)

This is for selecting whether the lower immersion heater (E1/E4) should be involved in operation.

Max power immersion heaters kW
 (3x400V) 18.0 (3.3...27.0)
 (3x230V) 14.0 (3.5...21.0)
 (1x230V) 9.0 (1.0...9.0)

This is for selecting the maximum power which all immersion heaters are to emit together.

Tariff EL ext. config. None (NO/NC/None)

The function can block the immersion heater at times of high electricity tariffs by means of an external signal.

This menu defines the Normally Open (NO) or Normally Closed (NC) mode for the external control signal when remotely controlling the function.

For examples of normal mode settings, refer to the "Def. Remote Control" section of the "Advanced/Define" chapter.

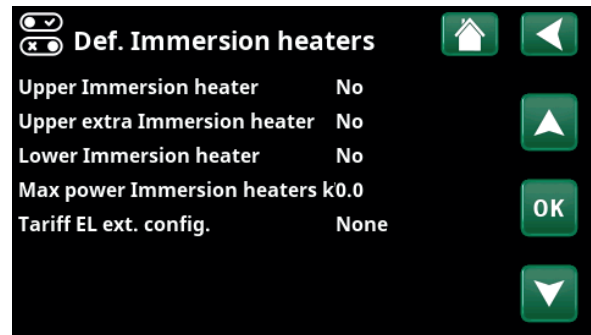

Menu: "Advanced/Define/Immersion heaters".

12.4.8 Define, Wood boiler

Wood boiler No (No/Yes)

Selected if a wood boiler is installed in the system.

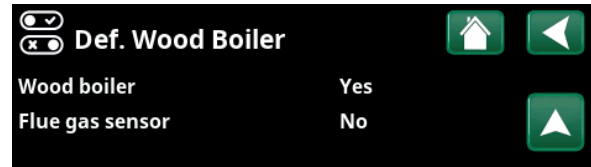

Menu: "Advanced/Define/Wood boiler".

12.4.9 Define, External Boiler

External Boiler No (No/Yes)

Selected if an external boiler is connected to the system.

Ext. boiler sensor No (No/Yes)

Selected if the sensor in the external boiler is connected to the system. If the sensor is not installed, the boiler's charge pump starts at the same time as the boiler.

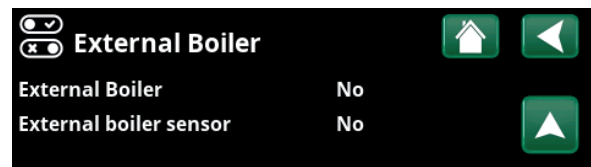

Menu: "Advanced/Define/External boiler".

*The menu bar is not displayed at 1x230V.

12.4.10 Define, Cooling

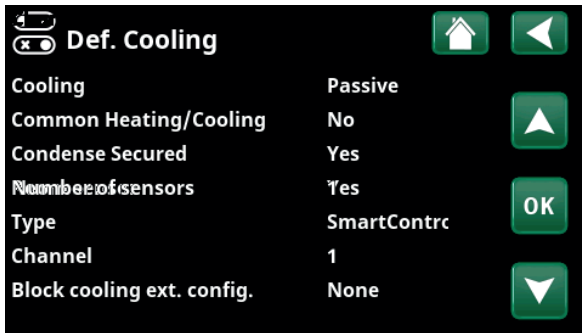

Menu: "Advanced/Define/Cooling".

Cooling Passive (Passive/No)

Select "Passive" to connect passive cooling if the circulation pump (G3), mixing valve Y3, primary flow sensor (B3) and room sensor (B13) are connected to the system.

Common Heating/Cooling No (Yes/No)

"Yes" means that passive cooling and heat are distributed in the same heating circuit.

Condense secured No (No/Yes)

If the system is condensation-proofed, significantly lower temperatures are permitted at various points in the system. **WARNING!** Build-up of condensation in the house structure can lead to damp and damage from mildew.

"No" means a setting range for room temperature of 18-30 °C and "Yes" means a setting range of 10-30 °C.

In the event of doubt, contact a professional for an assessment.

Room sensor Yes (Yes/No/Show)

Selection "Yes" means that room sensors should be connected to the heating circuit.

If "Show" is selected, the room temperature is displayed but the room sensor is not used for control.

! A room sensor must always be used in that part of the property which is to be cooled, as it is the room sensor which determines/controls cooling capacity.

Type Cable/Wireless/Wireless II/SmartControl

Select whether the room sensor for the heating circuit has a wired (via cable) or wireless connection.

- **Cable**
Wired room sensor.
- **Wireless**
Select "Wireless" to connect CTC's wireless room sensors to the heating circuit. See the "CTC Wireless Room Sensor" manual for information on how to connect these sensors.

- **Wireless II**
Select "Wireless II" to connect CTC's wireless room sensor II to the heating circuit. See the "CTC Wireless Room Sensor II" manual for information on how to connect these sensors.
- **SmartControl**
CTC SmartControl is a separate series of wireless accessories. If "SmartControl" is selected, the connection channel must be selected in the row below. CTC SmartControl accessories are connected to the system via the "Advanced/Define/SmartControl" menu. See the separate CTC SmartControl accessories manual.

Block cooling ext. config. None (None/NC/NO)

This menu bar is displayed if an "Input" for remote control is defined for the "Block Cooling" function in the "Advanced/Define/Remote Control" menu.

The function can be used to turn off cooling with the help of a humidity sensor when there is a risk of condensation. This menu defines the Normally Open (NO) or Normally Closed (NC) mode for the external control signal when remotely controlling the function.

For examples of normal mode settings, refer to the "Def. Remote Control" section of the "Advanced/Define" chapter.

12.4.11 Define, Pool

Pool **No (Yes/No)**

Select "Yes" to connect the pool if circulation pumps (G50) and (G51) and pool sensor (B50) are connected to the system.

Block pool ext. config **NO (None/NC/NO)**

This menu bar is displayed if an "Input" for remote control is defined for the "Block Pool" function in the "Advanced/Define/Remote Control" menu.

This menu defines the Normally Open (NO) or Normally Closed (NC) mode for the external control signal when remotely controlling the function.

For examples of normal mode settings, refer to the "Def. Remote Control" section of the "Advanced/Define" chapter.



Menu: "Advanced/Define/Pool".

12.4.12 Define, Ventilation/EcoVent

Ventilation **EcoVent 2x (EcoVent 2x/No)**

This defines whether the CTC EcoVent ventilation product is to be connected to the system.

The menus below define the Normally Open (NO) or Normally Closed (NC) mode for the external control signal when remotely controlling the function. This menu bar is displayed for the functions for which an "Input" for remote control is defined.

Vent. Red. ext. config. **None (None/NC/NO)**

Setting for the "Reduced" ventilation mode.

Vent. Norm. ext. config. **None (None/NC/NO)**

Setting for the "Normal" ventilation mode.

Vent. Boost ext. config. **None (None/NC/NO)**

Setting for the "Boost" ventilation mode.

Vent. Cust. ext. config. **None (None/NC/NO)**

Setting for the "Custom" ventilation mode.

For examples of normal mode settings, refer to the "Def. remote control" section in the "Advanced/Define" chapter.

Refer also to the "Installation and Maintenance Manual" for CTC EcoVent.

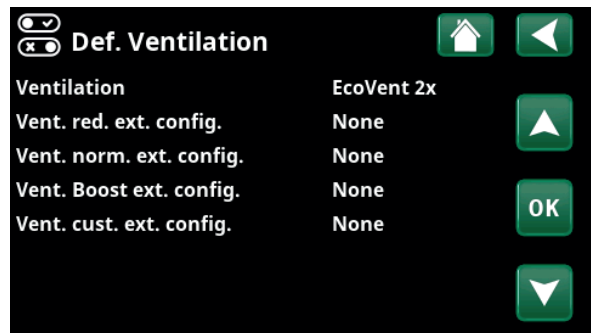

Menu: "Advanced/Define/Ventilation".

12.4.13 Define, Solar collector

Solar collector **No (Yes/No)**

Select "Yes" to connect solar collector if the circulation pump (G30) as well as the "In" solar panel sensor (B30) and "Out" solar panel sensor (B31) are connected to the system.

Type

Specify whether the solar energy heat should be supplied:

- CTC EcoZenith's solar coil ("Coil").
- external heat exchanger ("Exchanger"). Used for larger solar panel installation.

Vacuum **No (Yes/No)**

Specify whether the solar collector are vacuum or flat solar collector.

Borehole recharge (Y31, G31) **No (Yes/No)**

There is an option of recharging the borehole using energy from the solar collector when the ordinary heating and domestic DHW needs have been met.

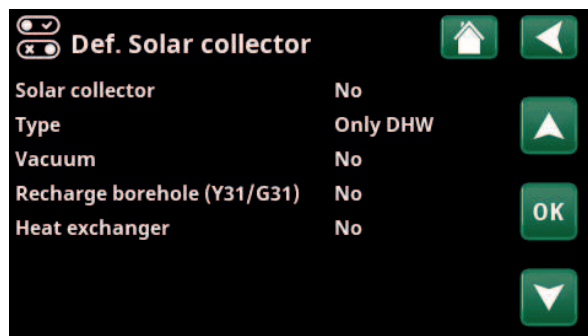

Menu: "Advanced/Define/Solar Collector".

12.4.14 Define, SMS

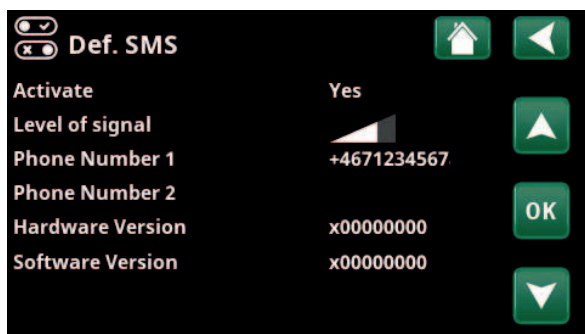

Menu: "Advanced/Define/ SMS".

Activate **No (Yes/No)**

If "Yes" is selected, the menus below are displayed:

Level of signal

The signal strength of the reception is shown here.

Phone Number 1

The first activated phone number is shown here.

Phone Number 2

The second activated phone number is shown here.

Hardware Version

The hardware version of the SMS accessory is shown here.

Software Version

The software version of the SMS accessory is shown here.

NB: For more information about the SMS function, refer to the "Installation and Maintenance Manual" for CTC SMS.

12.4.15 Define, SmartControl

CTC SmartControl is a separate series of wireless accessories.

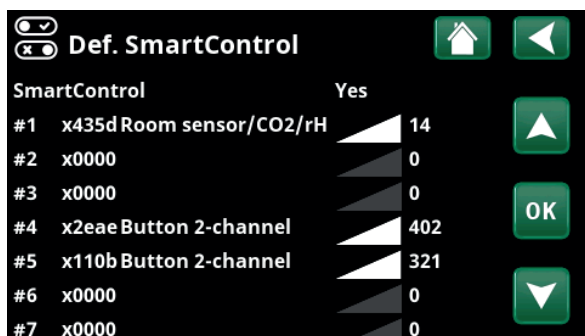

Menu: "Advanced/Define/SmartControl".

SmartControl **No (Yes/No)**

If "Yes" is selected, CTC SmartControl accessories can be connected to the heating circuit. See the connection procedure in the separate CTC SmartControl accessories manual.

12.4.16 Define, Wireless II

CTC Wireless Room Sensor II is a separate series of wireless accessories.

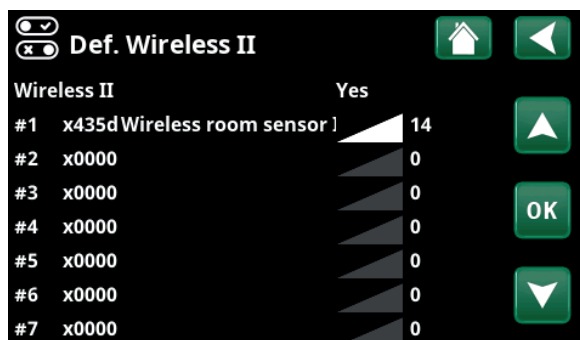

Menu: "Advanced/Define/Wireless II".

Wireless II **No (Yes/No)**

If "Yes" is selected, CTC Wireless Room Sensor II accessories can be connected to the heating circuit. See the connection procedure in the separate CTC Wireless Room Sensor II accessories manual.

12.4.17 Define, Current sensor

Current sensor **No (Yes/No)**

Select "Yes" is current sensors are to be connected to the system.

For more information, refer to the "Current Sensors" section in the "Advanced/Settings" chapter.



12.5 Service

! NB: This menu is intended for the installer only.

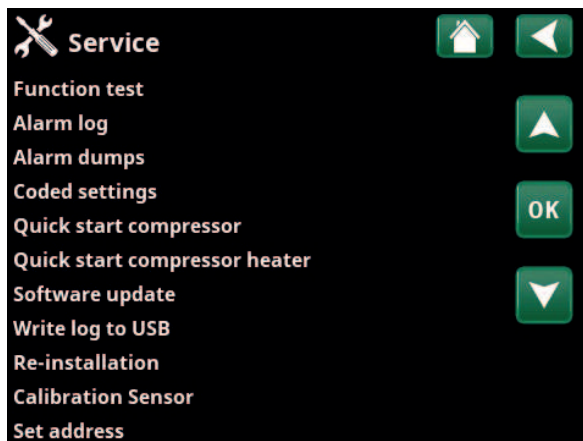

Menu: "Advanced/Service".

12.5.1 Function test

From this menu, the installer can test the connection and function of separate components of the heating circuit. When this menu is activated, all control functions are stopped. The only protection against incorrect operation is the pressure sensors and the immersion heaters overheating protection device. The heat pump returns to normal operation after 10 minutes of inactivity or when exiting the "Function Test" menu. When the menu is opened, all automatic functions are stopped and testing can be performed.

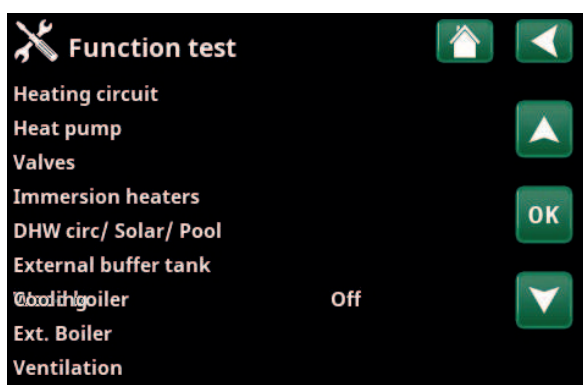

Menu: "Advanced/Service/ Function test".

i When you exit the menu, the heat pump returns to normal operation.

12.5.1.1 Heating circuit*

If several heating circuits have been installed, they will all be displayed here.

Mixing valve (1-) **Close (Close/Open)**

Opens and closes the respective mixing valve.

Rad pump (1-) **Off (On/Off)**

Starts and stops the respective radiator pump.

LED room sensor **Off (On/Off)**

The room sensor alarm functions can be controlled from here. When activated, the respective room sensor's red LED comes on steady.

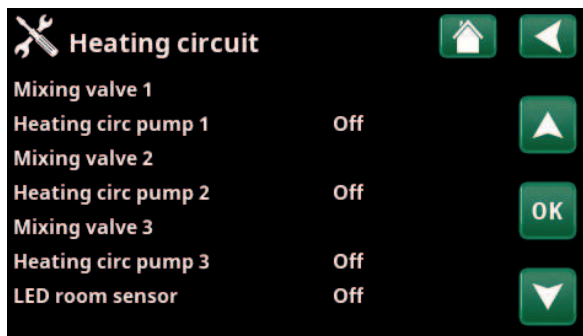

Menu: "Advanced/Service/ Function test/Heating circuit".

*CTC EcoZenith i555 can control up to 3 CTC heat pumps and 3 heating circuits simultaneously.

12.5.1.2 Heat pump*

Select the heat pump (1-*) to be function tested.

HP Compressor Off (On/Off)

When the compressor is being function tested, the brine and charge pump are also operating so that the compressor does not trigger its pressure switches.

HP Brine pump/Fan Off (Off/On)

Function test brine pump or fan (air-to-water HP).

HP Charge pump Off (Off/0...100)

Function test charge pump 0-100%.

Defrost Manually Off (Off/On)

When the "Manual defrosting" function is tested, a defrosting cycle will be performed in the air-to-water heat pump. Defrosting cannot be stopped once it has been started and the defrosting programme will be completed.

Compressor heater Off (Off/On)

Function test compressor heater.

Drip tray heater Off (Off/On)

Function test of the condenser tray heater.

Heating Cable Off (Off/On)

Function test heating cable.

4-way valve (Y11) Off (Off/On)

Function test 4-way valve (Y11). Fitted to air-to-water HP.

Exp. valve /2 % 0 (0...100)

Function test expansion valve. This menu bar is displayed depending on heat pump model.

12.5.1.3 Valves

The following valves are function tested from this menu:

3-way valve (Y21) Down (Up/Down)

12.5.1.4 Immersion heaters

This is where connected immersion heaters are tested by switching them on and off.

Immersion heater L1A/B Off (Off/Low/High/Low+High)

Immersion heater L2A/B Off (Off/Low/High/Low+High)

Immersion heater L3A/B Off (Off/Low/High/Low+High)

Upper extra immersion heater Off (Off/On)

Lower immersion heater Off (Off/Low/High/Low+High)

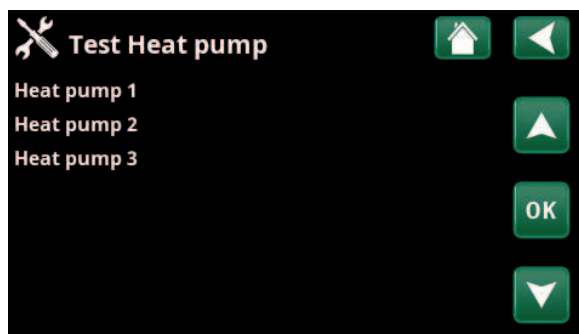

Menu: "Advanced/Service/ Function test/Heat pump".

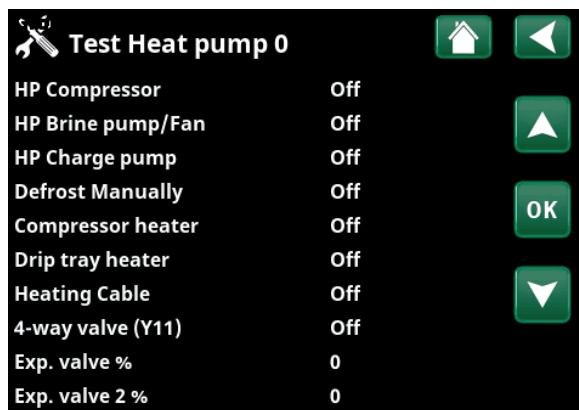

Menu: "Advanced/Service/ Function test/Heat pump/Heat pump 1".

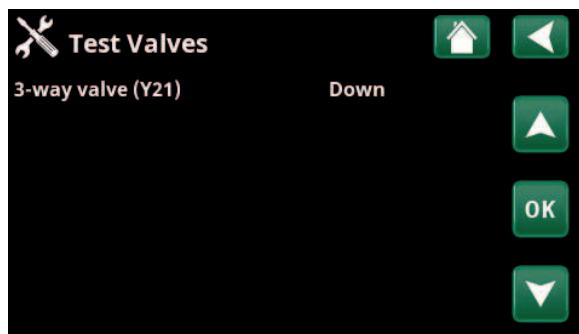

Menu: "Advanced/Service/ Function test/Valves".

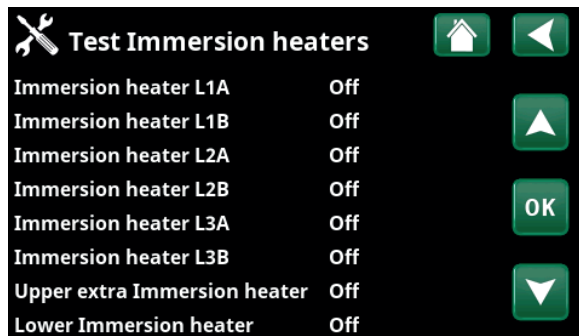

Menu: "Advanced/Service/ Function test/Immersion heaters".

*CTC EcoZenith i555 can control up to 3 CTC heat pumps and 3 heating circuits simultaneously.

12.5.1.5 DHW circulation/ Solar/ Pool

The following pumps/valves are function tested from this menu:

DHW circulation pump (G40) On (On/Off)

Switches the circulation pump "On" and "Off".

DHW tank pump (G41) On (On/Off)

Switches the circulation pump "On" and "Off".

Pump solar panel (G30) 0 (0...100 %)

Tests the circulation pump to full speed (rpm).

Solar heat exchanger pump (G32) 0 (0...100 %)

Tests the solar heat exchanger pump up to full speed (rpm).

Recharge borehole (Y31, G31) Off (On/Off)

Tests the 3-way valve (Y31) and solar heat exchanger pump (G31).

Pool pumps/Valve (G50, G51) Off (On/Off)

Tests the pool pumps and valve (G50, G51).

12.5.1.6 External Buffer tank

The external buffer tank is function tested from this menu.

Pump to tank (G43) Off (Off/On)

Switches the circulation pump "On" and "Off".

Pump from tank (G45) Off (Off/On)

Switches the circulation pump "On" and "Off".

3-way valve (Y40) (Upper tank/Lower tank)

Tests the exchange function between the upper and lower tank.

12.5.1.7 Wood boiler

The wood boiler is function tested from this menu.

Wood boiler Off (Off/On)

Switches the wood boiler "On" and "Off".

12.5.1.8 External boiler

The external boiler is function tested from this menu.

External Boiler Off (Off/On)

Switches the external boiler "On" and "Off".

Charge pump Off (Off/On)

Switches the external boiler's charge pump "On" and "Off".

12.5.1.9 Ventilation

Tap water pump (G5) 0 (0...100 %)

The function of the tap water pump is tested in this menu (G5).

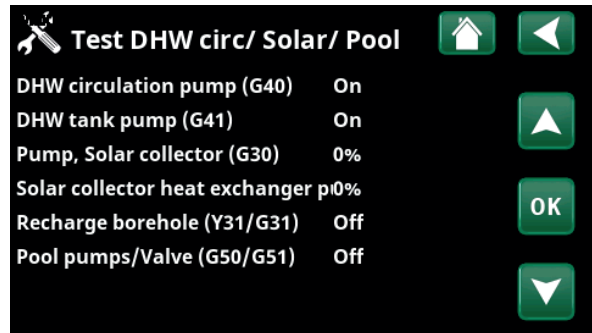

Menu: "Advanced/Service/ Function test/DHW circulation/Solar/Pool".

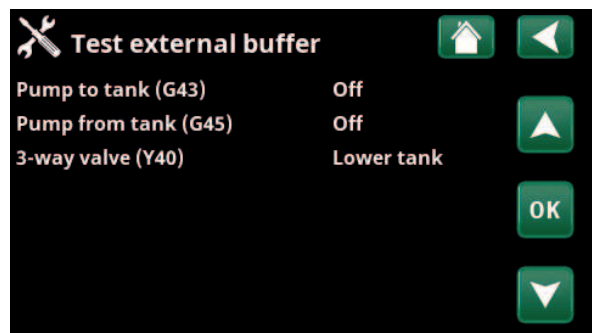

Menu: "Advanced/Service/ Function Test/External Buffer tank".

12.5.2 Alarm log

In the alarm log, up to 500 alarms can be displayed at the same time.

An alarm which reoccurs within an hour is ignored so as not to fill up the log.

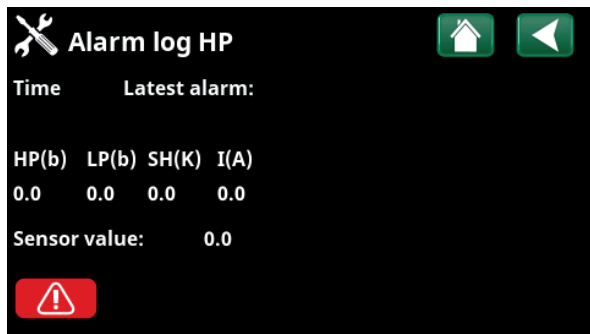

Menu: "Advanced/Service/ Alarm log".

Click an alarm row to see more information about an alarm.

If it is a "sensor alarm", a sensor value will be displayed at the bottom of the page from when the alarm was triggered for further troubleshooting.

For alarms related to the heat pump, values can be displayed from sensors for pressure (HP, LP), temperature (SH=Superheating) and current (I).

! NB: Only an authorised service engineer is allowed to log in to the Factory settings coded option. Severe operational problems and faults may occur affecting the product if values are amended without authorisation. Note that in such cases the warranty terms do not apply.

12.5.3 Alarm dumps

Export the alarms displayed in the alarm log to a USB drive. A dump can consist of one or more alarms as well as specific values before and after the alarm was triggered.



Menu: "Advanced/Service/Alarm dumps".

12.5.4 Coded settings

This menu is intended to set the manufacturer's operational and alarm limits. A 4-digit code must be specified to be able to amend these limits. However, you can also look without any code to see what options feature in the menu.

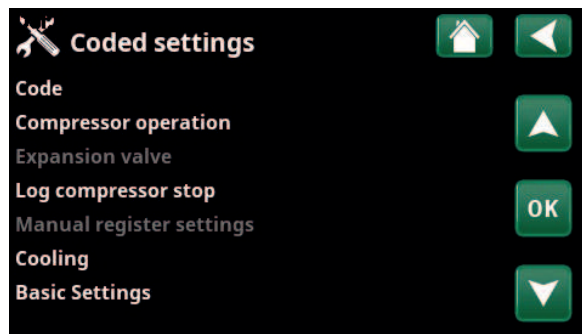

Menu: "Advanced/Service/Coded settings".

12.5.5 Quick start compressor

The delay normally prevents compressor start earlier than 10 mins after compressor stop. The delay is also activated in the event of a power failure, or the first time after production is started. This function speeds up this process.

For "System Types" 1 to 3, the degree minutes loss is set to the value that starts all heat pumps.

12.5.6 Quick start compressor heater

This function starts the compressor preheater, which speeds up the process of getting the compressor ready to start.

Only applies in combination with CTC EcoAir 700M.

12.5.7 Software update

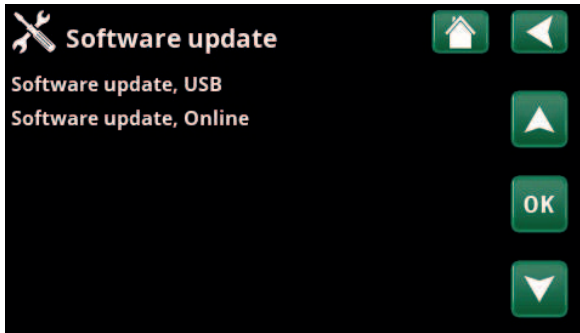

Menu: "Advanced/Service/ Software Update".

The display software can be updated either via USB drive or online. The rows are greyed out until the USB drive is installed or the display is connected to the internet.

Click OK to confirm the upload.

The settings are retained during updating, but the old values are overwritten by any new factory values.

i The product must be registered in myUplink for new software updates to be available for download.

! NB: The power to the product must not be interrupted, under any circumstances, during the update process.

! NB: Turn off the power and always restart the product after software update. Several minutes may pass before the display communicates clearly after restart.

12.5.8 Write log to USB

Intended for service engineers. This function can be used to save logged values to a USB memory stick.

12.5.9 Re-installation

This command relaunches the installation sequence. First, confirm that you want to reinstall to access the installation wizard, refer to the "Installation Guide" and "First Start" chapters.

12.5.10 Calibration Sensor

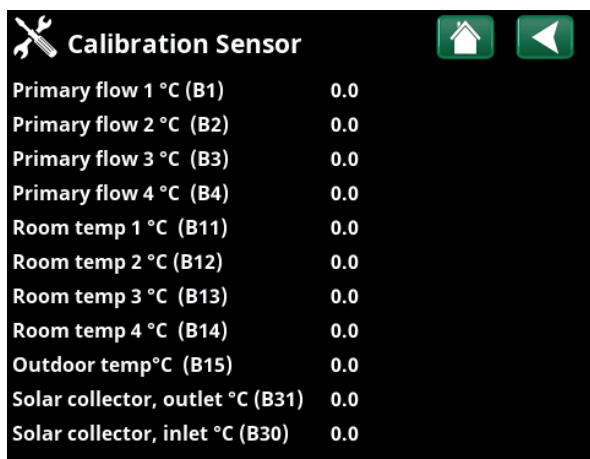

Menu: "Advanced/Service/Calibration Sensor".

Primary flow 1 °C (B1)	0.0 (-3.0...3.0)
Correction of primary flow sensor (B1).	
Primary flow 2 °C (B2)	0.0 (-3.0...3.0)
Correction of primary flow sensor (B2).	
Primary flow 3 °C (B3)	0.0 (-3.0...3.0)
Correction of primary flow sensor (B3).	
Primary flow 4 °C (B4)	0.0 (-3.0...3.0)
Correction of primary flow sensor (B4).	
Room temp 1 °C (B11)	0.0 (-3.0...3.0)
Correction of room sensor (B11).	
Room temp 2 °C (B12)	0.0 (-3.0...3.0)
Correction of room sensor (B12).	
Room temp 3 °C (B13)	0.0 (-3.0...3.0)
Correction of room sensor (B13).	
Room temp 4 °C (B14)	0.0 (-3.0...3.0)
Correction of room sensor (B14).	
Outdoor temp °C (B15)	0.0 (-3.0...3.0)
Correction of outdoor sensor (B15).	
Solar collector, outlet °C (B31)	0.0 (-3.0...3.0)
Correction of temperature sensor on solar collectors for outgoing temperature.	
Solar collector, inlet °C (B30)*	0.0 (-3.0...3.0)
Correction of temperature sensor on solar collectors for incoming temperature.	

12.5.11 Set address

In this menu, heat pumps and expansion boards can be assigned addresses.

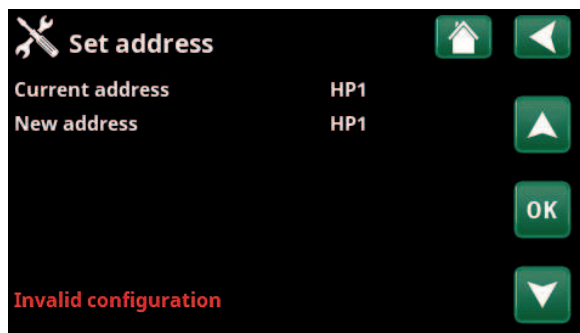

Menu: "Advanced/Service/Set address".

The error message "Invalid Configuration" is displayed if the same heat pump is specified in the "Current address" and "New address" rows, as shown in the menu view on the right.

Actual address	(HP1...HP10, EXP1, EXP2)
Specify the current address of the heat pump or expansion board.	
New address	(HP1...HP10, EXP1, EXP2)
Specify the address to be assigned to the heat pump or expansion board.	

13. Parameter list CTC EcoZenith i555

	Factory setting
Heating circuit	
Program Economy	-
Room temp change °C	-2.0
Off delay, min	30
Program Comfort	-
Room temp change °C	2.0
Off delay, min	30
Max primary flow °C	55
Min primary flow °C	Off
Heating, mode	Auto
Heating off, out °C	18
Heating off, time (min)	120
Heating on, time (min)	120
Night reduction down to °C	5
Room temp. reduced, night red. °C	-2
Room temp. reduced, holiday	-2
Primary flow reduced, night red. °C	-3
Primary flow reduced, holiday	-3
Regulate room temp (min.)	Off
Alarm room temp °C	5
SmartGrid Low Price °C	Off
SmartGrid Overcapacity °C	Off
SmartGrid Blocking	Off
Drying period	Off
Drying period temp °C	25
Drying period mode	Off
Heat pumps	
Delay between HP	30
Delay primary flow temp. (sec.)	180
Prio A/W °C	7
SmartGrid Blocking HP	No
Defrost heating temp min m	10
Defrost heating temp max m	10
Defrost heating temp min °C	10
Defrost heating temp max °C	-10
Heat pump 1-	
Compressor	Blocked
Stop at outdoor temp °C	-22
Charge pump %	50
Cold temp limit	0
Max RPS	120*
Warm temp limit	20
Max RPS warm temp	50
Ext. noise reduction RPS	50

	Factory setting
Compressor stop at brine °C	-5
Brine pump	Auto
Tariff HP	No
Passive cooling brine pump On	Yes
Max. main current A	13/16/20*
HP relay failsafe	0
Function HP relay	-
Immersion heaters	
Upper immersion heater(s) kW	9.0*
Lower immersion heater kW	9.0*
Lower immersion heater °C	30
Delay mixing valve	180
Main fuse A	20
Conv. factor curr. sensors	1
Tariff EL	No
SmartGrid Block immersion	No
SmartGrid Block mixing valve	No
Upper tank	
Program DHW	Economy/ Normal/ Comfort
-Stop temp HP °C	50/55/58
-Extra DHW stop temp °C	60
Start/stop diff °C	5
Max time upper tank (min)	20
Max time lower tank (min)	40
Min. temp °C	45
Add. heat upper tank °C	55
Periodic increase DHW, days	14
Periodic increase DHW, °C	65
Periodic increase DHW, time (min)	Off
Max temp diff end DHW °C	3
Stop DHW diff max °C	3
Run time DHW circ. (min)	4
Time DHW circ. (min)	15
Diff start ext DHW tank	5
SmartGrid Blocking °C	Off
SmartGrid Low Price °C	Off
SmartGrid Overcapacity °C	Off
Time ExtraDHW Remote Contr. (min)	0.0
Lower tank	
Tank max °C	55
Tank min °C	30
Diff tank vs. primary °C	0

*The value may vary depending on the heat pump model.

	Factory setting
Start/Stop diff tank °C	5
Setpoint schedule °C	50
SmartGrid Low Price °C	Off
SmartGrid Overcapacity °C	Off
Solar Panel	
dT max solar °C	7
dT min solar °C	3
Min speed pump %	30
Max lower tank °C	85
Max brine temp °C	18
dT max bedrock °C	60
dT min bedrock °C	30
Solar test tank (min)	4
Test frequency min	30
Winter mode	No
Flow l/min	6.0
Protection collector	
Max temp °C	120
Emergency cooling	Yes
Re-cooling	No
Re-cooling to temp °C	70
Freeze protection	No
Freeze protection °C	-25
Re-cooling stop delay (min)	10
Wood boiler	
Start at flue gas temp °C	100
Start boiler temp °C	65
Boiler temp hyst °C	10
Block HP	No
Recharge delayed	Off
External Boiler	
Ext boiler diff °C	5
Minimum temp ext boiler °C	30
Charge pump delay time (min)	0
Delay stop ext. boiler	0
Priority	High
Delay priority low	120
External buffer	
dT lower ext °C	7
dT start upper °C	7
dT stop upper °C	3
Charge start lower °C	80
dT start lower °C	7
dT stop lower °C	3

	Factory setting
dT setpoint low °C	7
HP charging	Off
Block charging	Yes
Charge temperature °C	60
Charge start °C	20
Stop diff °C	5
Pool	
Pool	Blocked
Pool temp °C	22
Pool diff °C	1.0
Pool priority °C	Low
SmartGrid Blocking °C	Off
SmartGrid Low Price °C	Off
SmartGrid Overcapacity °C	Off
Block pool	No
Cooling	
Room temp. cooling °C	25.0
Active delay	10
Start delay	180
Min flow temp cooling °C	15
Max diff. room temp. cooling °C	5
SmartGrid Low Price °C	Off
SmartGrid Overcapacity °C	Off
Ext. block cooling	No
Power limitation	
Mode	Blocking
Limit value (kW)	4.2
Offset (kW)	0.2
Allow power peak	Yes
Schedule	
Communication	
Ethernet	
DHCP	Yes
Auto DNS	Yes
SNTP server	
Connection speed	100mbit
BMS	
MB address	1
Baudrate	9600
Parity	Even
Stop bit	1
Modbus TCP Port	502
El. prices	

14. Operation and Maintenance

Once your new CTC EcoZenith has been installed, you and your installer should together check that the system is in perfect operating condition. Let the installer show you where the switches, controls, fuses etc. are, so that you know how the system works and how it should be maintained. Bleed the radiators after around three days of operation and top up with water if required.

CTC EcoZenith i555 Pro

The CTC EcoZenith is prepared for connection to a CTC heat pump, wood boiler, other additional boiler, solar energy, passive cooling, borehole charging and pool. The CTC EcoZenith operates fully automatically. The control system turns on additional heat when needed, adapts to wood burning when this occurs, switches to summer mode, etc. For a more detailed description of how CTC EcoZenith's design and functions, refer to the "CTC EcoZenith's Function" chapter.

Safety Valve for Tank and heating circuit

Check regularly that the valve is working properly by manually turning the valve knob. Check that water is coming out of the safety valve discharge. The overflow pipe outlet must always be open. Warning Hot water can drip from the safety valve.

Draining the tank

The tank should be disconnected from the power source when it is being drained. The drain valve is packaged separately and can be connected directly onto one of the lower connections, if one is free, or to a low lying pipe. When draining the whole system, the mixing valve should be fully open, i.e. turned anticlockwise as far as it will go. Air must be supplied to the closed system.

Operation Stop

The product is turned off with the safety switch. If there is a risk of the water freezing, all the water should be drained from the tank and the heating circuit. The DHW coils, which contain about eleven litres, are emptied by feeding a hose all the way down the cold water connections and then siphoning out the water.

Current monitor

The CTC EcoZenith has a current monitor which measures current up to 100 A. If the system is fitted with a current sensor, the property's main fuses are continuously monitored to ensure they are not overloaded. If this should happen, electric stages are disconnected from the immersion heater(s).

Mixing Valve

The mixing valve is operated automatically from the control system, so that the correct temperature, irrespective of the season, reaches the heating circuit. However, where a fault occurs, you can operate the valve yourself by pulling out the knob on the motor and turning it anticlockwise to increase the temperature or clockwise to reduce it.

 Do not forget to reset the mixing valve motor to automatic mode by pushing the knob back in.

Room Sensor

A room sensor, which should always be fitted (up to three room sensors can be connected), ensures that the temperature in the room is always suitable and stable. For the sensor to provide the correct signals to the control unit, radiator thermostats should always be fully open in the area where the room sensor is located. When adjusting the system, always do so with all radiator thermostats fully open. The thermostats can be individually adjusted after a few days in the various rooms.

You can select operation without room sensors in the "Advanced/Define/Heating circuit 1, 2 and 3/ Room sensor: No" menu. This can be done if it is difficult to find a location for the room sensor, if you have several apartments, if the floor heating circuit has separate room sensors, or when using a fireplace or open stove. The alarm LED on the room sensor still functions as normal. If you use the fire or open stove only occasionally, the firing process can affect the room sensor and reduce the temperature supplied to the radiators. It can then get cold in the rooms in other parts of the house. The room sensor can temporarily be deselected during the firing process. The CTC EcoZenith then provides heating to the radiators using the set heating curve. Refer to the chapter on the "House heating curve". The radiator thermostats are closed in the section of the house where a fire is burning.

"Summer Cellar Heat"

You will often want some background heating in basements/recreation rooms/bathrooms in the summer months, to avoid raw, damp air. The CTC EcoZenith takes care of this by setting the minimum permitted primary flow temperature to a suitable temperature (15 to 65°C). See under the menu "Advanced/Settings/heating circuit 1, 2 and 3/Min primary flow °C". This means that the temperature supplied to the radiators will not fall below a selected temperature, for example 30 °C. For this to work, the rest of the house must have functional radiator thermostats or shut-off valves. These shut off the heating in the rest of the house. The function can also be used for floor heating in the bathroom where a warm floor is required during the summer.

Night reduction

With night reduction you have the option of automatically varying the temperature in the house throughout the day, every day of the week. More information can be found in the chapter "Detailed Menu Descriptions/Night reduction".

15. Troubleshooting

CTC EcoZenith i555 Pro is designed to provide reliable operation and high levels of comfort, as well as have a long service life. Various tips are given below which may be helpful and guide you in the event of an operational malfunction.

If a fault occurs, you should always contact the installer who installed your unit. If the installer believes the malfunction is due to a material or design fault, then they will contact CTC to check and rectify the issue. Always provide the product's serial number.

The heating system

If the set room temperature is not obtained, check:

- that the heating circuit is correctly adjusted and is functioning normally. That radiator thermostats are open and the radiators are equally warm all over. Touch the entire radiator surface. Bleed the radiators.

i If you do not have radiator thermostats on the upper floor, you may need to install them.

- that CTC EcoZenith i555 Pro is in operation and that no error messages are displayed.
- that there is sufficient electrical power available. Increase if necessary.
- That the product is not set to the "Max. permitted primary flow temperature" mode with a too low value.
- that "Inclination" has been set high enough. Increase as required. You can find out more on this in the "House Heating Curve" chapter. Also refer to the "Advanced/Settings/Heating circuit 1, 2 and 3" menu.
- That the temperature reduction is set correctly.
- that the mixing valve on the CTC EcoZenith is not in the manual position.

If the heat is not even, check:

- That the placement of the room sensors is appropriate for the house.
- That the radiator thermostats don't interfere with the room sensor.
- That no other heat sources/cold sources interfere with the room sensor.
- that the mixing valve on the CTC EcoZenith is not in the manual position.

i Avoid placing the room sensor close to a stairway due to the uneven air circulation.

Outdoor sensor/Room sensor errors

If a fault occurs with an outdoor sensor, an outdoor temperature of -5 °C is simulated so that the house does not get cold. An alarm appears in the display window.

If a fault occurs with a room sensor, the CTC EcoZenith automatically switches to operating according to the set curve. An alarm appears in the display window.

Resetting after Alarm

You reset the alarm by pressing the reset button on the display. If several alarms are triggered, they are displayed one after the other. A persisting fault must first be rectified before it can be reset. Some alarms are reset automatically if the fault ceases.

Current monitor (protection for main fuses)

CTC EcoZenith i555 Pro has a built-in current monitor. If the system is fitted with a current sensor (included), the property's main fuses are continuously monitored to ensure they are not overloaded. If this should happen, electric stages are disconnected from the heat pump. In the event of high heating demand in combination with, for example, a single-phase engine heater, cooker, washing machine or tumble dryer, the electrical power in the heat pump may be restricted. This may result in inadequate heating or DHW temperatures.

If the heat pump is restricted, this is shown in plain text on the display as "[I012] High current, reduced el.". Consult your electrician to ensure the fuse size is correct, or that the three phases in the house are evenly loaded.

Sound problems

Sudden pressure changes in the tap water system may cause noise. This is due to pressure surges which occur when, for instance, an older type of instant closing mixer is turned off quickly. The fault is not in the CTC EcoZenith, and the problem can be easily rectified by replacing the mixer with a soft closing one. If an unusual sound comes from hard-closing dishwasher and washing machines, this can be remedied using a shock arrestor. A shock arrestor can also be an alternative to soft-closing water taps. Minimising pressure surges benefits the whole of the tap water system throughout the property.

If you hear a rasping sound from the product, check that it has been properly bled. Bleed via the product's safety valve or specially fitted bleed valve, so that any air can be evacuated. Top up with water where required, so that the correct pressure is achieved. If this noise recurs, call a technician to check the cause.

i Don't forget that the radiators may also need bleeding.

15.1 Information messages

Information messages are displayed when appropriate and are intended to inform users about various operational situations.



[I013] Start delay

The compressor is not allowed to start too quickly when it has stopped. The delay is usually at least 10 minutes.

[I002] HC1 Heating off

[I005] HC2 Heating off

[I006] HC3 Heating off

[I007] HC4 Heating off

Shows for each heating circuit that the product is operating in summer mode when only DHW is required, not heating.

[I011] Round circulation

Indicates that round circulation is active. Round circulation is a device which an electricity supplier can fit with the aim of disconnecting high current draw equipment for a short period of time. The compressor and electrical output are blocked when round circulation is active.

[I008] Tariff HP off

Indicates that Tariff has switched off the heat pump.

[I010] Tariff EL Off

Shows that tariff has switched off the immersion heater elements.

[I009] Compressor blocked

The compressor is set to be shut down, e.g. before drilling or digging has been carried out for the collector coils. The product comes with the compressor switched off. This option is selected in the "Advanced/Settings/Heat Pump" menu.

[I012] High current, reduced el.

- The property's main fuses risk being overloaded due to, for example, the simultaneous use of several power-hungry appliances. The product reduces the immersion heaters electrical output during this period.
- 2h max. 6 kW. Immersion heater elements are limited to 6 kW for 2 hours after being switched on. This message appears if more than 6 kW are required during the product's first 2 hours of operation. This is applicable after a power outage or a new installation.

[I021] HC1 Heating mode, remote ctrl

[I022] HC2 Heating mode, remote ctrl

[I023] HC3 Heating mode, remote ctrl

The remote control affects whether the heating is to be on or off. If the heating is switched off, "Heating off, heating circuit 1/2/3" is also displayed.

[I017] SmartGrid: Blocking

[I019] SmartGrid: Low price

[I018] SmartGrid: Overcapacity

The product is externally affected by "SmartGrid". See also "Define/Remote control/SmartGrid".

[I030] Driver block undervoltage

The heat pump has stopped due to insufficient mains voltage. The product will attempt to restart.

[I031] Driver block alarm

The heat pump has stopped due to driver failure; for example, voltage or excessive temperature. The product will attempt to restart.

[I050] Power limitation

Indicates that power limitation is activated.

15.2 Alarm messages



If a fault occurs with e.g. a sensor, an alarm is triggered. A message appears on the display with information about the fault. In the event of an alarm, the LEDs on the display and room sensor also flash.

You reset the alarm by pressing the “Reset alarm” button on the display. If several alarms are triggered, they are displayed one after the other. A persisting fault must first be rectified before it can be reset. Some alarms are reset automatically if the fault ceases.

Alarm messages	Description								
[E055] Wrong phase order	The compressor motor in the connected heat pump must rotate in the right direction. The heat pump checks that the phases are connected correctly; if not, an alarm is triggered. In this case, two of the phases to the heat pump need to be changed. The power supply to the heat pump must be switched off when rectifying this fault. This fault generally only occurs during installation.								
[Exxx] sensor	An alarm is displayed if a fault occurs with a sensor that is not connected or has short-circuited and if the value is outside the sensor's range of measurement. If this sensor is significant to the system's operation, the compressor of the heat pump stops. This requires the alarm to be reset manually after the fault has been rectified. For the sensors below, the alarm is reset automatically after correction: <ul style="list-style-type: none"> [E002] Sensor, boiler (B9) [E007] Sensor, buffer tank (B6) [E012] Sensor, DHW Tank (B5) [E016] Sensor, solar collector In (B30) [E017] Sensor, solar collector Out (B31) [E019] Sensor, pool (B50) [E020] Sensor, boiler (B8) [E030] Outdoor sensor (B15) [E031] Primary flow sensor 1 (B1) [E032] Primary flow sensor 2 (B2) [E033] Primary flow sensor 3 (B3) [E064] Return sensor (B7) [E074] Room sensor 1 (B11) [E075] Room sensor 2 (B12) [E076] Room sensor 3 (B13) [E079] Sensor, solar collector (B33) [E120] Sensor, external boiler (B17) [E141] Sensor, external buffer tank upper (B41) [E142] Sensor, external buffer tank lower (B42) [E143] Sensor, external DHW tank (B43) and for heat pumps 1–3: <table style="width: 100%; border: none;"> <tr> <td>[E003] Sensor, brine in</td> <td>[E036] Sensor, high pressure</td> </tr> <tr> <td>[E005] Sensor, brine out</td> <td>[E037] Sensor, discharge gas</td> </tr> <tr> <td>[E028] Sensor, HPin</td> <td>[E043] Sensor, low pressure</td> </tr> <tr> <td>[E029] Sensor, HPout</td> <td>[E080] Sensor, suction gas</td> </tr> </table>	[E003] Sensor, brine in	[E036] Sensor, high pressure	[E005] Sensor, brine out	[E037] Sensor, discharge gas	[E028] Sensor, HPin	[E043] Sensor, low pressure	[E029] Sensor, HPout	[E080] Sensor, suction gas
[E003] Sensor, brine in	[E036] Sensor, high pressure								
[E005] Sensor, brine out	[E037] Sensor, discharge gas								
[E028] Sensor, HPin	[E043] Sensor, low pressure								
[E029] Sensor, HPout	[E080] Sensor, suction gas								

Alarm messages	Description
[E057] Motor protect high curr.	High current into the compressor has been detected. Press reset and check whether the alarm recurs. If the fault recurs, contact your installer.
[E058] Motor protect low curr.	Low current into the compressor has been detected. Press reset and check whether the alarm recurs. If the fault recurs, contact your installer.
[E035] High pressure switch	The refrigerant's high pressure switch has been triggered. Press reset and check whether the alarm recurs. If the fault recurs, contact your installer.
[E041] Low brine temp	Incoming brine temperatures from bore hole/ground loop are too low. Press reset and check whether the alarm recurs. If the fault recurs, contact your installer to check the dimensions of the cold side.
[E040] Low brine flow	Low brine flow is often caused by air in the collector system, especially immediately following installation. Collectors which are too long can also be a cause. Check also that the brine pump is set to speed 3. Press reset and check whether the alarm recurs. Also check the brine filter that has been installed. If the fault recurs, contact your installer.
[E063] Comm. error relay board	This message is displayed when the display board (A1) cannot communicate with the relay board. (A2)
[E027] Communication error HP	This message is displayed when the display board (A1) cannot communicate with the HP control board (A5).
[E056] Comm. error motor protection	This message is displayed when the HP control board (A5) cannot communicate with the motor protection. (A4)
[E044] Stop, high compr temp	This message appears when the compressor temperature is high. Press reset and check whether the alarm recurs. If the fault recurs, contact your installer.
[E045] Stop, low evaporation	This message appears when the evaporation temperature is low. Press reset and check whether the alarm recurs. If the fault recurs, contact your installer.
[E046] Stop, high evaporation	This message appears when the evaporation temperature is high. Press reset and check whether the alarm recurs. If the fault recurs, contact your installer.
[E047] Stop, low suction gas exp. valve	This message appears when the suction gas temperature is low. Press reset and check whether the alarm recurs. If the fault recurs, contact your installer.
[E048] Stop, low evaporation exp. valve	This message appears when the expansion valve's evaporation temperature is low. Press reset and check whether the alarm recurs. If the fault recurs, contact your installer.
[E049] Stop, high evaporation exp. valve	This message appears when the expansion valve's evaporation temperature is high. Press reset and check whether the alarm recurs. If the fault recurs, contact your installer.
[E050] Stop, low superheating exp. valve	This message appears when the expansion valve's superheat temperature is low. Press reset and check whether the alarm recurs. If the fault recurs, contact your installer.
[E013] EVO off	This message appears when there is a fault with the expansion valve control.
[E052] Phase 1 missing E053] Phase 2 missing E054] Phase 3 missing	This message appears in the event of a phase failure.
[E010] Compressor type?	This message appears if no information about the compressor type is available, contact your installer.
[E026] Heat pump	This message appears if the heat pump is in alarm mode, contact your installer.
[E061] Max. thermostat	If the heat pump has been stored in an extremely cold place, the max thermostat may have been triggered. You reset it by pressing in the button on the electrical switchboard behind the front panel. Always check that the max thermostat has not been triggered during installation.
[E001] Risk of freezing	Alarm indicating that the temperature of the outgoing water from the heat pump (HP out) is too low for defrosting. The water volume in the system may be too low. The flow may be too low. (Applies to CTC EcoAir)

Alarm messages	Description
[E163] Defrost max time duration	The heat pump has not had time to complete defrosting within the maximum time. Make sure that any ice on the evaporator has disappeared.
[E087] Driver	Press reset and check whether the alarm recurs.
[E088] Driver: 1 - [E109] Driver: 29 Driver fault.	If the fault recurs, contact your installer and tell them the error code number where applicable.
[E117] Driver: Offline	Communication error. The junction box and driver of the heat pump are not communicating.

15.3 Critical alarms - Risk of freezing



[E135] Risk of freezing (after four alarms, a new alarm is displayed [E218])

[E211] Risk of freezing low flow (after four alarms, a new alarm is displayed [E219])

[E216] HP flow temp diff (after four alarms, a new alarm is displayed [E220])

[E217] HP Charge pump flow (after four alarms, a new alarm is displayed [E221])

If a critical alarm is shown on the display, take the action described below. Confirm the alarm by entering code 4005 in the display menu "Advanced/Service/Coded settings/Code".

Please note: The critical alarms can be acknowledged three times by entering code 4005. **After four alarms, the heat pump is blocked;** in this case, contact the installer. After one year of operation without any alarms, the critical alarms are reset.

[E135] Risk of freezing

Applies to all air/water heat pumps.

Alarm conditions

If the temperature of the water exiting the heat pump (HP out) is lower than 15 °C during a defrost period or if there is more than 15 °C difference between HP in and HP out for more than 20 seconds.

Possible cause

- The circuit temperature and/or flow rate is too low.
- If the sensors (HP in and HP out) do not display the correct value, alarm [E135] can be generated. Check the temperatures using an external thermometer.

Action

- Ensure that the return flow of the heating circuit is at a minimum of 25°C during a defrost period. In the event of low temperature, contact the installer.
- Supplement with a volume tank.
- Check the circulation pump, dirt filter, pipe system and pipe size to ensure flow requirements are met.
- Check the sensors (HP in and HP out) and replace as required.

[E211] Risk of freezing low flow

Applies to CTC EcoAir 600M with the "Flow Sensor" accessory installed, and CTC EcoAir 700M.

Alarm conditions

The flow is less than 10 l/min (CTC EcoAir 610M/614M/708M/712M) or 15 l/min (CTC EcoAir 622M/720M) for more than 30 seconds during a defrost period.

Possible cause

- The circuit temperature and/or flow rate is too low.

Action

- Check the circulation pump, dirt filter, pipe system, pipe size and flow sensor to ensure flow requirements are met.

[E216] HP flow temp diff

Applies to CTC EcoAir 600M/700M.

Alarm conditions

The difference between HP in and HP out exceeds 12 °C in heat operation for more than 15 minutes.

Possible cause

- The circuit temperature and/or flow rate is too low.

Action

- Check the dirt filter, pipe system and speed settings of the circulation pump to ensure flow requirements are met.
- Check the sensors (HP in and HP out) and replace as required.

[E217] HP Charge pump flow

Applies to CTC EcoAir 400.

Alarm conditions

The charge pump speed exceeds 70% during heat operation for more than 30 minutes.

Possible cause

- The circuit temperature and/or flow rate is too low.

Action

- Check the dirt filter, pipe system and speed settings of the circulation pump to ensure flow requirements are met.

Critical alarms during cooling operation

If the critical alarms appear during cooling operation, it is an indication that the base flow is set too low. Remedy by checking and adjusting the base flow.

i If the sound of the circulation pump is perceived as disturbing during constant running up and down, the basic flow rate should be set higher.

16. Transportation, unpacking and installation

This section is intended for the technician responsible for one or more of the installations necessary for the CTC EcoZenith i555 Pro to perform according to the property owner's wishes. Take your time going through functions and settings with the property owner and answer any questions. Both you and the CTC EcoZenith i555 Pro benefit from ensuring the user has completely understood how the system operates and should be maintained.

16.1 Transportation

Transport the unit to the installation site before removing the packaging.

Handle the CTC EcoZenith i555 Pro in one of the following ways:

- Forklift.
- Lifting eye which is fitted in the socket in the middle of the CTC EcoZenith i555 Pro top.
- Lifting band around the pallet. NB: Can only be used with the packaging on.
- Remember that the product has a high centre of gravity and should be handled with caution.

! The product must be transported and stored in an upright position.

16.2 Unpacking

When the CTC EcoZenith i555 Pro has been placed at the installation site, the packaging can be removed. Check that the product has not been damaged in transit. Report any transport damage to the carrier.

16.3 Fitting rear insulation and plastic top cover

The rear insulation sections and top cover should be fitted before the CTC EcoZenith i555 Pro is placed against a wall or in a corner for pipe and electrical connection. These parts are delivered separately and they are easier to fit if there is space around the unit.

Begin with the left rear insulation. Turn out the insulation, locate it in the recesses in the front insulation and then turn it in against the tank. Repeat this procedure for the right rear insulation. Note that the right rear insulation needs to be turned out quite a lot for it to locate easily in the recesses.

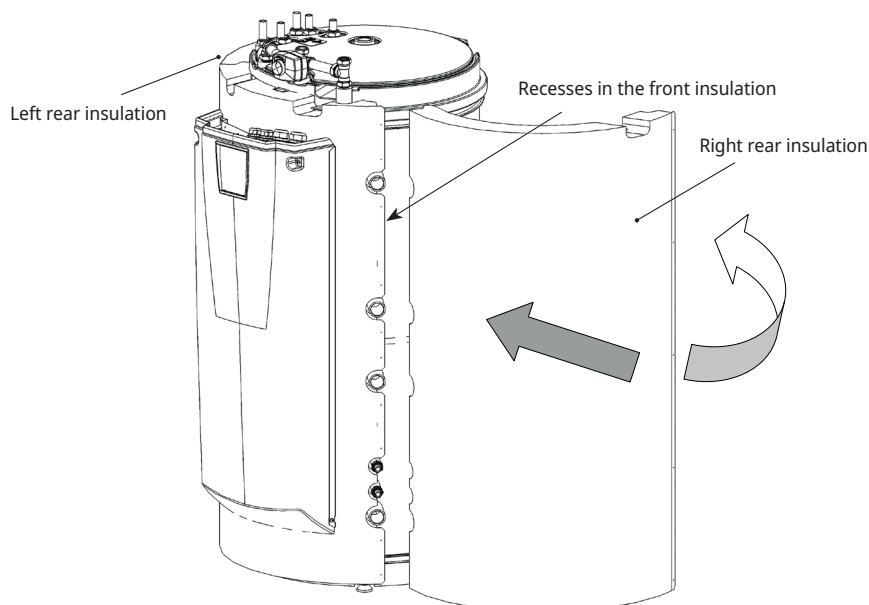

When the rear insulation is in place, tension bands can be used to hold it firmly against the tank. Attach the insulation sections to each other using the 25 graphite-grey screws provided. The screw positions have been pre-drilled.

! The tension bands can scratch the surface of the insulation. Use a piece of cardboard or similar to protect it.

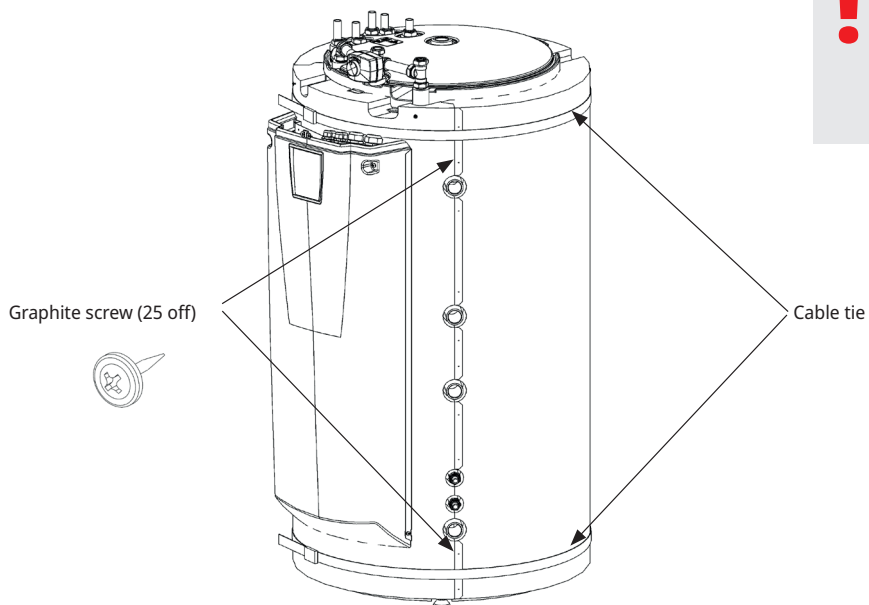

Fit the plastic top at the front and tip it backwards to locate it under the mixing valve actuator. Fit the 4 zinc-grey screws provided in the pre-drilled holes. Ensure that the plastic top cover is correctly aligned with the front.

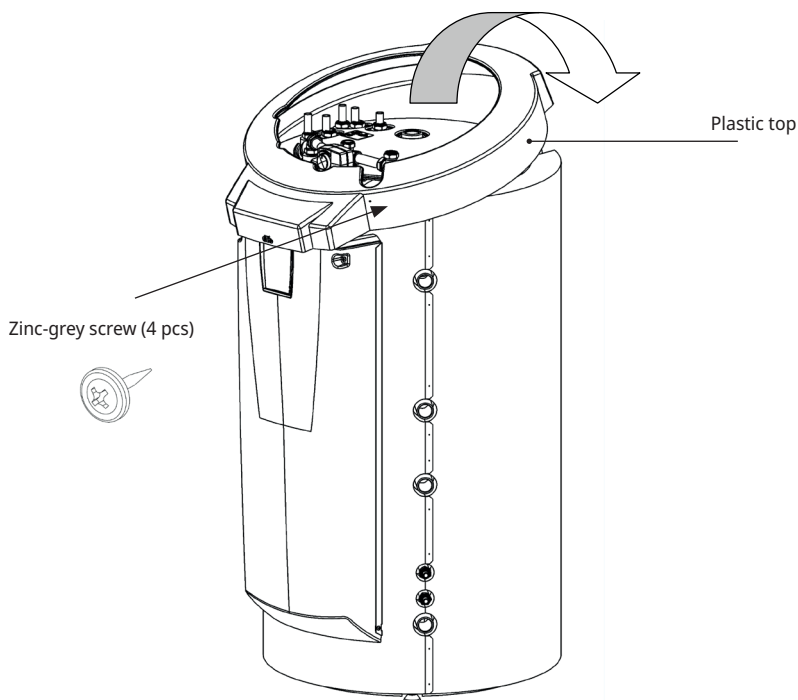

17. Parts list

01. CTC EcoZenith i555 Pro upper tank	B1. Sensor, primary flow to heating circuit 1
02. CTC EcoZenith i555 Pro lower tank	B2. Sensor, primary flow to heating circuit 2
03. Wood boiler	B3. Sensor, primary flow to heating circuit 3
04. External boiler (pellets, oil, gas, electricity, other)	Alt: Sensor, primary flow CTC EcoComfort (Cooling)
05. Plate heat exchanger – solar heat	B5. Sensor, tank upper
06. Buffer tank 1	B6. Sensor, lower tank
07. Buffer tank 2	B7. Sensor, radiator return
08. Heating circuit 1	B8. Sensor, flue gas wood boiler
09. Heating circuit 2	B9. Sensor, wood boiler
10. Heating circuit 3	B11. Room sensor 1
11. Finned coil – solar heat	B12. Room sensor 2
12. Charge equipment – external buffer tank	B13. Room sensor 3
13. External DHW tank	Alt: Room sensor, CTC EcoComfort (passive cooling)
14. Plate heat exchanger – pool	B15. Sensor, outside
15. Pool	B17. Sensor, external boiler
16. Liquid/water heat pump (CTC EcoPart)	B30. Sensor, solar collector return
17. Solar collector (flat panel or vacuum tube)	B31. Sensor, primary flow solar collector
18. Plate heat exchanger – recharging borehole	B33. Sensor, solar coil
19. Charge equipment, such as Laddomat 21	B41. Sensor, external buffer tank upper
20. Non-return valve, DHW system	B42. Sensor, external buffer tank lower
21. Electric shut-off valve, heating circuit 1	B43. Sensor, external DHW tank
22. Non-return valve, DHW system	B50. Sensor, pool
23. Non-return valve, DHW system	G1. Circulation pump, heating circuit 1
24. Non-return valve, solar heat	G2. Circulation pump, heating circuit 2
25. Non-return valve, heat pump 1	G3. Circulation pump, heating circuit 3
26. Non-return valve, heat pump 2	Alt: Circulation pump, CTC EcoComfort
27. Non-return valve, heat pump 3	G6. Circulation pump, flue gas controlled
28. Control valve, DHW system	G11. Circulation pump, heat pump 1
29. Control valve, DHW system	G12. Circulation pump, heat pump 2
30. Control valve, DHW system	G13. Circulating pump, heat pump 3
31. 3-way valve - manual, external DHW tank	G14. Circ pump integrated in the accessory CTC EcoComfort
32. Mixing valve, DHW system	G30. Circulation pump, solar panel
34. Non-return valve, DHW system	G31. Circulation pump, recharging borehole
35. Non-return valve, DHW system	G32. Circulation pump, plate heat exchanger – solar heat
36. Non-return valve, brine system	G40. Circulation pump, DHW
37. Heat exchanger passive cooling (CTC EcoComfort)	G41. Circulation pump, external DHW tank
38. Non-return valve passive cooling	G43. Circulation pump, external buffer tank charging
39. Pipe for floor cooling/fan convector	G44. Circulation pump, external boiler
40. Fan convector	G45. Circulation pump, external buffer tank discharging
41. Non-return valve, low pressure drop (only for passive cooling)	G50/G51. Circulation pump, pool and pool charging
HP 1. Heat pump 1	Y1. Mixing valve, heating circuit 1
HP 2. Heat pump 2	Y2. Mixing valve, heating circuit 2
HP 3. Heat pump 3	Y3. Mixing valve, heating circuit 3
E1/E4. Immersion heater lower tank	Y21. 3-way valve, heat pump - in
EL 1–3 a/b. Immersion heater – upper tank 1	Y22. 3-way valve, heat pump - out
E5. Immersion heater upper tank 2	Y31. 3-way valve, recharging borehole
	Y40. 3-way valve, charging/discharging buffer tank

18. Schematic diagram

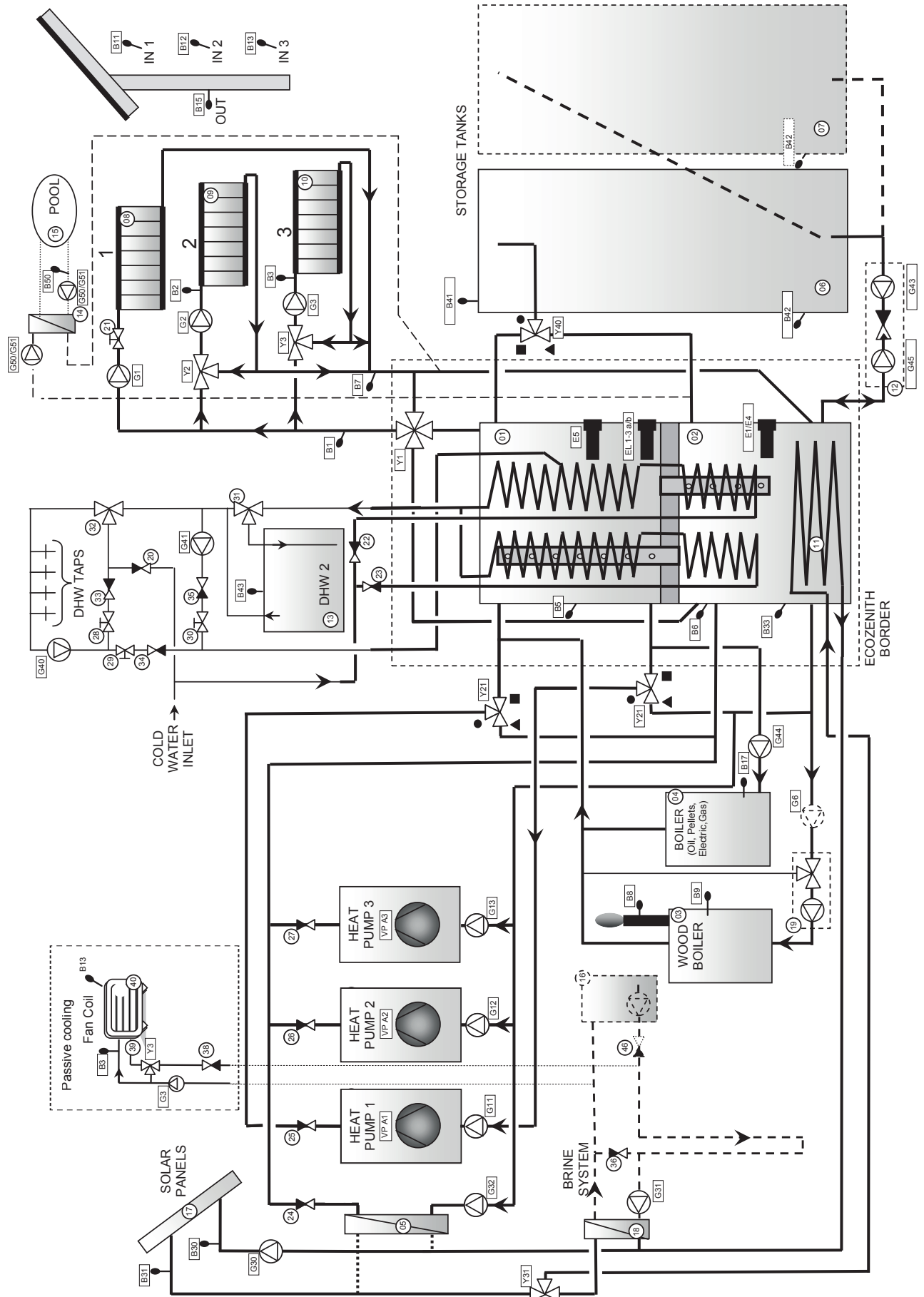

19. Pipe installation

The installation must be carried out in accordance with current heating and DHW standards. The product must be connected to an expansion vessel in an open or closed system. Do not forget to flush the heating circuit clean before connection. Perform all the installation settings based on the description in the chapter on "First start". See the chapter on the CTC EcoZenith's functions in the section for the property owner for more information on the function of the various parts of the system.

This chapter contains the main connections for the CTC EcoZenith, plus additional installations such as heat pumps, tanks, solar energy, pool, passive cooling, recharging borehole, DHW circulation and external gas, oil or pellet boiler. The instructions for the relevant additional product should be followed.

Refer also to the "Electrical installation" chapter.

Connections, placement and dimensions

See Technical data in the section for the property owner.

Pipe connections on the unit

Connect the pipes as shown in the schematic diagram for pipe connections. Also refer to Technical data in the section for the property owner for connection dimensions and placement. If annealed copper pipe is used, fit support sleeves.

Circulation pumps – heating circuit

The circulation pumps are fitted to the primary flow pipe from the CTC EcoZenith to the respective heating circuits and receive their power supply from the CTC EcoZenith (refer to the "Electrical Installation" chapter).

Mixing valve

Install a mixing valve where there is outgoing tap DHW in order to avoid the risk of scalding at the property's tap DHW points.

Safety valves

The CTC EcoZenith's safety valves for the tap water circuit and boiler are packaged separately. Connect the waste pipes to the waste system directly to the floor gully or, if the distance is more than two metres, to a funnel. Water may drip from a connected waste pipe. The waste pipe must incorporate a fall towards the floor gully, be installed so that there is no risk of freezing and be left open to the atmosphere/without pressure. The length of the waste pipe may not exceed two metres, unless in these cases it exits into a funnel.

Filling valve – heating circuit

Fit a filling valve between the cold water connection and the radiator return pipe, or between the cold water pipe and the expansion pipe. The filling valve must be provided with a non-return valve (to prevent backflow).

Drainage valve

Fit the drain valve (separate package) to one of the CTC EcoZenith's lower connections. The adapter for this is provided in the package. The drain valve can also be fitted into a low lying pipe.

Manometer – system pressure

Fit a manometer to the expansion pipe or radiator return pipe.

Expansion vessel connection

The CTC EcoZenith is best connected to a closed expansion vessel. If an open system is used, the distance between the expansion vessel and the highest placed radiator must not be below 2.5 m, in order to avoid introducing oxygen into the system.

Insulation

To ensure best efficiency, make sure that after installation you insulate all pipe parts, pipe unions and used and unused plugged connections. Use the insulation parts provided, and supplement these with insulation of Armaflex type having minimum 10–15 mm thickness, or equivalent. Make sure the insulation at the connections reaches all the way to the CTC EcoZenith's own insulation and that it has no gaps, so as to prevent any loss of heat.

Pressure/level switch

In some cases, extra protection is required due to local requirements or provisions. For example, the requirement in some areas is for the system to be installed within a water catchment area.

The pressure/level switch connects to terminal blocks K22/K23/K24/K25 and is then defined in the "Advanced/Define/Def. Heat Pump" menu. If there is a leak, the compressor and brine pump stop and the "Flow/level switch" alarm appears on the display.

19.1 Heating circuit

The CTC EcoZenith i555 Pro can be connected to three different heating circuits with separate room sensors.

Mixing valve (Y1) is the main mixing valve and feeds heating circuit 1. Mixing valves (Y2) and (Y3) for heating circuits 2 and 3 are sub-mixers. This means that mixing valve (Y1) controls the maximum temperature to mixers (Y2) and (Y3).

For one or two sub-mixing valves (heating circuits 2 and 3) to be operative when heating circuit 1 is not operative, valve (21) must be connected to radiator pump (G1) so that the valve closes when the radiator pump for heating circuit 1 is not operative. This is useful, for example, if floor heating in a bathroom is preferred during the summer.

Note that the expansion vessel and safety valve for the heating circuit are not included in the schematic diagram.

Also refer to the "Heating circuit" section in the "Detailed Menu Descriptions" chapter (Advanced/Settings/Heating Circuit 1-3).

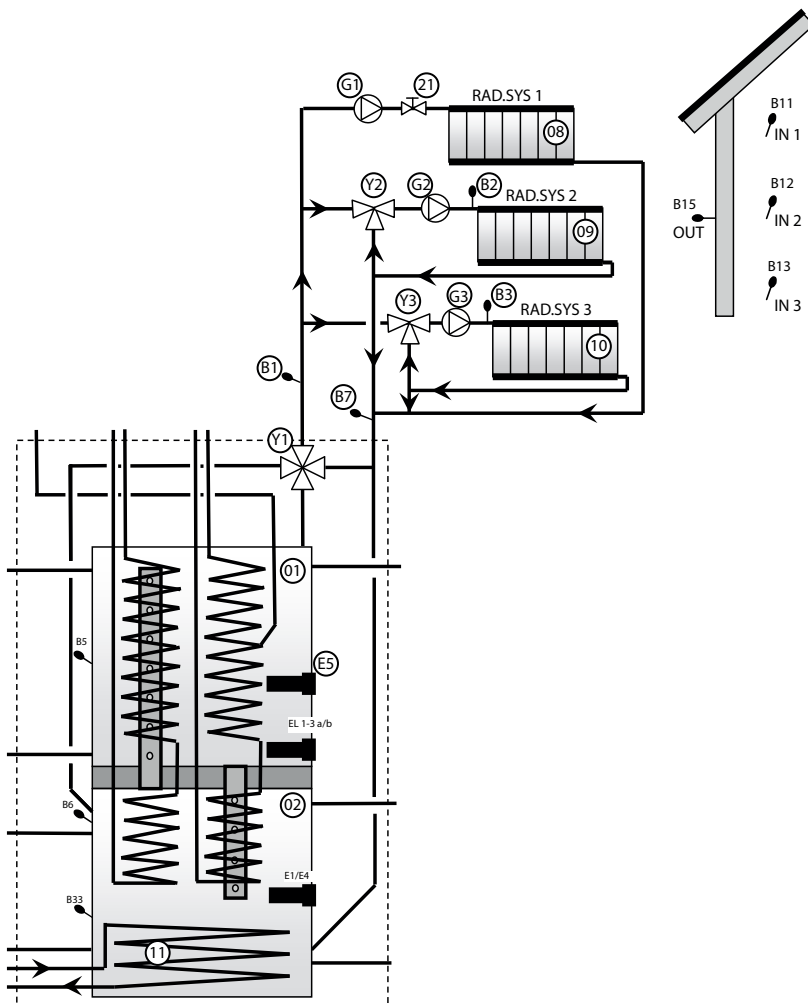

i Valve 21 must be connected if heating circuit 2 or 3 is used.

19.2 Heat pump

Heat pump 1 is connected to 3-way valves for changing between the upper and lower tanks. Heat pumps 2 and 3 are connected directly to the lower tank for supplying radiators.

Ensure that the ports on the 3-way valves (Y21) are set as in the schematic diagram. The ports ● must always be connected to heat pump 1.

If it is necessary to swap ports (■ and ▲), two jumpers in the actuator must be reconnected. See the chapter on Electrical installation for more information.

Note that the last heat pump in a series connection must be in the terminated position, i.e. DIP switch 2 on the last heat pump must be in the ON position and the other heat pumps in the OFF position. For more information, refer to the Installation and Maintenance instructions of the respective heat pump.

The 3-way valves (Y21) and the circulation pumps (G11), (G12) and (G13) are CTC accessories.

Also refer to the "Heat pump" section in the "Detailed Menu Descriptions" chapter (Advanced/Settings/Heat Pumps 1-3).

! Only heat pump 1 may be connected to the 3-way valves (Y21).

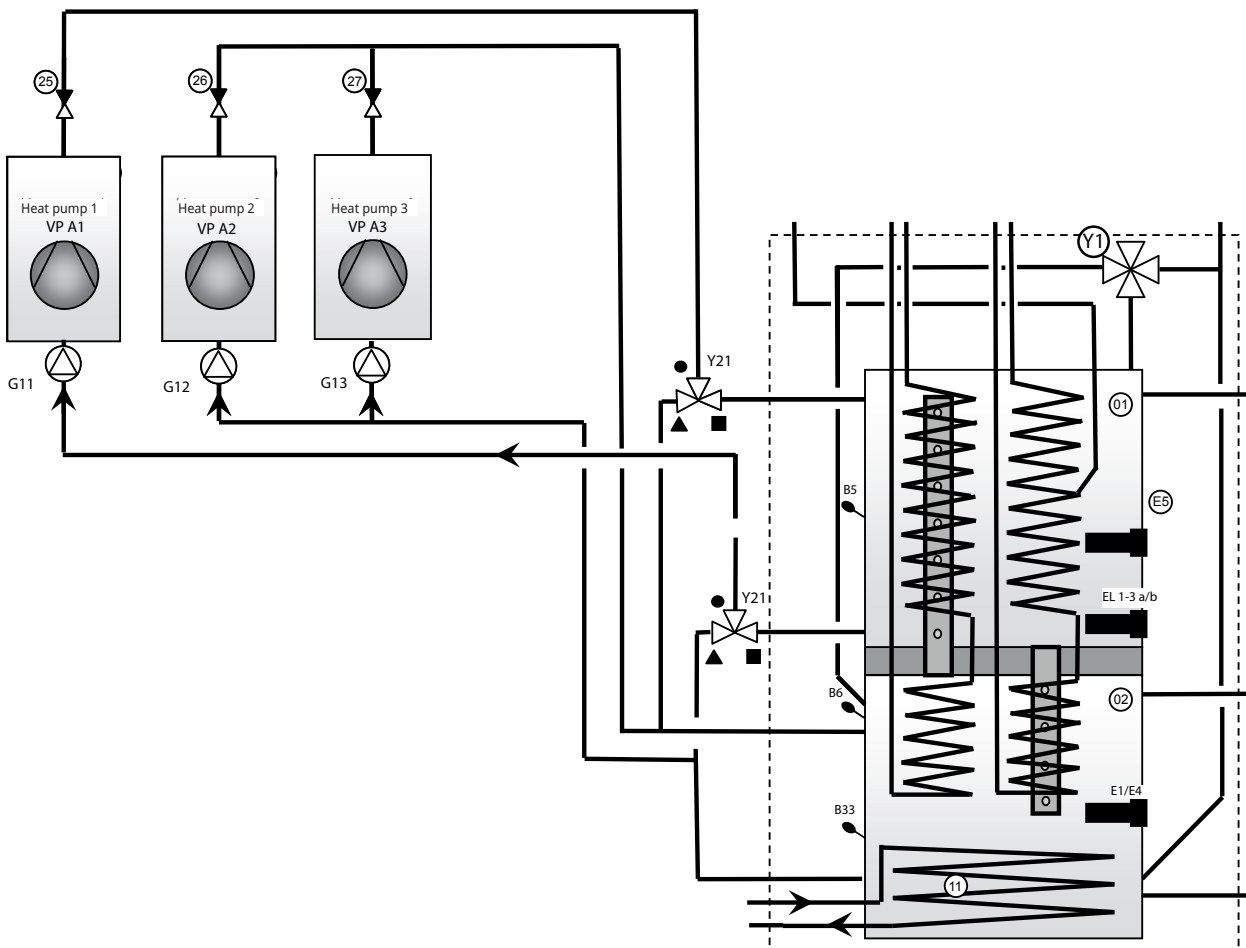

19.3 Solar heating

Solar panels (17) can be connected directly to the CTC EcoZenith's built-in solar coil (11).

The solar coil is the finned type. The fluid is pumped from the coil by a speed controlled solar pump (G30). In a larger system with several solar panels of more than about 10 m², the panels are connected to an intermediate heat exchanger (05) and the changing solar energy is pumped to the CTC EcoZenith's lower tank by a speed controlled pump (G32). The pumps are powered by a separate source and their speed is controlled by the CTC EcoZenith. Refer to the "Electrical installation" chapter for more information.

The diverting valve (Y31), plate heat exchanger (18), charge pump (G31) and non-return valves (36) and (41) are used to recharge solar energy to the boreholes/ground loop. The CTC EcoZenith also starts the brine pump in the liquid/water heat pump (CTC EcoPart) when recharging is taking place. This means that the charge pump for recharging the borehole (G31) is then needed to compensate for the pressure drop across the plate heat exchanger (18), thus ensuring, in combination with the brine pump, sufficient flow through the heat collector and exchanger.

Speed controlled pumps (G30), (G31) and (G32), 3-way valve (Y31) and plate heat exchanger (05), (18) are CTC accessories.

Also refer to the "Solar panels" section in the "Detailed Menu Descriptions" chapter (Advanced/Settings/Solar Panels).

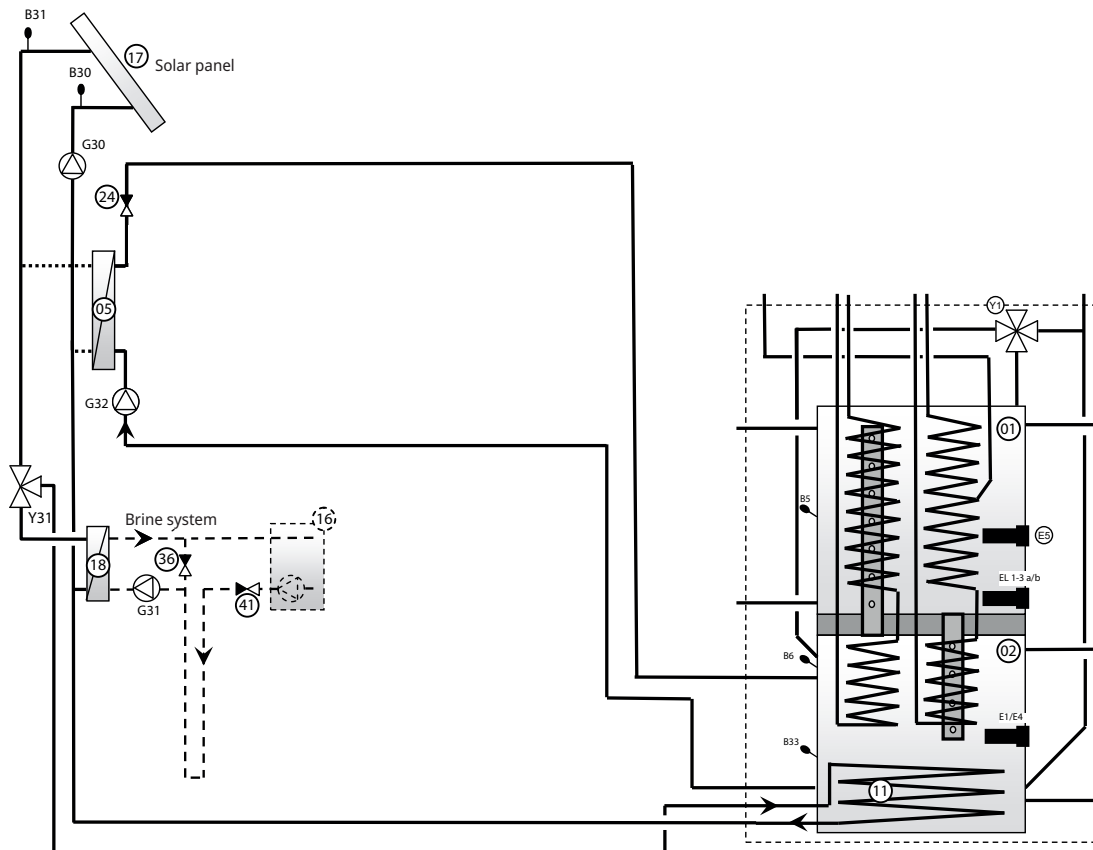

19.4 DHW

Figure 1 Shows how DHW circulation can be connected to the CTC EcoZenith. The domestic hot water is circulated by pump (G40). New DHW from the finned coil is mixed in by the mixing valve (32), and cooled water is released down to the coil for reheating. Only a part of one coil in the upper tank is used for circulation. The non-return valves (22), (23), (33) and (34) are needed to ensure that circulation proceeds as intended. The control valves (28) and (29) make it possible to set the correct flow rate in the circuit

Figure 2 Shows how an external DHW tank is connected. The manual 3-way valve (31) is set to allow DHW to pass via the external DHW tank. The sensor (B43) detects when the temperature drops in the external DHW tank and starts the pump (G41). Cooled DHW is pumped via the non-return valve (35) and control valve (30) down to the part of the coil used for circulation. The water is heated in the coil and is stored in the external DHW tank. When the sensor (B43) reaches its setpoint, the pump stops. The manual 3-way valve is used to include or exclude the external tank, as desired, in operation. When drawn off, the DHW passes through the entire coil and then via the external DHW tank. The non-return valves (22), (23) and (35) are needed to ensure that circulation proceeds as intended. The control valve (30) allows the desired flow of the circuit to be adjusted.

Also refer to the "Upper tank" section in the "Detailed Menu Descriptions" chapter (Advanced/Settings/Upper Tank).

Note that the safety valves for the tap water system are not entered in the schematic diagrams.

Figure 1 DHW circulation

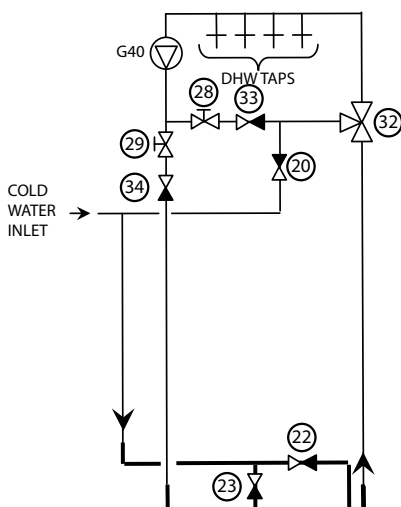
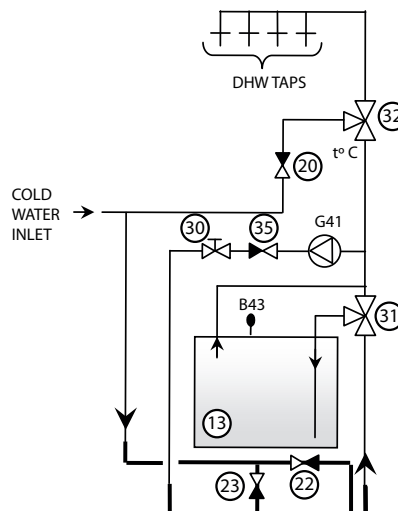

Figure 2 External DHW tank



19.5 Wood boiler

The upper and lower connections are used for connecting a wood boiler to the CTC EcoZenith. Alternatively, the expansion connection and lower connection are used. This means that the flow from the wood boiler passes through the entire CTC EcoZenith. Charging from the wood boiler is done using the charge pump (G6) or by external charge group, such as Laddomat 21. The charge pump in the charge group must be controlled from the wood boiler.

Also refer to the "Wood boiler" section in the "Detailed Menu Descriptions" chapter (Advanced/Settings/Wood Boiler).

19.5.1 Pump controlled by flue gas temperature

The pump (G6) is controlled by the temperature of the flue gas sensor (B8) and/or boiler sensor (B9). The pump starts when the flue gas sensor (B8) and/or boiler sensor (B9) senses the set temperature for wood boiler/stove operation. The pump has no on/off delay, which means that if the water volume around the stove or boiler in question is excessive, the circulation may initially cool down the CTC EcoZenith. If sensors (B8) and/or (B9) are installed, the CTC EcoZenith can enter wood status. This is particularly important when the installation consists of both wood and solar heat, since this affects discharging to storage tanks.

Also refer to the "Wood boiler" section in the "Detailed Menu Descriptions" chapter (Advanced/Settings/Wood Boiler).

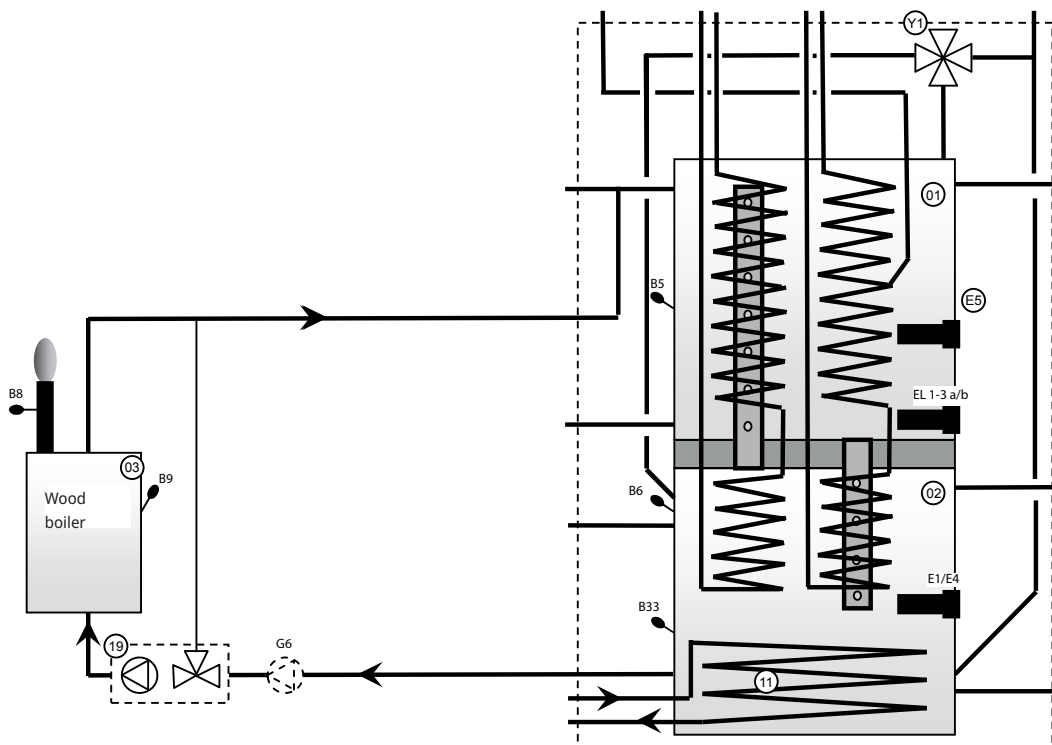

NB: Connecting with charge group (19) reduces the risk of condensation forming and corrosion in the hearth.

19.6 Buffer tanks

One or more buffer tanks can be connected to increase the water volume; this is done most commonly in connection with wood or solar energy operation. When the CTC EcoZenith controls the charging of the wood boiler and solar energy, buffer tanks can be charged with lower temperatures and thus higher efficiency.

The 3-way valve (Y40) is connected to the upper connection from both the CTC EcoZenith's upper and lower tanks and then to the top of the first buffer tank. Ensure that the ports on the 3-way valve (Y40) are set as in the schematic diagram. If it is necessary to swap ports (■ and ▲), two jumpers in the actuator must be reconnected. See the chapter on Electrical installation for more information. If several buffer tanks are used, they must be connected in series. The return from the buffer tanks goes to the lower connection on the CTC EcoZenith's lower tank via the charge equipment (12). The charge equipment and 3-way valve are "External tank charging" accessories. The sensors (B41) and (B41) are used to control the charging and discharging of the buffer tanks.

Also refer to the "External buffer tank" section in the "Detailed Menu Descriptions" chapter (Advanced/Settings/External Buffer Tank).

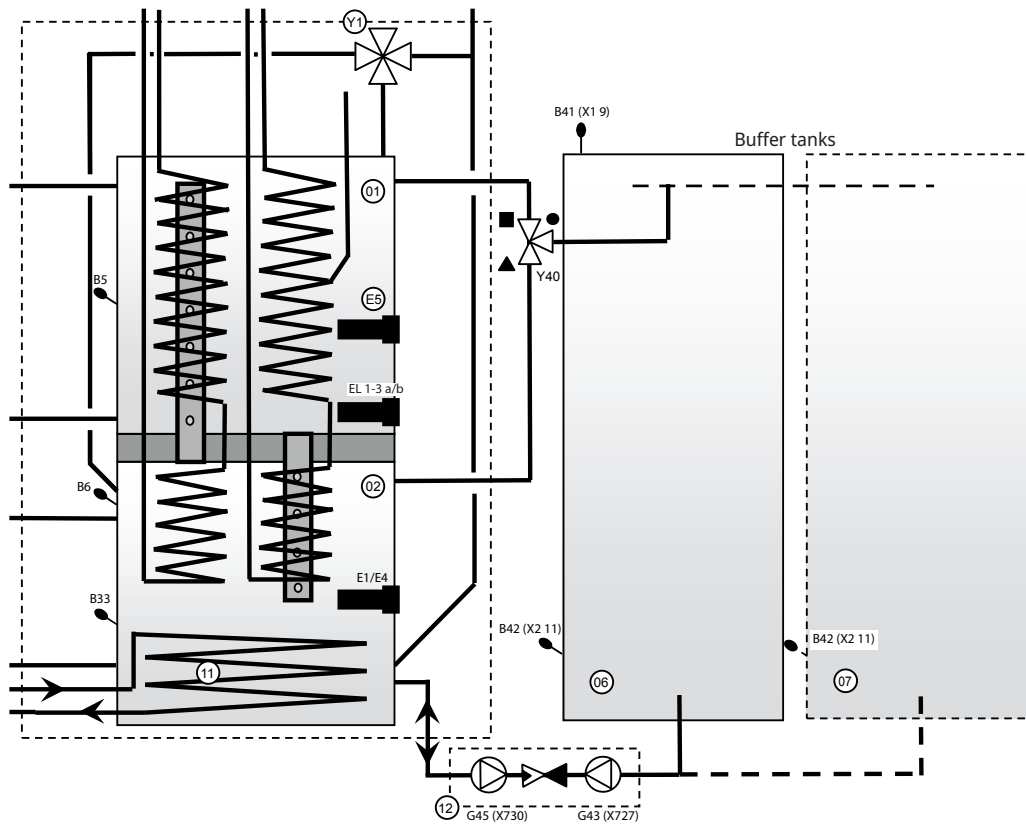

19.7 Additional boiler

When connecting an additional boiler (oil, pellets, electricity or gas), it must be connected to the CTC EcoZenith's upper tank connections. Circulation is undertaken by the pump (G44), which is controlled by the CTC EcoZenith. The sensor (B17) senses the boiler temperature in the external boiler.

Also refer to the "External boiler" section in the "Detailed Menu Descriptions" chapter (Advanced/Settings/External Boiler).

For electrical connections, refer to the "Electrical Installation" and "Installation of External Boiler" chapters.

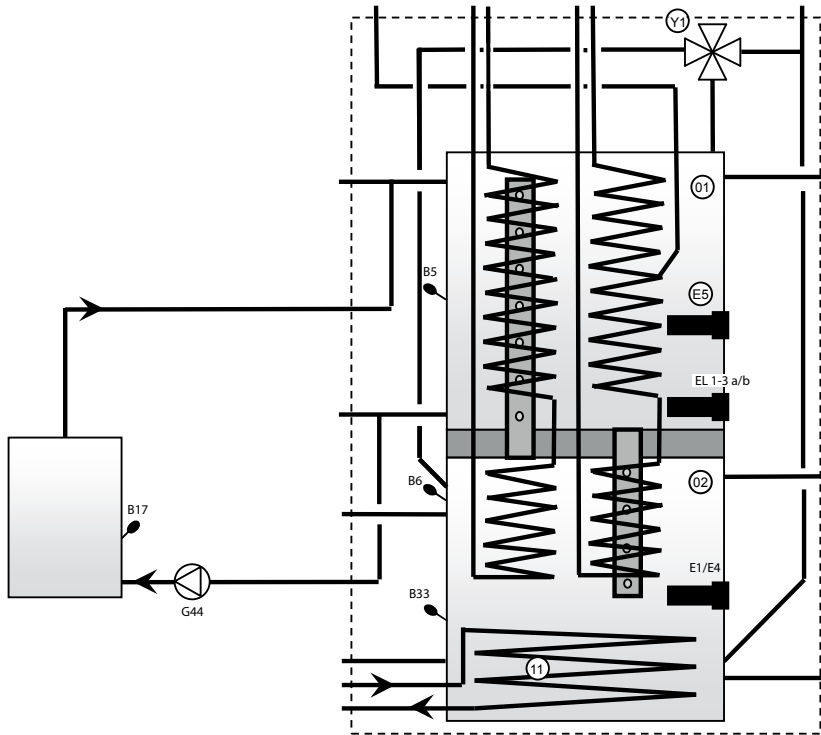

NB: Connecting with charge group reduces the potential risk of condensation forming and corrosion in the hearth.

19.8 Pool

A pool is connected to the CTC EcoZenith's lower tank. This means that the pool is heated by the same energy source as the heating circuit prioritises, for example, heat pump or solar panel. One pump (G50/G51, at the top of the drawing) circulates radiator water from the upper connection on the CTC EcoZenith's lower tank (02) to the pool heat exchanger (14), on to the heating circuit's return pipe and back to the CTC EcoZenith's lower tank. One pump (G50/G51, the lower one in the drawing) circulates pool water between the heat exchanger (14) and the pool (15). The sensor (B50) senses the pool temperature and starts the circulation pumps at the setpoint.

Also refer to the "Pool" section in the "Detailed Menu Descriptions" chapter (Advanced/Settings/Pool).

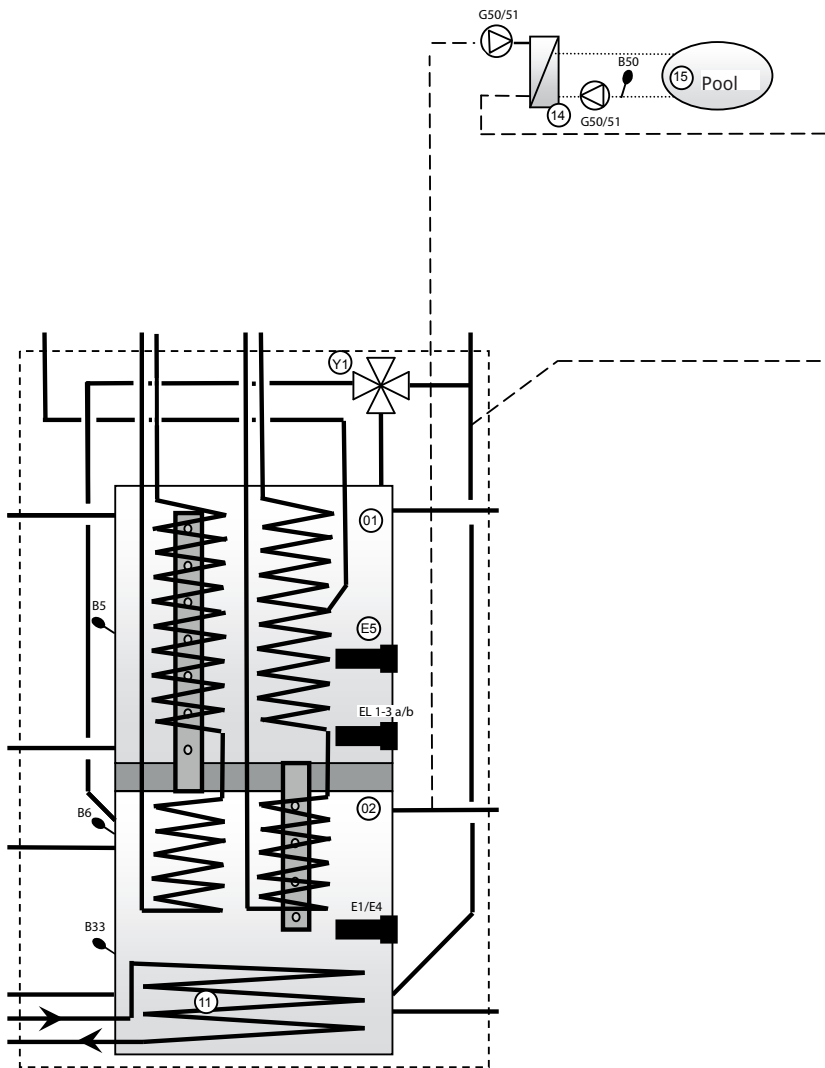

19.9 CTC EcoZenith – CTC EcoComfort (Cooling)

CTC EcoComfort is an accessory which utilises the cool temperatures of the borehole to create a cool indoor climate in summer. By connecting CTC EcoComfort to the separate fan convectors, its water is cooled using the borehole's cooler collector water. The heat in the house is supplied to the borehole in the bedrock.

CTC EcoComfort comes supplied pre-connected from the factory and is easy to connect to the system.

The cooling function is controlled entirely from your CTC EcoZenith where you can also perform your own settings as to when and how you want cooling to take place.

See also "Cooling" Menu in the "Detail menu description" chapter ("Advanced/Define system/Passive Cooling").

This type of cooling function is energy efficient, as only circulation pumps circulate the cool water. The capacity is however slightly lower compared to what is known as active cooling where the compressor, which requires more energy, is operated to generate cooling.

The system can be connected to separate fan convectors.

If separate fan convectors are connected, provided the system is insulated against condensation and there is a condensate collector in the fan convectors, much lower temperatures may be permitted.

See CTC EcoComfort manual for more information.

20. Electrical installation

This chapter describes how the various electrical components are connected in line with the designations reproduced in schematic diagrams and wiring diagrams.

Installation and connection in the CTC EcoZenith must be undertaken by an authorised electrician. All wiring must be installed according to applicable regulations. The CTC EcoZenith is factory set to (3 + 6) + (3 + 6) kW power output.

An additional 9 kW immersion heater is available as an accessory. Electrical connections are made behind the product's front panel. Loosen the screws on the front (4 screws), open and move the front aside (disconnect any network cables on the front display for easier access). The terminal blocks and the earth, neutral and phase terminals are located on the relay board. Insert the connection cables through the cable ducts on the product's top cover, which exit at the same height as the electric panel's top edge.

It is important to keep heavy current and extra low voltage cables apart in order to avoid interference problems; this applies outside the product also.

- Heavy current power cables must be routed in the cable duct in the insulation on the top of the unit and on the right side of the unit in the space between the side insulation and the top insulation (marked with broken lines).
- Extra low voltage cables are to be routed on the left side of the unit in the space between the side insulation and the top insulation (marked by a dotted line).

For higher currents and thicker cables, replace the blanking plug (see drawing) with an appropriate cable gland with strain relief.

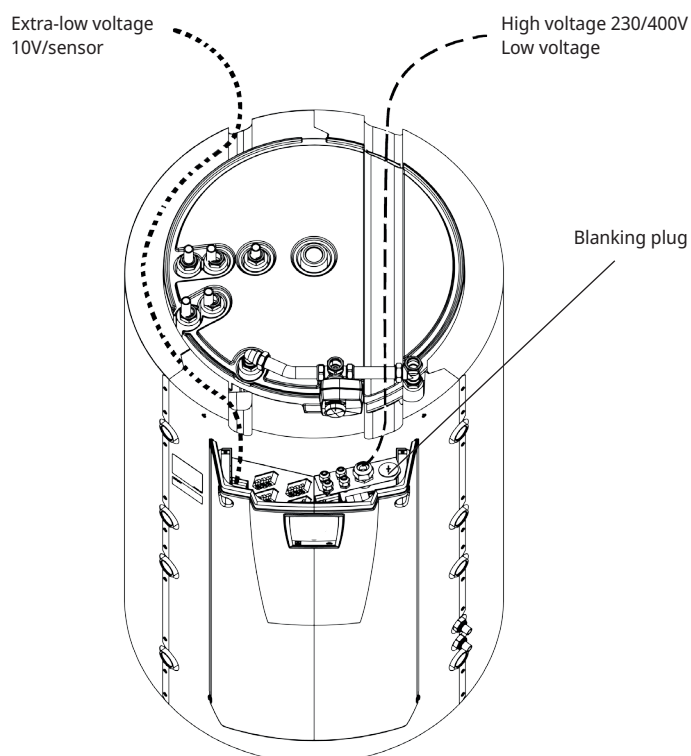

! It is important to keep high voltage and extra-low voltage cables apart in order to avoid interference problems; this applies outside the product also.

20.1 Positioning of electrical components

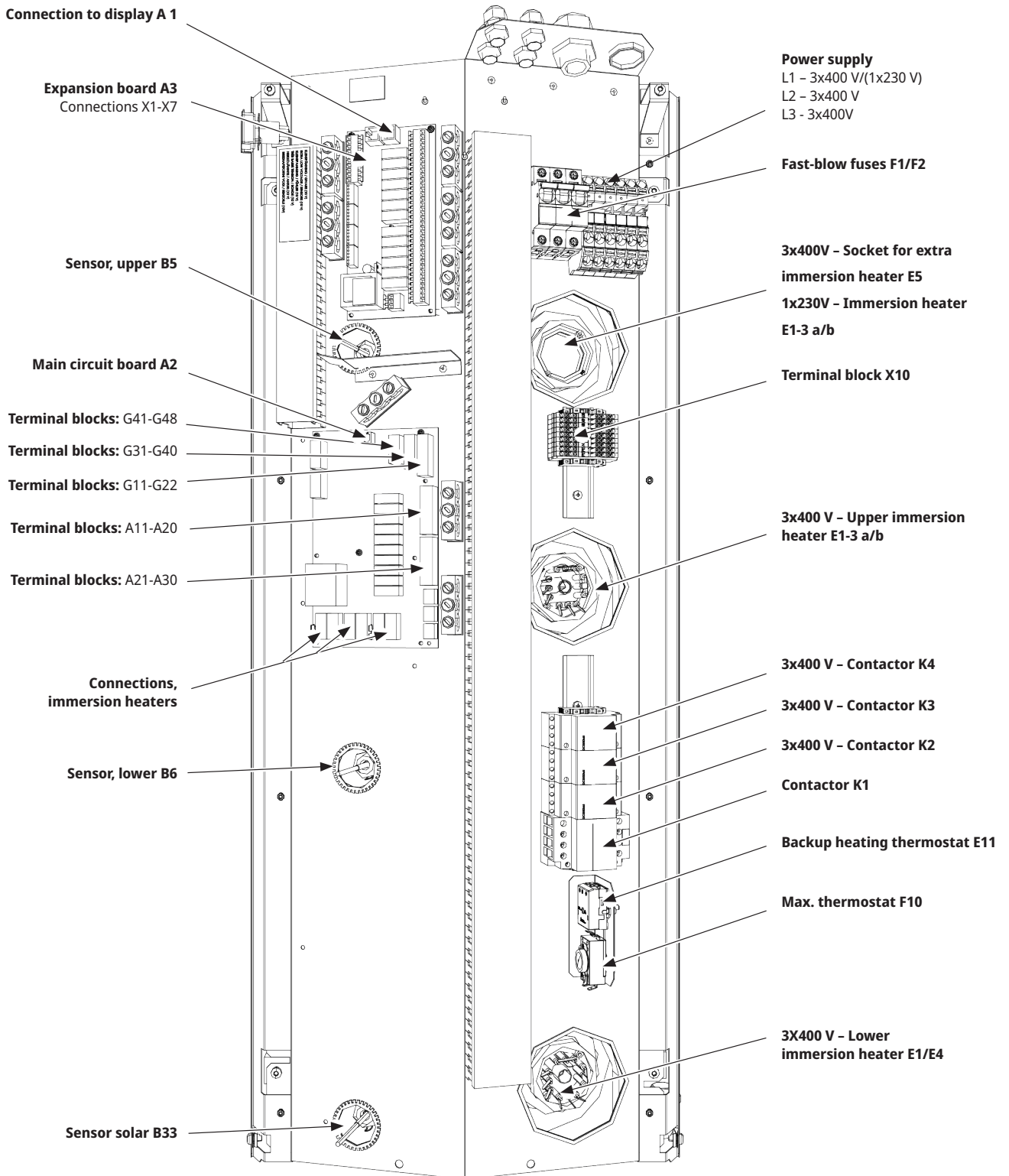

20.2 Omnipolar safety switch

The installation should be preceded by an omnipolar safety switch according to overvoltage category III, which ensures disconnection from all electric power sources.

20.3 Heat pump power supply



NB: The heat pump is powered separately. Not by CTC EcoZenith i555 Pro.

20.4 Communication between the CTC EcoZenith and CTC EcoAir/CTC EcoPart

The communication cable used is an LiYCY (TP) which is 4-core shielded cable, where the communication-bearing cores are of twisted pair type. This should be installed between the terminal blocks in the CTC EcoZenith: G51 (Brown), G52 (White), G53 (Green) and heat pump 1, from which the other heat pumps can be connected in series.

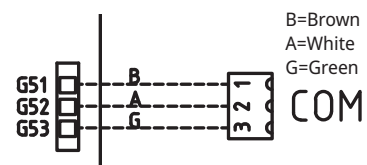

Close-up from wiring diagram.

20.5 Low voltage 230 V/400 V (High voltage)

Supply

400V 3N ~ 50 Hz and protective earth.

The size of the group fuse is given in Technical data in the section for the property owner.

Connects to terminal blocks marked L1, L2, L3, N, PE.

Max. thermostat

If the product has been stored in extremely cold conditions, the max. thermostat may have tripped; it can be reset by pressing the button on the electrical cabinet behind the front panel. Always check that the max. thermostat has not tripped before installation.



Max. thermostat symbol.

Alarm 1-pole alternating relay (Output for alarm to an external unit)

230V 1N ~

Connects to the circuit board:

ALARM

NC

NO

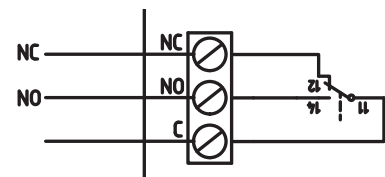

(G1) Circulation pump, heating circuit 1

230V 1N ~

Connected on the circuit board/block:

Phase:	pole A31
Neutral:	pole A33
Earth:	pole PE

Check that the pump is correctly connected by test running it in the "Advanced/Service/Function Test" menu in the control system.

(G2) Circulation pump, heating circuit 2

230V 1N ~

Connected on the circuit board/block:

Phase:	pole A36
Neutral:	pole A34
Earth:	pole PE

Check that the pump is correctly connected by test running it in the "Advanced/Service/Function Test" menu in the control system.

(G3) Circulation pump, heating circuit 3/ Or: circulation pump for CTC EcoComfort (passive cooling), accessory

230V 1N ~

Connected to the expansion board X6/terminal block:

Phase:	X6 pole 15
Zero:	X6 pole 17
Earth:	X6 pole 16

Check that the pump is correctly connected by test running it in the "Advanced/Service/Function Test" menu in the control system.

(G6) Circulation pump, flue gas controlled

230V 1N ~

Connected to the expansion board X7/terminal block:

Phase:	X7 pole 21
Zero:	X7 pole 23
Earth:	X7 pole 22

Check that the pump is correctly connected by test running it in the "Advanced/Service/Function Test" menu in the control system.

(G11, G12, G13) Charge pumps, HP1, HP2 and HP3

230V 1N~

The charge pumps can be controlled by the CTC EcoZenith.

The charge pumps can be connected to the relay board/terminal block:

(G11) Charge pump 1

WILO Stratos Para

GRUNDFOS UPM GEO 25-85

Relay output 8 A		A12
PWM+:	brown	G46
GND:	blue	G45

(G12) Charge pump 2

WILO Stratos Para

GRUNDFOS UPM GEO 25-85

Powered separately		
PWM+:	brown	G48
GND:	blue	G47

(G13) Charge pump 3

WILO Stratos Para

GRUNDFOS UPM GEO 25-85

Powered separately		
PWM+:	brown	G75
GND:	blue	G76

Check that the pump is correctly connected by test running it in the "Advanced/Service/Function Test" menu in the control system.

(G30, G32) Solar pumps

The solar PWM pumps (G30 and G32) of model WILO Stratos PARA differ from the other PWM pumps. If the PWM control signal is interrupted, the solar pumps stop, whereas the other PWM pumps work at 100% power if the signal is interrupted.

(G30) Circulation pump solar collector - Wilo Stratos Para

230V 1N~

The circulation pump is connected to the following terminal blocks:

(G30) Circulation pump, expansion board X5:

Note the cable colours!

PWM+:	white	X5 pole 1
GND:	brown	X5 pole 2



Check the function by test running the pump in the "Advanced/Service/Function Test" menu in the control system.

(G30) Circulation pump solar collector - Grundfos UPM3 Solar

230V 1N~

The circulation pump is connected to the following terminal blocks:

(G30) Circulation pump, expansion board X5:

Note the cable colours!

PWM+:	brown	X5 pole 1
GND:	blue	X5 pole 2



Check the function by test running the pump in the "Advanced/Service/Function Test" menu in the control system.



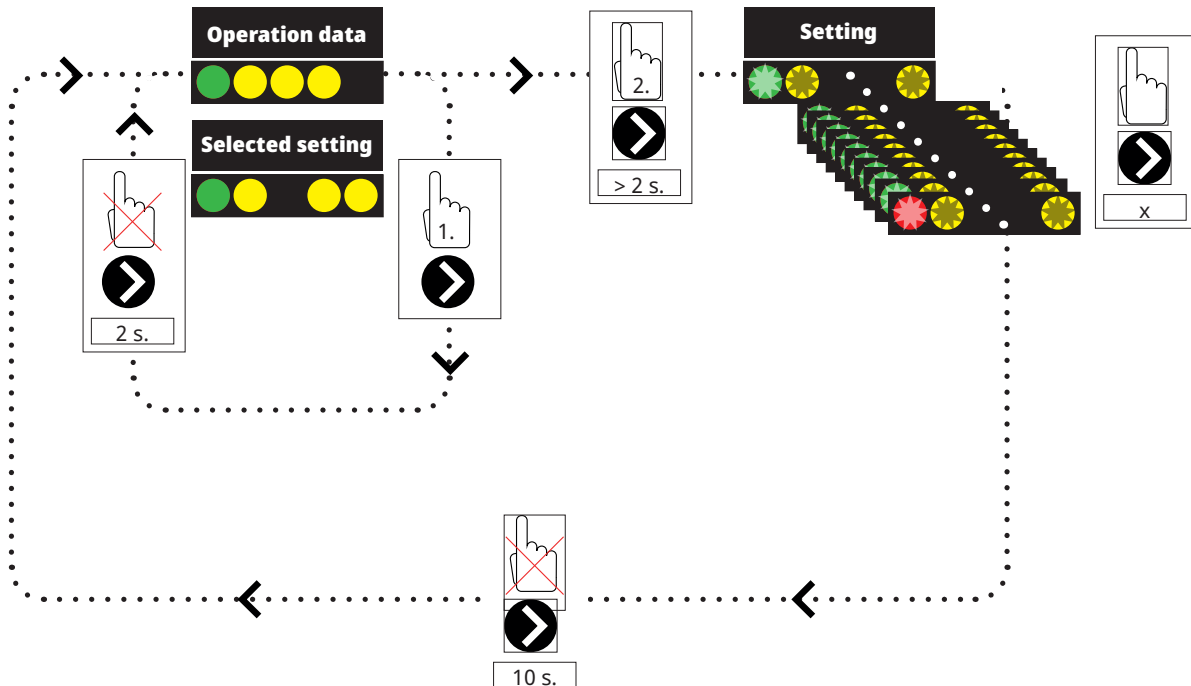

The pump must be set to PWM Cprofile (default)



















1. Briefly press the circulation pump arrow to show the operating mode to which the pump is set. After 2 seconds, the operational information screen will be displayed again.

2. Pressing the circulation pump arrow for 2 seconds will cause the LEDs to flash and the mode setting can then be changed. Press repeatedly until the desired mode flashes. After 10 seconds, the operational information screen will be displayed again.



Operation data:

	Standby (flashing)
	0% - P1 - 25%
	25% - P2 - 50%
	50% - P3 - 75%
	75% - P4 - 100%

Selecting mode setting

Control Mode	Mode	xx-75	xx-105	xx-145	LEDs
Constant Curve		4.5 m	4.5 m	6.5 m	
Constant Curve		4.5 m	5.5 m	8.5 m	
Constant Curve		6.5 m	8.5 m	10.5 m	
Constant Curve		7.5 m	10.5 m	14.5 m	
Control Mode	Mode	xx-75	xx-105	xx-145	LEDs
PWM C Profile					
PWM C Profile					
PWM C Profile					
PWM C Profile					

Alarm info:

	Blocked
	Supply voltage low
	Electrical error

(G32) Circulation pump, plate heat exchanger, solar heating, Wilo Stratos Para

230V 1N~

The heat exchanger pump is connected to the following terminal blocks:

(G32) Pump, expansion board X5:

Note the cable colours!

PWM+:	white	X5 pole 3
GND:	brown	X5 pole 4

Check the function by test running the pump in the "Advanced/Service/Function Test" menu in the control system.



Solar recharge borehole, charge pump (G31)

230V 1N~

Phase:	X6 pole 8
Zero:	X6 pole 11
Earth	X6 pole 10

Pole 8 is connected to an external connection box which distributes voltage to the solar 3-way valve (Y31) and the Recharge borehole charge pump (G31). Refer to the wiring diagram.

Check the function by test running the pump in the "Advanced/Service/Function Test" menu in the control system.

Solar recharge borehole, 3-way valve solar (Y31)

230V 1N~

NB! It is important to connect the phase voltage to L (pole 9); refer to the wiring diagram.

The 3-way valve is connected to the following terminal blocks:

(Y31) 3-way valve, expansion board X6:

Relay output 8 A:	Open to borehole	X6 pole 8	also controls Charge pump – recharging borehole (G31)
Phase:	Open Tank	X6 pole 9	
Zero:		X6 pole 11	

Valve 582581001 (see image) must only be connected with relay output, X6 pole 8 and neutral, X6 pole 11.

Pole 8 is connected to an external connection box which distributes voltage to the solar 3-way valve (Y31) and the Recharge borehole charge pump (G31). Refer to the wiring diagram.

Check the function by test running the valve in the "Advanced/Service/Function Test" menu in the control system.

582581001 22 3/4"



(G40) Circulation pump for DHW

230V 1N~

The circulation pump is connected to the following terminal blocks: (G40)
Circulation pump, expansion board X6:

Phase:	X6 pole 1
Zero:	X6 pole 3
Earth:	X6 pole 2

Check that the pump is correctly connected by test running it in the "Advanced/Service/Function Test" menu in the control system.

(G41) Circulation pump external DHW tank

230V 1N~

The pump is connected to the following terminal blocks:
(G41) Charge pump, expansion board (X7):

Phase:	X7 pole 19
Zero:	X7 pole 20
Earth:	X7 pole 22

Check that the pump is correctly connected by test running it in the "Advanced/Service/Function Test" menu in the control system.

(G43) Circulation pump, external buffer tank charging

230V 1N~

The circulation pump is connected to the following terminal blocks: (G43)
circulation pump, extension board X7:

Phase:	X7 pole 27
Zero:	X7 pole 29
Earth:	X7 pole 28

Check that the pump is correctly connected by test running it in the "Advanced/Service/Function Test" menu in the control system.

(G45) Circulation pump, external buffer tank discharging

230V 1N~

The circulation pump is connected to the following terminal blocks: (G43)
circulation pump, extension board X7:

Phase:	X7 pole 30
Zero:	X7 pole 32
Earth:	X7 pole 31

Check that the pump is correctly connected by test running it in the "Advanced/Service/Function Test" menu in the control system.

(G44) Circulation pump, external boiler

230V 1N~

The circulation pump is connected to the following terminal blocks: (G44)
Circulation pump, expansion board X7:

Zero:	X7 pole 26
Relay output	X7 pole 24

Check that the pump is correctly connected by test running it in the "Advanced/Service/Function Test" menu in the control system.

(G50) and (G51) Circulation pumps, pool

230V 1N~

Both pumps (G50) & (G51) are connected to the following terminal blocks:

Pumps pool (G50) and (G51), expansion board X7:

Phase:	pole 33
Neutral:	pole 35
Earth:	pole 34

Pole 33 is connected to an external connection box which distributes voltage to the charge pump (G50) and circulation pump (G51).

Check the function by test running the pump in the "Advanced/Service/Function Test" menu in the control system.

(Y1) Mixing valve, bivalent, heating circuit 1

230V 1N ~.

1.5 m cable 1.5 mm², neutral, open, close.

Connected on the circuit board/block:

Black cable	Open:	pole A27
Brown cable	Close:	pole A28
Blue cable	Zero:	pole A29
Red cable	Limit position:	pole A22
White cable	Limit position:	pole A21

Check that the open and close signals are correctly connected by testing the motor in the "Advanced/Service/Function Test" menu in the control system.

(Y2, Y3) Mixing valves, heating circuits 2-3.

(Y3) Optional mixing valve for CTC EcoComfort (cooling).

230V 1N~

1.5 m cable 1.5 mm², neutral, open, close.

The mixing valve motors are connected to the PCB/terminal block:

(Y2) Mixing valve 2

Open:	pole A15
Close:	pole A16
Neutral:	pole A17

(Y3) Mixing valve 3/Or Mixing valve 2 in CTC EcoComfort

Expansion board X6

Open:	X6 pole 12
Close:	X6 pole 13
Zero:	X6 pole 14

Check that the open and close signals are correctly connected by testing the motor in the "Advanced/Service/Function Test" menu in the control system.

(Y21) 3-way valves, DHW

230V 1N~
2.5 m cable 1.5 mm²

When relay output A18 is powered, the flow is to the upper tank for DHW charging. When it is not powered, the flow is to the lower tank.

The 3-way valves are connected to the following terminal blocks:

(Y21) 3-way valves, DHW

Relay output (black):	pole A18
Phase (brown):	pole A19
Neutral (blue):	pole A20

Check the function by test running the 3-way valve in the "Advanced/Service/Function test" menu in the control system.

In the "DOWN" position on the function menu, port ▲ should be open (turn the knob on the motor clockwise, CW). In the "UP" position, port ■ should be open (turn the knob on the motor counterclockwise, CCW). The motor is fitted to the 3-way valve by a screw. To unfasten the motor: remove the knob by pulling it off, unfasten the screw and remove the motor.

To prevent faults, turn the actuator and 3-way valve to the starting position for fitting as shown in the figures. Pull out the knob on the actuator and turn to the central position.

Port ● should be completely open; ports ■ and ▲ should be partially open. Ensure that the groove in the white shaft coupling is in position as shown in the figure. The 3-way valve and actuator can then be fitted together as shown in the figure or turned in 90-degree steps relative to each other.

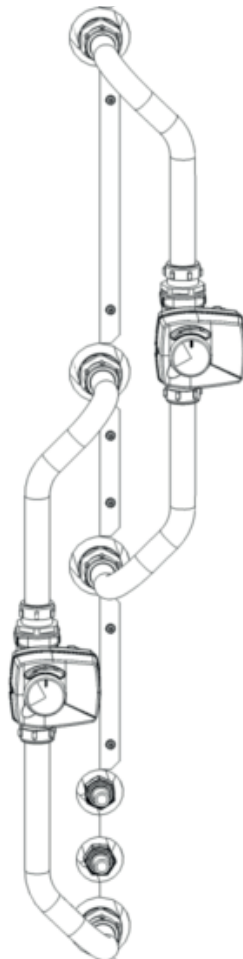
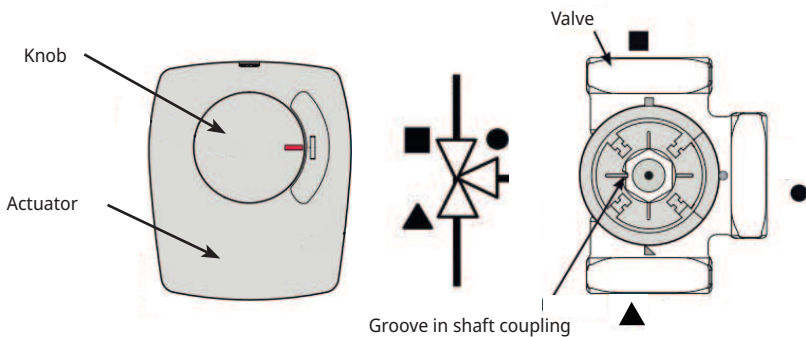

If ports ▲ and ■ have been shifted during the hydraulics connection, the motor can be reconnected to change its direction of rotation. This is done using two jumpers inside the motor. **NOTE! The direction of rotation cannot be changed by swapping the black and brown cables.**

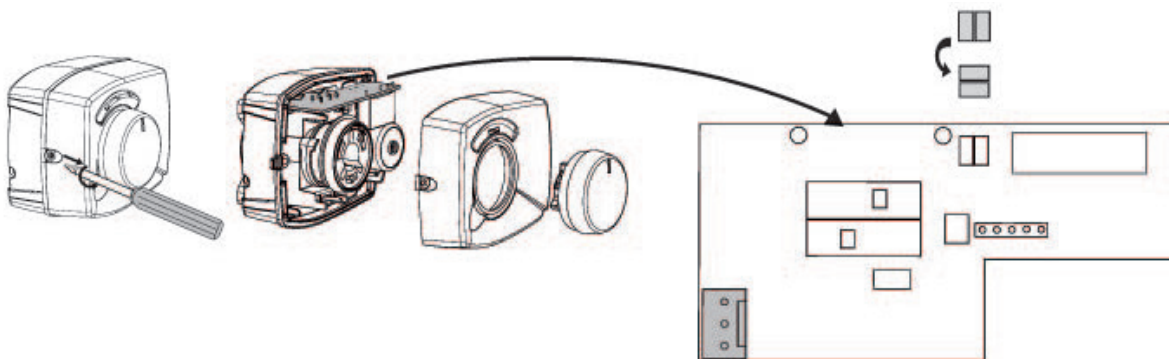

(Y40) 3-way valve external buffer tank

230V 1N~.

2.5 m cable 1.5 mm²

The 3-way valve is connected to the following terminal blocks: (Y40) 3-way valve, extension board X6:

(Y40) 3-way valve, charging/discharging buffer tank

Relay output (black):	X6 pole 4
Phase (brown):	X6 pole 5
Neutral (blue):	X6 pole 7

Check the function by test running the 3-way valve in the "Advanced/Service/Function test" menu in the control system.

In the "DOWN" position on the function menu, port ▲ should be open (turn the knob on the motor clockwise, CW). In the "UP" position, port ■ should be open (turn the knob on the motor counterclockwise, CCW).

The motor is fitted to the 3-way valve by a screw. To unfasten the motor: remove the knob by pulling it off, unfasten the screw and remove the motor.

To prevent faults, turn the actuator and 3-way valve to the starting position for fitting as shown in the figures. Pull out the knob on the actuator and turn to the central position.

Port ● should be completely open; ports ■ and ▲ should be partially open. Ensure that the groove in the white shaft coupling is in position as shown in the figure. The 3-way valve and actuator can then be fitted together as shown in the figure or turned in 90-degree steps relative to each other.

If ports ▲ and ■ have been shifted during the hydraulics connection, the motor can be reconnected to change its direction of rotation. This is done using two jumpers inside the motor.

NOTE: the direction of rotation cannot be changed by swapping the black and brown cables.

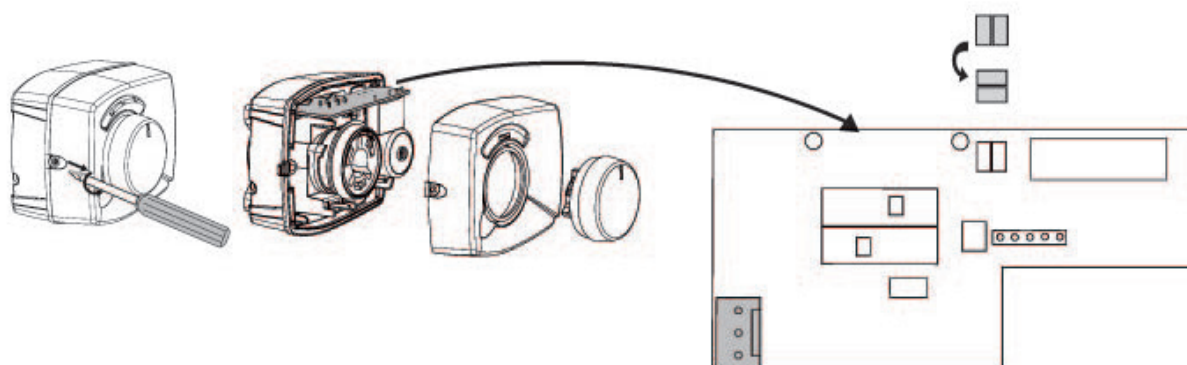
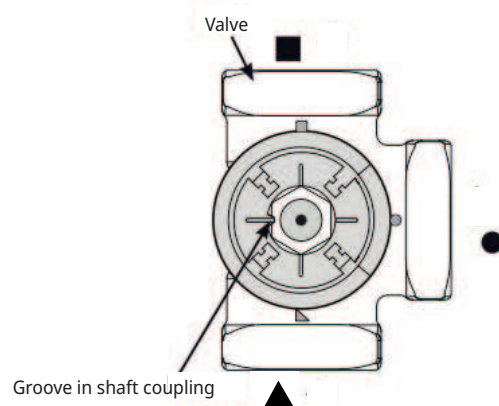
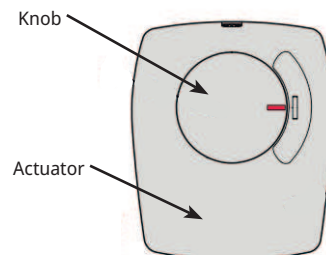

20.6 Sensor (Safety Extra-Low Voltage (SELV))

The sensors that form part of each system solution must be fitted to the relay board/terminal block as follows: All sensors are temperature sensors.

Room sensors (B11, B12, B13)

(B13) Optional room sensor for CTC EcoComfort (Cooling).

Room sensors should be installed at head height in open areas of the property with good air flow and where a representative temperature can be expected (not close to sources of heat or cold). If you are unsure of where to place a sensor, hang it by a loose cable and test different positions.

Connection: 3-core cable, min 0.5 mm², between sensor and control box. The cables are connected as shown in the table above.

On start-up, an alarm is given if the sensor is incorrectly connected. Test the alarm LED by testing the function in the "Advanced/Service/Function Test" menu.

In the control system you can select whether or not to have the room sensor operational. If the room sensor is deselected, the heating level is controlled by the outdoor sensor/primary flow sensor. The alarm lamp on the room sensor still functions as normal. A room sensor does not, however, need to be installed if the function is deselected.

Room sensor cable connection:

(B11) Room sensor 1

block no.	G17	alarm output
block no.	G18	GND
block no.	G19	input

(B12) Room sensor 2

Or room sensor for CTC EcoComfort (passive cooling), accessory

block no.	G20	alarm output
block no.	G21	GND
block no.	G22	input

(B13) Room sensor 3, expansion board X4

block no.	19	alarm output
block no.	20	input
block no.	21	GND

Outdoor sensor (B15)

The outdoor sensor should be fitted to the outer wall of the house, preferably in a north-northeastern or north-northwestern direction. The sensor should be placed out of direct sunlight. However, where this is difficult to achieve it can also be shielded from the sun by a screen. Remember that the sun rises and sets at different points at different times of the year.

The sensor should be placed about three-quarters of the way up the wall so that it senses the correct outdoor temperature and so that it is not affected by a heat source such as a window, infra-heating, air ventilation outlet, etc.

Connection: 2-core cable (min 0.5 mm²) between the sensor and control box.

The sensor is connected to terminal blocks G11 and G12 of the control module. Connect to the outdoor sensor at the arrows.

NB: Strip the wire ends and fold them double if light cable is used. It is important that the contact in the connections is good.

20.6.1 Sensor connection

Mount the sensor on the pipe. The sensing part is towards the end of the sensor.

- Attach the sensor using the cable tie provided.
- Ensure that the sensor makes good contact with the pipe.
- NB: Apply contact paste to the end part of the sensor between the sensor and the pipe to ensure good contact.
- NB: Insulate the sensor using pipe insulation, for example. This prevents the measurement from being affected by the ambient temperature.
- Connect the cables to the CTC EcoZenith connection block. If the cables are too short, join extra length to them.

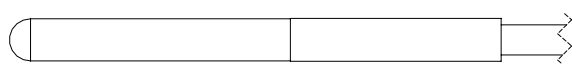
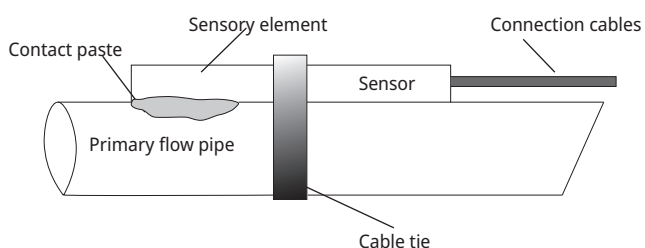

Sensor NTC 22k, white cable

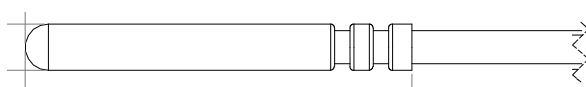

Solar sensor PT1000, grey or red cable

i Insulate the sensor using pipe insulation, for example. Do not attach the sensor cable permanently until you have tested where the best location is.

Primary flow sensor (B1, B2, B3). (B3) Or primary flow sensor for CTC EcoComfort (passive cooling)

The sensors sense the outgoing temperature to the radiators.

Secure the primary flow sensor to the pipe using straps or similar. Most important is the position of the tip of the sensor as this is the part that detects the temperature. The sensor must be insulated to prevent the ambient temperature from affecting the measurement. For optimum function, use contact paste.

(B1) Sensor, primary flow to heating circuit 1

Position: on the primary flow to heating circuit 1.
The sensor is connected to the relay board in positions G13 and G14.
Sensor type: NTC 22k

(B2) Sensor, primary flow to heating circuit 2

Position: on the primary flow to heating circuit 2 after radiator pump G2.
For passive cooling, on the primary flow to.
The sensor is connected to the relay board in positions G15 and G16.
Sensor type: NTC 22k

(B3) Sensor, primary flow to heating circuit 3 Optional primary flow sensor for CTC EcoComfort (cooling), accessory.

Position: on the primary flow to heating circuit 3 after radiator pump G3.
The sensor is connected to expansion board X3 in positions 13 and 14.
Sensor type: NTC 22k

Other sensors

(B5) Sensor, upper tank(factory fitted)

Placement: in the tank's uppermost sensor pipe.
The sensor is connected to the relay board in positions G63 and G64.
Sensor type: NTC 22k

(B6) Sensor, lower tank(factory fitted)

Placement: in the tank's middle sensor pipe.
The sensor is connected to the relay board in positions G65 and G66.
Sensor type: NTC 22k

(B7) Return sensor heating circuit

Position: on the return pipe from the heating circuit.
The sensor is connected to the relay board in positions G31 and G32.
Sensor type: NTC 22k

(B8) Flue gas sensor

Position: in a sensor pipe or on the flue gas jacket surface on the wood boiler.
The sensor is connected to the relay board in positions G35 and G36.
Sensor type: NTC 3.3k

(B9) Sensor, wood boiler

Position: in a sensor pipe or jacket surface on the wood boiler.
The sensor is connected to the relay board in positions G61 and G62.
Sensor type: NTC 22k

(B17) Sensor external boiler

Position: in a sensor pipe or jacket surface on the boiler.
The sensor is connected to the relay board in positions G71 and G72.
Sensor type: NTC 22k

(B30) Sensor in to solar panels

Position: on the return pipe into the solar panels.
The sensor is connected to expansion board X1 in positions 3 and 4.
Sensor type: PT1000

(B31) Sensor, primary flow solar collector

Position: on the pipe out from the solar collectors, as close to the solar collector as possible, or in a sensor pipe or similar in the solar collector.
The sensor is connected to expansion board X1 at positions 1 and 2.
Sensor type: PT1000, red cable (>150°C)

((B33) Sensor, solar coil (factory fitted))

Placement: in the tank's lowest sensor pipe.
The sensor is connected to the circuit board in positions G67 and G68.
Sensor type: NTC 22k

(B41) Sensor, external buffer tank upper

Position: in the sensor pipe or jacket surface on the upper part of the tank.
The sensor is connected to the circuit board in positions X3 9 and X3 10.
Sensor type: NTC 22k

(B42) Sensor, external buffer tank lower

Position: in the sensor pipe or jacket surface on the lower part of the tank.
The sensor is connected to the circuit board in positions X3 11 and X3 12.
Sensor type: NTC 22k

(B43) Sensor, external DHW tank

Position: in the sensor pipe or jacket surface on the external DHW tank.
The sensor is connected to the circuit board in positions X2 7 and X2 8.
Sensor type: NTC 22k

(B50) Sensor, pool

Position: on the return pipe between the pool pump and pool.
The sensor is connected to expansion board X3 in positions 15 and 16.
Sensor type: NTC 22k

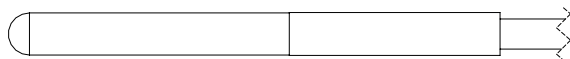

Sensor NTC 22k, white cable



Solar sensor PT1000, grey or red cable

20.7 Current sensor connection

The three current sensors, one for each phase, are fitted on the fuse panel in the following manner:

Each phase from the electricity distribution board supplying the product is channelled through a current sensor before termination at the relevant terminal. Then connect to the boiler based on the terminal board diagram. This allows the phase current to be sensed all the time and compared with the value set for the heat pump's load switch. If the current is higher, the control unit drops to a lower heat output. If it is still too high, further reduction in output takes place. When the current has dropped below the set value again, the output will increase.

This means that the current sensors, along with the electronics, prevent more power being supplied than the main fuses can tolerate. The current sensors' holes for cables are 11 mm in diameter.

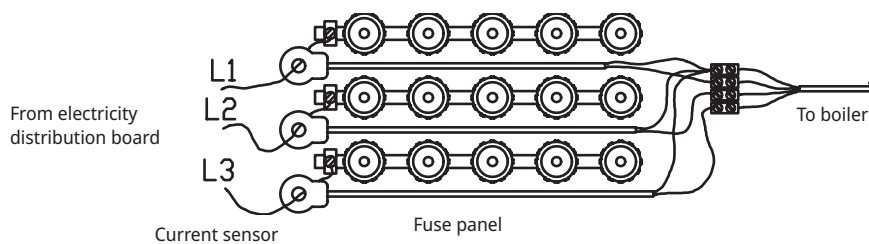

20.8 Settings to be carried out by the installation electrician

The following settings shall be made by the installation electrician after installation:

- Select main fuse size.
- Select effect limitation.
- Check room sensor connection.
- Check that the sensors connected indicate reasonable values.
- Carry out the following checks:

Check room sensor connection

1. Scroll down and select the LED Room Sensor option in the "Advanced/Service/Function Test/Heating Circuit" menu.
2. Select "On". Check that the room sensor LED lights up. If not, check the cables and connection.
3. Select "Off". If the LED goes off, the check is complete.

Checking connected sensors

If any sensor is incorrectly connected, a message will appear on the display, e.g. "Alarm sensor out". If several sensors are incorrectly connected, the different alarms are displayed on different rows. If no alarm is displayed, the sensors are connected correctly. Note the alarm function of the room sensor (LED) cannot be detected on the display. It must be checked on the room sensor. The current sensor connection has no alarm, but the current value can be read in the "Operation data" menu.

20.9 Installing a backup power supply

The DIP switch on the PCB is used to set the backup power supply. The DIP switch is marked "RESERV" (BACKUP).

When the switch is set to ON, the step is actively operating in backup heating mode.

3x400V

Switch	5	4	3	2	1
Phase	L3	L2	L2	L1	L1
Current	10 A	10 A	2.6 A	10 A	1.3 A
Output	1.2 kW	2.3 kW	0.6 kW	2.3 kW	0.3 kW

1x230V

Switch	-	4	3	2	1
Phase	-	L2	L2	L1	L1
Current	-	8.7 A	8.7 A	8.7 A	13 A
Output	-	2.0 kW	2.0 kW	2.0 kW	3.0 kW

3x230V

Switch	5	4	3	2	1
Phase	-	L2-L3	L2-L3	L1-L3	L1-L3
Current	-	9.3 A	5.6 A	9.3 A	5.6 A
Output	-	2.3 kW	1.2 kW	2.3 kW	1.2 kW

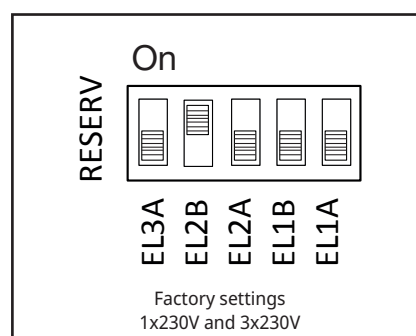
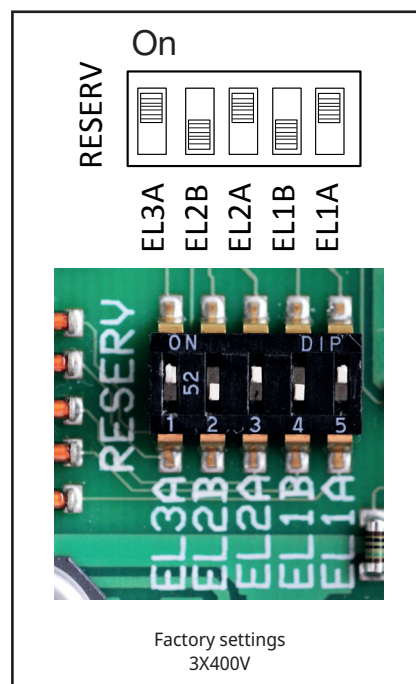

21. Installation of optional immersion heater

CTC EcoZenith i555 Pro has two 9 kW immersion heaters, both factory installed. A third 9 kW immersion heater can also be installed thus giving total installed heating power of 27 kW. The third immersion heater is a CTC accessory and is connected as follows:

1. Disconnect the electrical supply to the CTC EcoZenith.
2. Drain the CTC EcoZenith of water if required.
3. Remove the four screws holding the plastic front, two at the top and two at the bottom, and then remove the plastic front. Ensure that the display cable is disconnected before removing the front completely. The cable is disconnected by pressing in the pin on the connector and pulling the cable downwards.
4. Remove the 2" plug from where the upper immersion heater will be placed.
5. Install the immersion heater using a new, greased flat gasket. Recommended tightening torque – 220 Nm.
6. The cabling for the heater is coiled and strapped. Remove the strapping and connect the white cables marked 6 kW to the brown end cable sleeve on the immersion heater, and connect the black cables marked 3 kW to the black end cable sleeve on the heater.
7. Fill the CTC EcoZenith with water and ensure that there are no leaks.
8. Fit the front.
9. Switch on the electricity supply.
10. Define the immersion heater in the "Advanced/Define/Immersion heaters/Upper Immersion heater" menu.
11. Test the immersion heater connections in the "Advanced/Service/Function test/Test immersion heaters" menu.
12. Set immersion heater operation in the "Advanced/Settings/Immersion heaters" menu.
13. The upper immersion heater is now ready for use.

22. Installation of additional boiler

CTC EcoZenith i555 Pro is able to control either a third immersion heater or an external additional boiler. Under no circumstance may these be connected at the same time. To connect an additional boiler, CTC EcoZenith's electrical cabling must be rewired. Please note that all electrical reconnection and installation in the CTC EcoZenith must be performed by an authorised electrician. All wiring must be installed according to applicable provisions.

1. Disconnect the electrical supply to the CTC EcoZenith.
2. Make the hydraulic connections for the additional boiler and pump.
3. Remove the four screws holding the plastic front, two at the top and two at the bottom, and then remove the plastic front. Ensure that the display cable is disconnected before removing the front completely. The cable is disconnected by pressing in the pin on the connector and pulling the cable downwards.
4. Make the electrical connections for the pump and sensor as indicated in the wiring diagram.
5. Disconnect the cable from output X7. Make sure the cable cannot possibly come into contact with live parts and thereby cause a fault. The cable end must be provided with an end cap or similar anti-touch blanking, or else the cable can be completely removed.
6. Connect a relay for starting the additional boiler to output X7 18. Refer to the wiring diagram for details.
7. Fit the front.
8. Switch on the electricity supply.
9. Define the additional boiler in the "Advanced/External Boiler" menu.
10. The additional boiler is now ready for use.

23. Electrical diagram

23.1 Wiring diagram relay board 3x400V

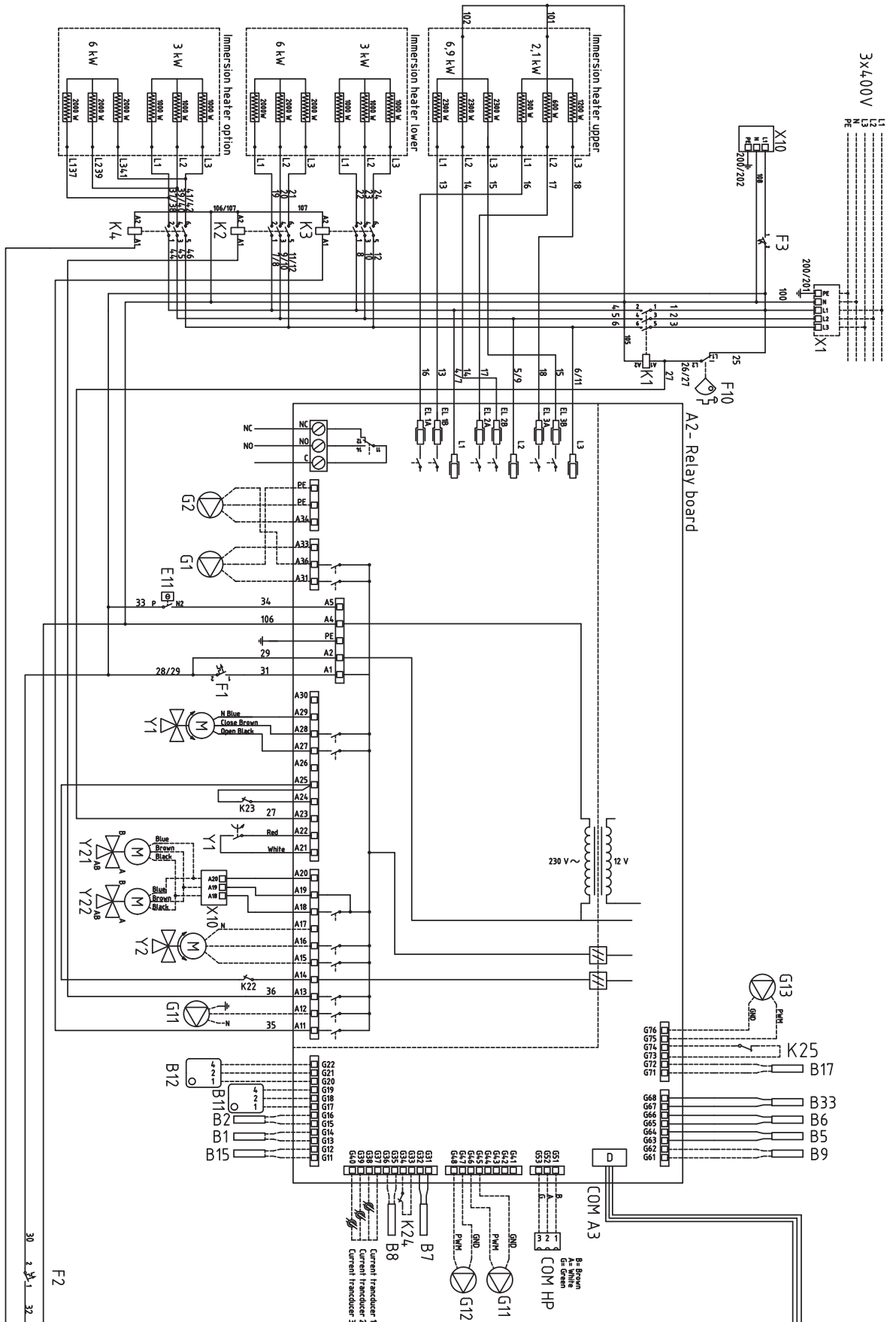
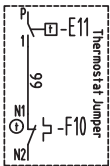

23.2 Wiring diagram relay board 1x230V

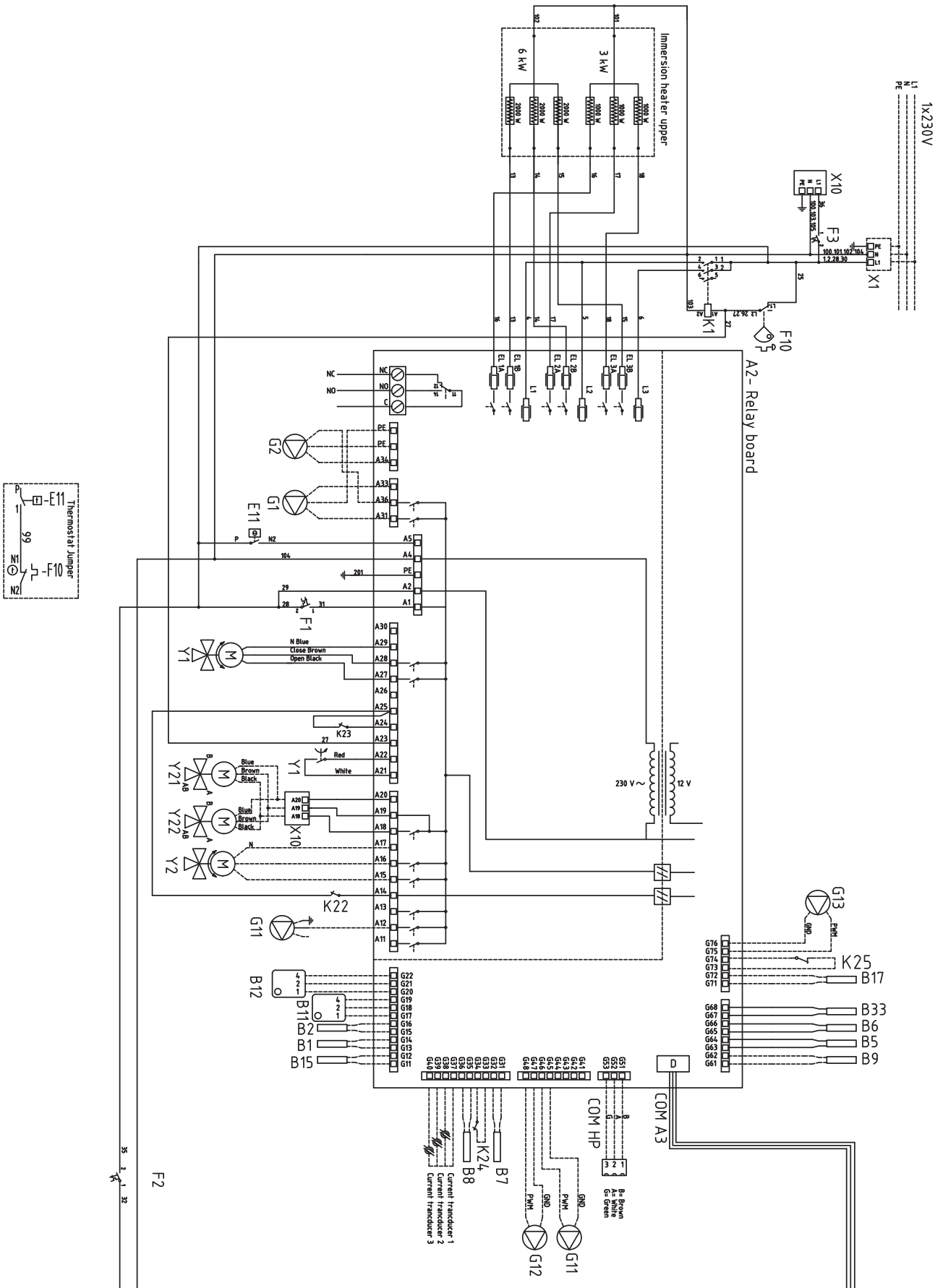

23.3 Wiring diagram relay board 3x230V

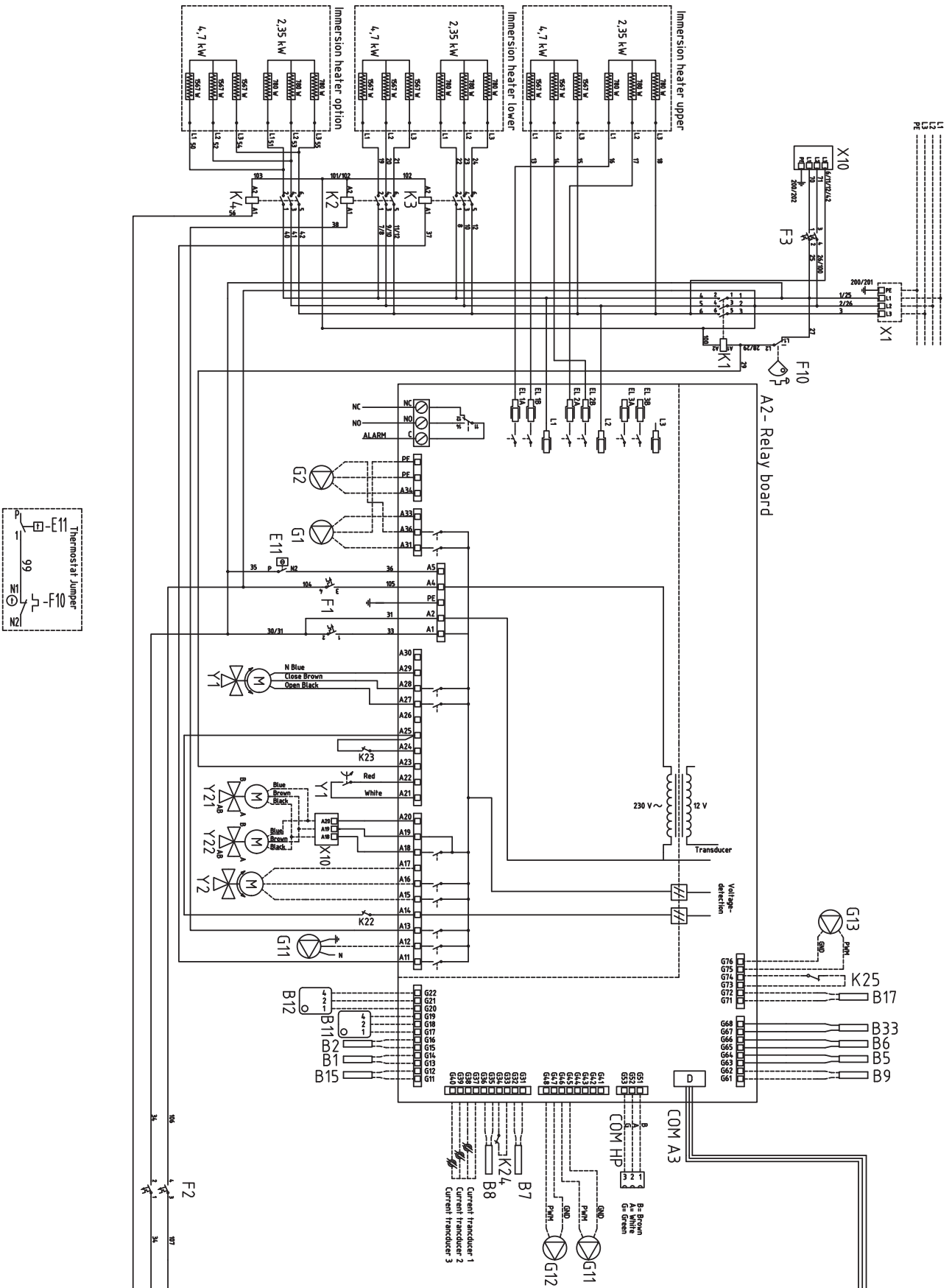

23.4 Wiring diagram for expansion board

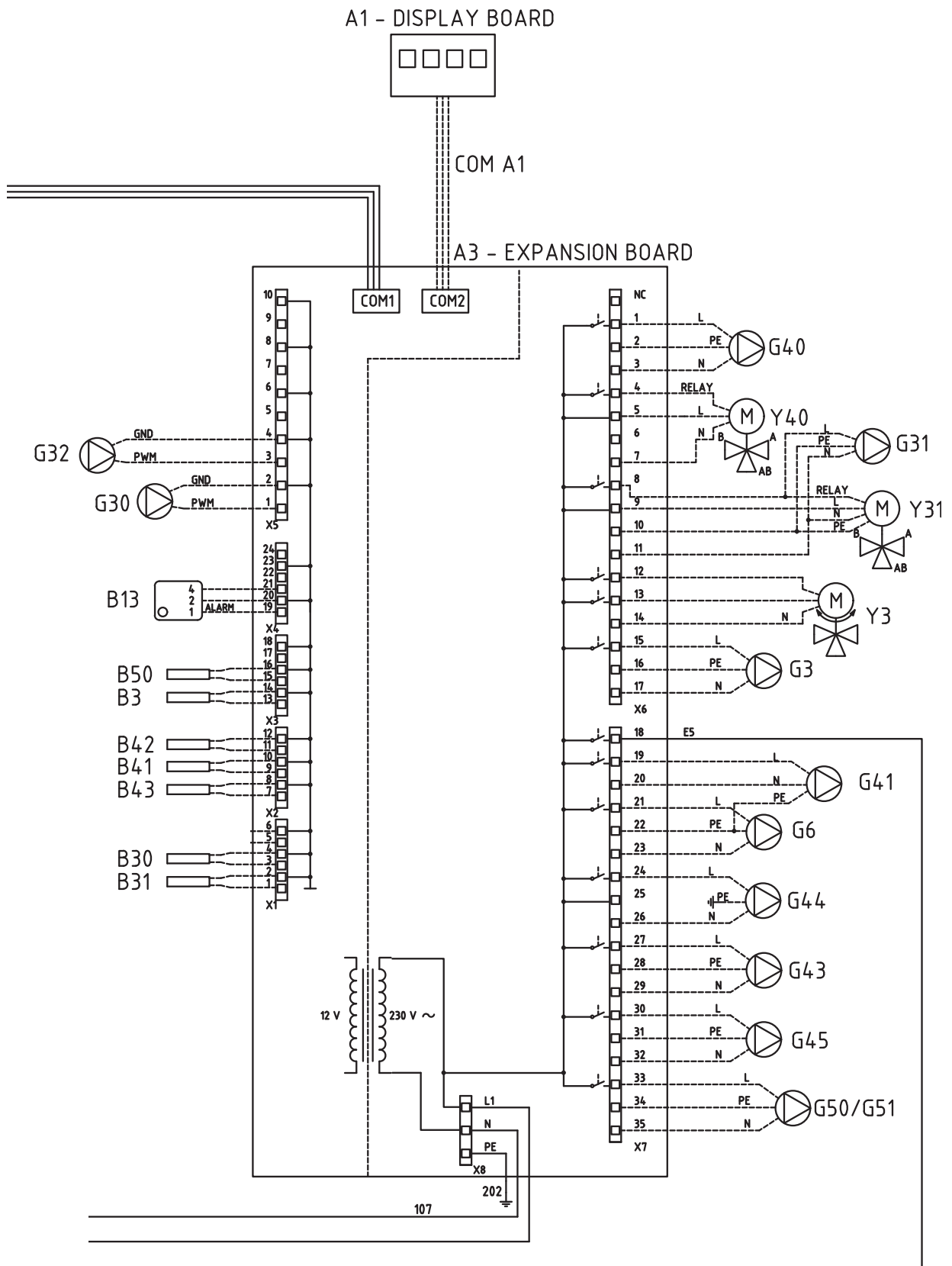

23.5 Parts list, Wiring diagram

A1	Display	
A2	Relay/main board	
A3	Expansion board	
B1	Primary flow sensor 1	NTC 22
B2	Primary flow sensor 2	NTC 22
B3	Primary flow sensor 3	NTC 22
B5	Temp Upper tank sensor	NTC 22
B6	Temp Lower tank sensor	NTC 22
B7	Return sensor	NTC 22
B8	Flue gas sensor	NTC 3.3
B9	Sensor wood boiler	NTC 22
B11	Room sensor 1	NTC 22
B12	Room sensor 2	NTC 22
B13	Room sensor 3	NTC 22
B15	Outdoor sensor	NTC 150
B17	Sensor external boiler	NTC 22
B30	Solar panel sensor In	PT 1000
B31	Solar panel sensor Out	PT 1000
B33	Temp solar coil tank	NTC 22
B41	Sensor, external buffer tank upper	NTC 22
B42	Sensor, external buffer tank lower	NTC 22
B43	Sensor external DHW tank	NTC 22
B50	Sensor pool	NTC 22
E11	Backup heating thermostat	
F1	Automatic circuit breaker	
F2	Automatic circuit breaker	
F10	Max thermostat	
G1	Radiator pump 1	
G2	Radiator pump 2	
G3	Radiator pump 3	
G6	Circulation pump flue gas controlled	
G11	Charge pump 1	
G12	Charge pump 2	
G13	Charge pump 3	

G30	Circulation pump, solar panel	
G31	Pump, bore hole recharging	
G32	Pump, plate heat exchanger – solar energy	
G40	Circulation pump for DHW circ.	
G41	Circulation pump external DHW tank	
G43	Circulation pump, external buffer tank charging	
G44	Circulation pump, external boiler	
G45	Circulation pump, external buffer tank discharging	
G50/G51	Circulation pump, pool heating	
K1	Contactor 1	
K2	Contactor 2	
K3	Contactor 3	
K4	Contactor 4	
K22	Flexible remote control/ SmartGrid	
K23	Flexible remote control/ SmartGrid	
K24	Flexible remote control/ SmartGrid	
K25	Flexible remote control/ SmartGrid	
X1	Terminal block	
X10	Terminal block	
Y1	Mixing valve 1	
Y2	Mixing valve 2	
Y3	Mixing valve 3	
Y21	3-way valve, heat pump in/out	
Y31	3-way valve solar	
Y40	3-way valve external buffer tank	
NC	Alarm output, External signal	NC
NO	Alarm output, External signal	NO
Alarm	Alarm output, External signal	C

23.6 Resistances for sensors

NTC 3.3K		NTC 22K		NTC 150	
Temperature °C	Flue gas sensor Resistance Ω	Temperature °C	Electric boiler, Primary flow, Room sensor Resistance Ω	Temperature °C	Outdoor sensor Resistance Ω
300	64	130	800	70	32
290	74	125	906	65	37
280	85	120	1027	60	43
270	98	115	1167	55	51
260	113	110	1330	50	60
250	132	105	1522	45	72
240	168	100	1746	40	85
230	183	95	2010	35	102
220	217	90	2320	30	123
210	259	85	2690	25	150
200	312	80	3130	20	182
190	379	75	3650	15	224
180	463	70	4280	10	276
170	571	65	5045	5	342
160	710	60	5960	0	428
150	892	55	7080	-5	538
140	1132	50	8450	-10	681
130	1452	45	10130	-15	868
120	1885	40	12200	-20	1115
110	2477	35	14770	-25	1443
100	3300	30	18000	-30	1883
90	4459	25	22000	-35	2478
80	6119	20	27100	-40	3289
70	8741	15	33540		
60	12140	10	41800		
50	17598	5	52400		
40	26064				
30	39517				
20	61465				

PT1000

Temperature °C	Resistance Ω	Temperature °C	Resistance Ω
-10	960	60	1232
0	1000	70	1271
10	1039	80	1309
20	1077	90	1347
30	1116	100	1385
40	1155	120	1461
50	1194	140	1535

24. Installation, Communication

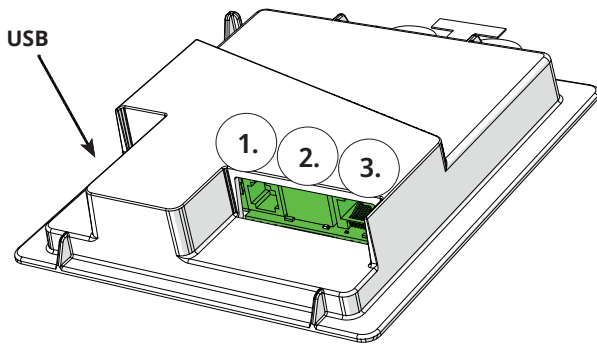

The back of the display unit has 3 communication ports.

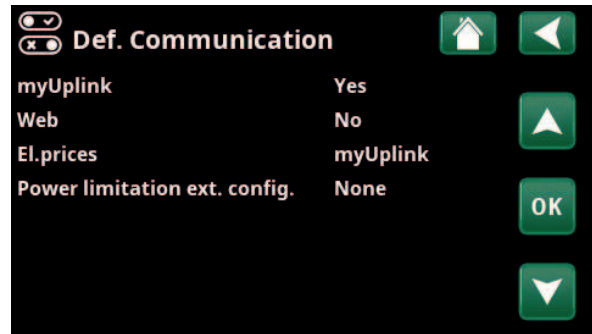

Menu: "Advanced/Define/Communication".



Display communication ports

- 1 **Port 1. RS485 port without galvanic protection.**
 Define BMS:
 "Yes" permits BMS via the RS485 port.

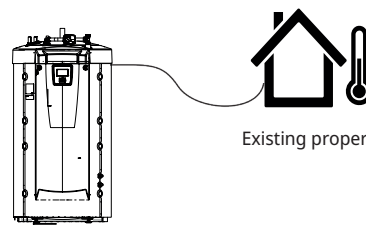

CTC Product

Description of connection in display unit

- 1: Earth
- 4: RS485 B
- 5: RS485 A

- 2 **Port 2. Network jack (ethernet), see connection information on following page.**
 Define the app:
 myUplink: "Yes" enables connection to the app.

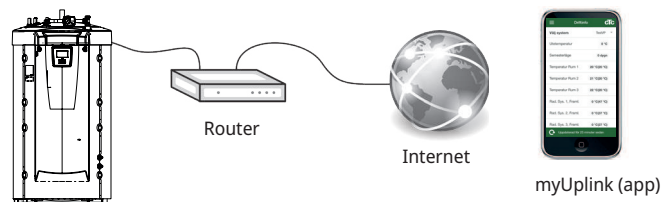

CTC Product

- Define Web:
 "Yes" permits network connection, the "CTC Remote" screen mirror feature and BMS* function with remote control via network cable to local network.

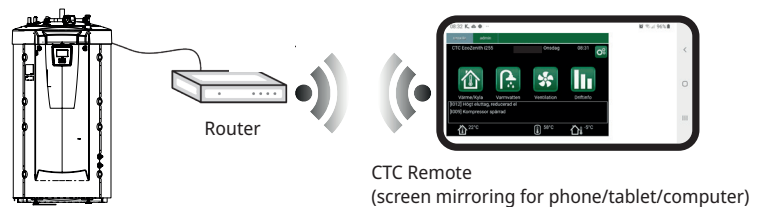

CTC Product

CTC Remote (screen mirroring for phone/tablet/computer)

- 3 **Port 3. Communication between the product's electrical cabling and display: Factory fitted.**

*Port 2 - Network socket (Ethernet) when connecting the BMS via TCP/IP.

24.1 Fitting the ethernet cable

In order to define and enable connection to the network and app, an ethernet cable must be connected as described below.

1. Route the ethernet cable on the left side of the product in the space between the side insulation and the top insulation. The plastic top cover then needs to be unscrewed and carefully lifted up enough to be able to ease the cable in, see illustration.
2. Open the ferrite from the packaging, clamp around the ethernet cable with the connector.
3. Connect the ethernet cable to the display.
4. Connect ethernet cable to network port or router.

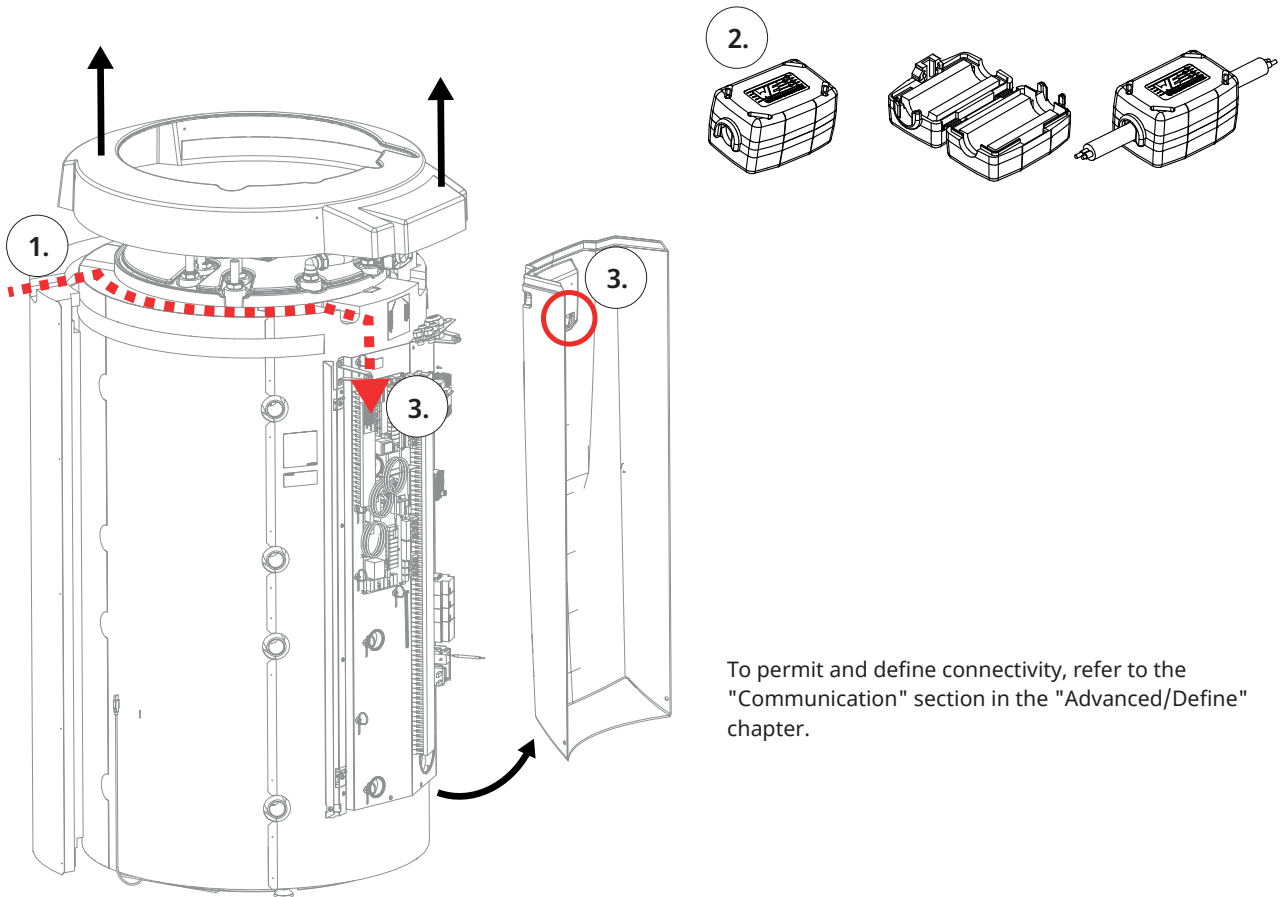

To permit and define connectivity, refer to the "Communication" section in the "Advanced/Define" chapter.





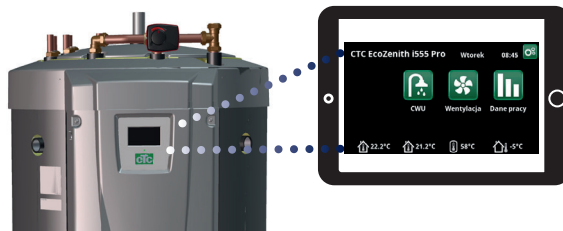

24.2 Remote - Screen Mirroring

- Connect the ethernet cable, see previous page.
- Advanced/Define/Communication/Web – Yes. Permits the product to connect with unencrypted web traffic on local area networks. Internet router and firewall required.
- Advanced/i – Scan the QR code with a tablet or smartphone. 
- Save as a favourite/icon on your mobile phone/tablet/computer. When your mobile phone/tablet is connected to the local network, the touch screen on the product can be accessed just as if you were using the product's display.
- In the app: scan QR code or enter address "http://ctcXXXX/main.htm". (XXXX = the last four digits of the display serial number, for example S/N 888800000040 = "http://ctc0040/main.htm"). In case of problems: click the link to update to the device's current IP no.



Tablet/Smartphone/PC as a touchscreen for local area network "Advanced/Define/Communication/Web" – "Yes".

 **System information**
 

Serial number	888800000040
MAC address	020000000025
Program version	20200422
Bootloader version	1.0
Legal information	
http://ctc0040/main.htm	

24.3 myUplink



With myUplink you can conveniently monitor and change the settings of your heat pump and your heating system from your mobile phone. Change the desired indoor temperature, hot water settings or activate the vacation mode remotely via myUplink. The app shows easy-to-understand graphics in which you can follow the temperatures and the performance of the heat pump. myUplink also receives push notifications when your heat pump alarms.

App installation

- Download myUplink from AppStore or Google Play.
- Create an account.
- Add system.

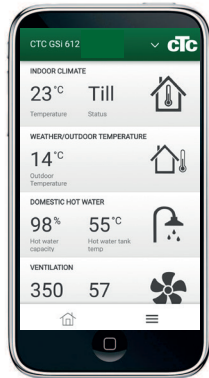

Define myUplink

Define myUplink in the display menu "Advanced/Define/Communication".

myUplink

No (Yes/No)

Select "Yes" to connect the main product to the myUplink app.

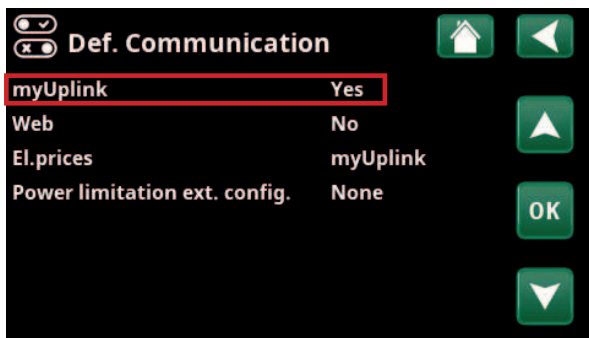

Connect myUplink

The display menu "Advanced/Settings/Communication/myUplink" has lines highlighted in grey until the display is connected to myUplink.

When the connection is established, the top line "Get connection string" lights up.

When the time has expired, the connection string disappears from the display and you can request a new string by pressing "Get connection string" in the display.

Connect the system to the myUplink app by scanning the QR code in the display menu, or enter the connection information manually. See section "Add System".



Add System

Connect your system to your account by clicking the down arrow next to the logo in the upper right corner of the myUplink app. Then select "Add System" *.

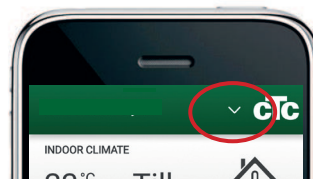

Scan QR code

Select "Scan the QR code" and then scan the QR code in the display (Advanced/Settings/Communication/myUplink). Check the data generated and press "Add".

Enter manually

If the QR code is missing or if the QR code can not be read; first press "Enter manually" and then "Enter connection details".

- Enter the serial number and connection string and press "Continue".
- Enter the name of the system (eg property address).
- Enter the postal code where the system is located.
- Select the country where the system is located.

Add user

First, to create an account, the app must be downloaded and an account created before the user can be added.

Multiple users can be connected to the same system. As an administrator, you can add users so that they can monitor your system. Only existing accounts can be added. These are categorised according to the permissions "Monitor" and "Control".

i The website <https://myuplink.com> can also be used to control and monitor the system.

*To establish a new connection, previous users must be deleted.

25. First start

CTC EcoZenith i555 can be started without a room sensor being installed; the heating will instead be controlled by the heat curve set for the property. The room sensor can however always be fitted for the alarm LED function. In this case, deselect the room sensor in the "Advanced/Define" menu.

25.1 Before first start

1. Check that the system is filled with water, has been bled and has the correct pressure, and that there are no leaks. Air in the system (poor circulation) can mean that the heat pump is tripped by its high pressure protection, for example.
2. Check that all connections are tight.
3. Check that all the valves in the system are correctly connected and set.
4. Check that all electric cables, sensors and circulation pumps are correctly installed and connected. See the "Electrical installation" chapter.
5. Check that the unit is correctly fused (fuse panel).
6. The backup heating thermostat has OFF as its factory setting. Recommended mode is ❄️= Frost protection setting, approx. +7 °C. The backup heating thermostat is located in the electrical switchboard behind the front panel. It is in the OFF position when it is turned anticlockwise as far as it will go (the screwdriver slot should be horizontal).

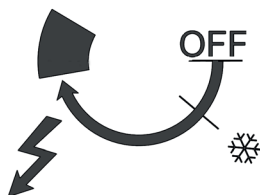

7. Check that any heat pump circuit breaker installed is in the ON position. Note that the last heat pump in a series connection must be in the terminated position, i.e. DIP switch 2 on the last heat pump must be in the ON position and the other heat pumps in the OFF position.
8. See the Installation and Maintenance Manual for the heat pump. If there is already a boiler in place, check that its temperature is set at normal boiler temperature, for example, 70°C.

25.2 First start

Switch on the power using the safety switch. The display will come on and the operating lamp will start to light up. Factory-set values will apply, so for instance, the connected heat pumps' compressors are blocked. The first time the CTC EcoZenith is started up or if it is restarted within 24 hours after start-up, items 1–3 are displayed.

9. Select desired language and confirm with OK -> Next.

10. Verify that the system is filled with water Confirm with -> Next.
11. Input voltage; select desired input voltage. Confirm with -> Next.
12. Main fuse A; select size of main fuse (10–90 A). Confirm with -> Next.
13. Conversion factor for current sensor; select desired factor (1–10). This menu contains the factor the current sensor is to use. This setting is only performed if the connection has been installed for a current sensor for higher currents. Example: User (set) value 2 => 16 A will be 32 A. Confirm with -> Next.
14. Max power immersion heaters kW, select between 0 and 27.0 kW.
15. Compressor 1, confirm whether compressor 1 is to be blocked or permitted. This can also be changed in the Advanced/Settings/Heat Pump 1-3 menu. Confirm with -> Next.
16. Set the Max primary flow °C, Inclination and Adjustment for each heating circuit. See also the menu: Advanced/Settings/Heating circuit 1-3. Confirm with -> Next.
17. The CTC EcoZenith is now up and running and the product is working using its factory settings. For other settings, refer to the "Detailed Menu Descriptions" chapter.

i Save these settings in the "Advanced/Settings/Save Settings" menu.

25.2.1 Getting started

Define system

- The CTC EcoZenith senses whether primary flow sensors 1 and 2 and room sensors 1 and 2 are connected and if so, automatically defines heating circuits 1 and 2 "Yes" with the associated room sensor "Yes".
- Scroll further down in the menu and select the connected systems with "Yes". The immersion heaters are factory set to "Yes".
- For heat pump operation, the pumps in question are defined 1–3 by selecting "Yes". For the relevant heat pump, the type of heat pump must then be selected, CTC EcoPart or CTC EcoAir, followed finally by selection of relay-controlled or speed-controlled (PWM) charge pump.

Operation data

- Check whether heat is needed in the upper and lower tank Heat is needed when the temperature in the upper or lower tank is 5°C below the setpoint in brackets. When this occurs, start-up of the compressor should be delayed 10 minutes. Information on this is available in the main menu. Return to the main menu to check.



CTC AB
Box 309 SE-341 26 Ljungby
+46 372 88 000
info@ctc.se
www.ctc.se